



TI-P133-100
ST Issue 1

M40SiJ ISO and M40ViJ ISO Jacketed Reduced Bore Ball Valves DN40 to DN100 Flanged ASME 150

Description

The M40_iJ ISO are jacketed reduced bore ball valves, having a single piece body and ISO mounting as standard. They have been designed for applications that use heating fluid to maintain the product viscosity passing through the ball valve (e.g. chocolate, tar, fat and others). These valves are isolating valves, not control valves.

Available types

M40SiJ2 ISO	Carbon steel body, PDR 0.8 seats.
M40SiJ3 ISO	Stainless steel body, PDR 0.8 seats.
M40ViJ2 ISO	Carbon steel body, PTFE seats.
M40ViJ3 ISO	Stainless steel body, PTFE seats.

Standards - These products fully comply with the requirements of the European Pressure Equipment Directive 97/23/EC and carry the **CE** mark when so required.

Certification - These products are available with certification to EN 10204 3.1. **Note:** All certification/inspection requirements must be stated at the time of order placement.

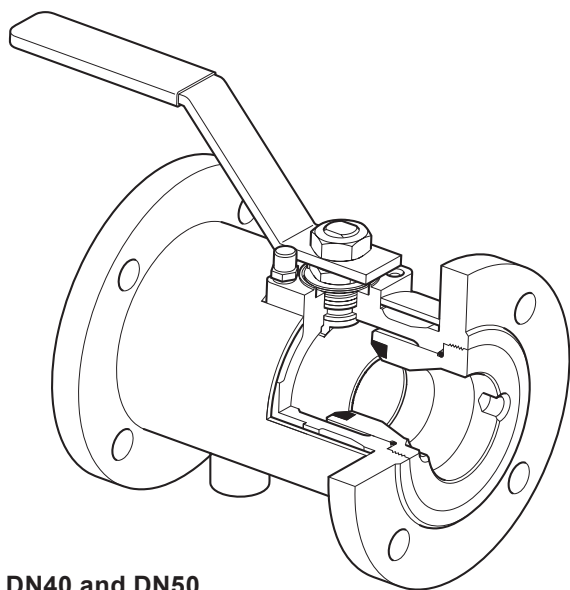

DN40 and DN50

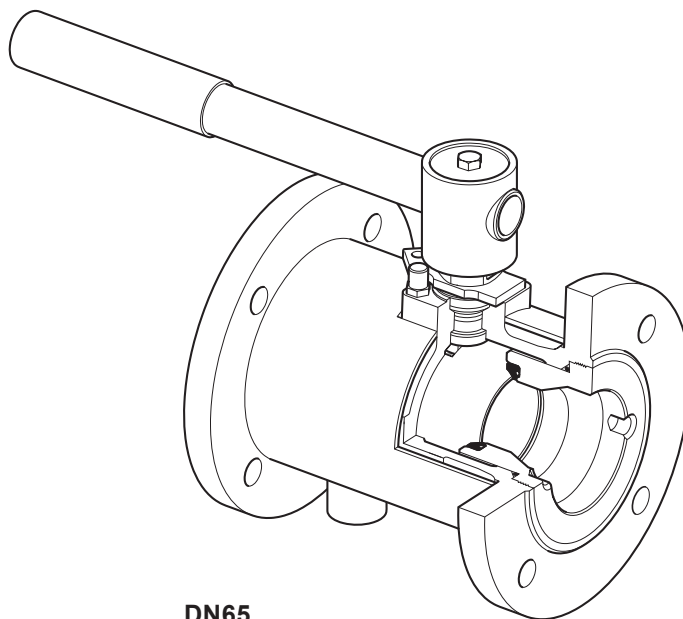

DN65

Sizes and pipe connections

DN40, DN50, DN65, DN80 and DN100

Standard flange: ASME 150 with face-to-face dimensions according to ASME 16.10

Jacket input and output connections: Threaded 1/2" BSPT

Technical data

Flow characteristic	Modified linear
Port	Reduced bore
Leakage test procedure to ISO 5208 (Rate A)/EN 12266-1 (Rate A)	
Antistatic device (optional) complies with ISO 7121 and BS 5351	

Pressure / temperature limits

M40SiJ - PDR 0.8 seats

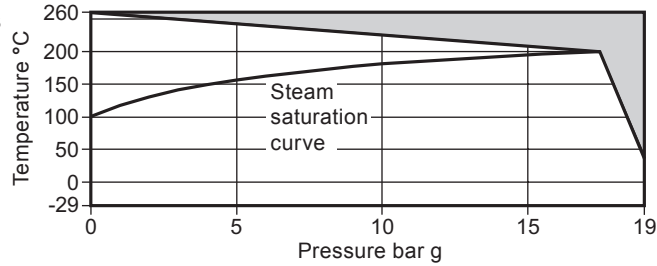

M40ViJ - PTFE seats

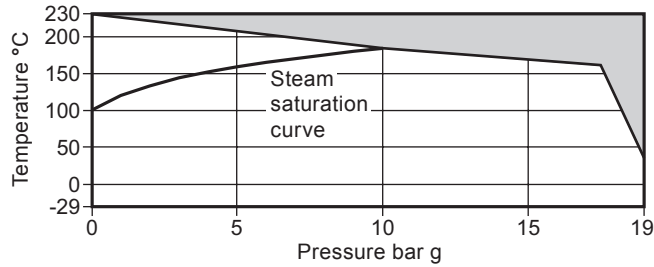

The product **must not** be used in this region.

Body design conditions		ASME 150
PMA	Maximum allowable pressure	19 bar g @ 38°C
TMA	Maximum allowable temperature	M40SiJ 260°C @ 0 bar g
		M40ViJ 230°C @ 0 bar g
PMO	Maximum operating pressure for saturated steam service	M40SiJ 17.5 bar g
		M40ViJ 10 bar g
PMO	Jacket	10 bar g
TMO	Maximum operating temperature	M40SiJ 260°C @ 0 bar g
		M40ViJ 230°C @ 0 bar g
Δ PMX Maximum differential pressure is limited to the PMO		
Designed for a maximum cold hydraulic test pressure of:	Valve	28.5 bar g
	Jacket	15 bar g

Materials

No.	Part	Material	
1a	Body	M40SiJ2 ISO and M40ViJ2 ISO	Carbon steel ASTM A216 WCB
		M40SiJ3 ISO and M40ViJ3 ISO	Stainless steel ASTM A351 CF8M
1b	Jacket	M40SiJ2 ISO and M40ViJ2 ISO	Carbon steel SAE 1010 / SAE 1020
		M40SiJ3 ISO and M40ViJ3 ISO	Stainless steel AISI 304
2	Insert	M40SiJ2 ISO and M40ViJ2 ISO	Carbon steel SAE 1040
		M40SiJ3 ISO and M40ViJ3 ISO	Stainless steel AISI 316
3	Ball	Stainless steel	AISI 316
4	Stem	Stainless steel	AISI 316
5	Seats	M40SiJ2 ISO and M40SiJ3 ISO	Carbon and graphite reinforced PTFE PDR 0.8
		M40ViJ2 ISO and M40ViJ3 ISO	Virgin PTFE
6	Insert 'O' ring	EPDM	Geothermal
9	Stem seal	Antistatic R-PTFE	
10	Stem seal	Stainless steel	AISI 304
13	Separator	Zinc plated carbon steel	SAE 1010
14	Belleville washer	Stainless steel	AISI 301
15	Gland nut	Zinc plated carbon steel	SAE 1010/SAE 12L14
16	Upper stem nut	Zinc plated carbon steel	SAE 1010/SAE 12L14
17	Locking plate	Stainless steel	AISI 304
18	Nameplate	Stainless steel	AISI 430
20	Lever	Zinc plated carbon steel	SAE 1010
21	Grip	Vinyl	
25	Stop screw	Zinc plated carbon steel	SAE 12L14

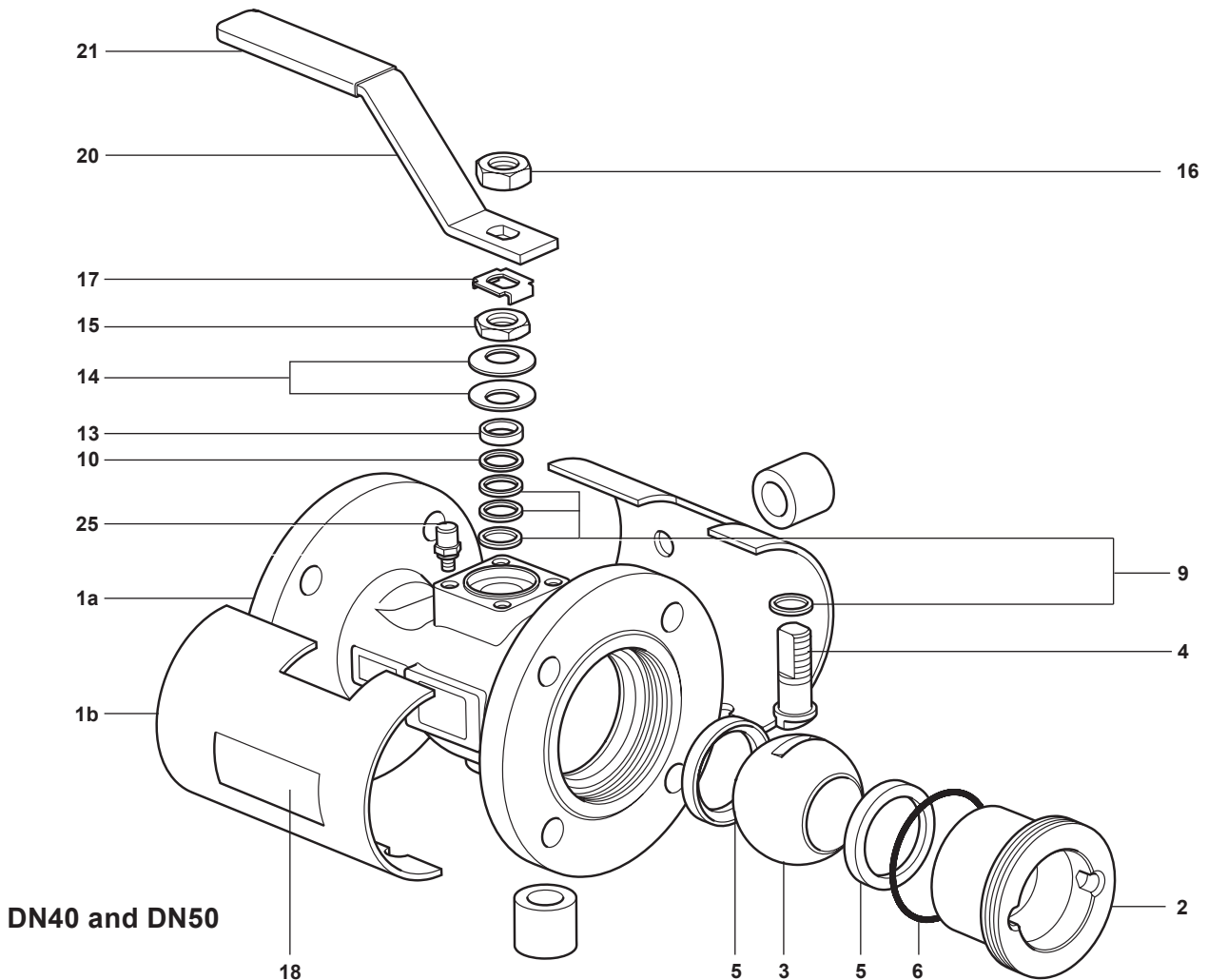

Materials (parts 1 - 14)

No.	Part	Material	
1a	Body	M21SiJ2 ISO and M21ViJ2 ISO	Carbon steel ASTM A216 WCB
		M21SiJ3 ISO and M21ViJ3 ISO	Stainless steel ASTM A351 CF8M
1b	Jacket	M21SiJ2 ISO and M21ViJ2 ISO	Carbon steel SAE 1010 / SAE 1020
		M21SiJ3 ISO and M21ViJ3 ISO	Stainless steel AISI 304
2	Insert	M21SiJ2 ISO and M21ViJ2 ISO	Carbon steel SAE 1040
		M21SiJ3 ISO and M21ViJ3 ISO	Stainless steel AISI 316
3	Ball	Stainless steel	AISI 316
4	Stem	Stainless steel	AISI 316/AISI 420
5	Seat	M21SiJ2 ISO and M21SiJ3 ISO	Carbon and graphite reinforced PTFE PDR 0.8
		M21ViJ2 ISO and M21ViJ3 ISO	Virgin PTFE
6	Insert 'O' ring	EPDM	Geothermal
7	Seat 'O' ring	EPDM	Geothermal
8	Stem 'O' ring	EPDM	Geothermal
11	Lower stem seals	Antistatic R-PTFE	
12	Upper stem packing	Virgin PTFE	
13	Separator	Zinc plated carbon steel	SAE 1010
14	Belleville washer	Stainless steel	AISI 301

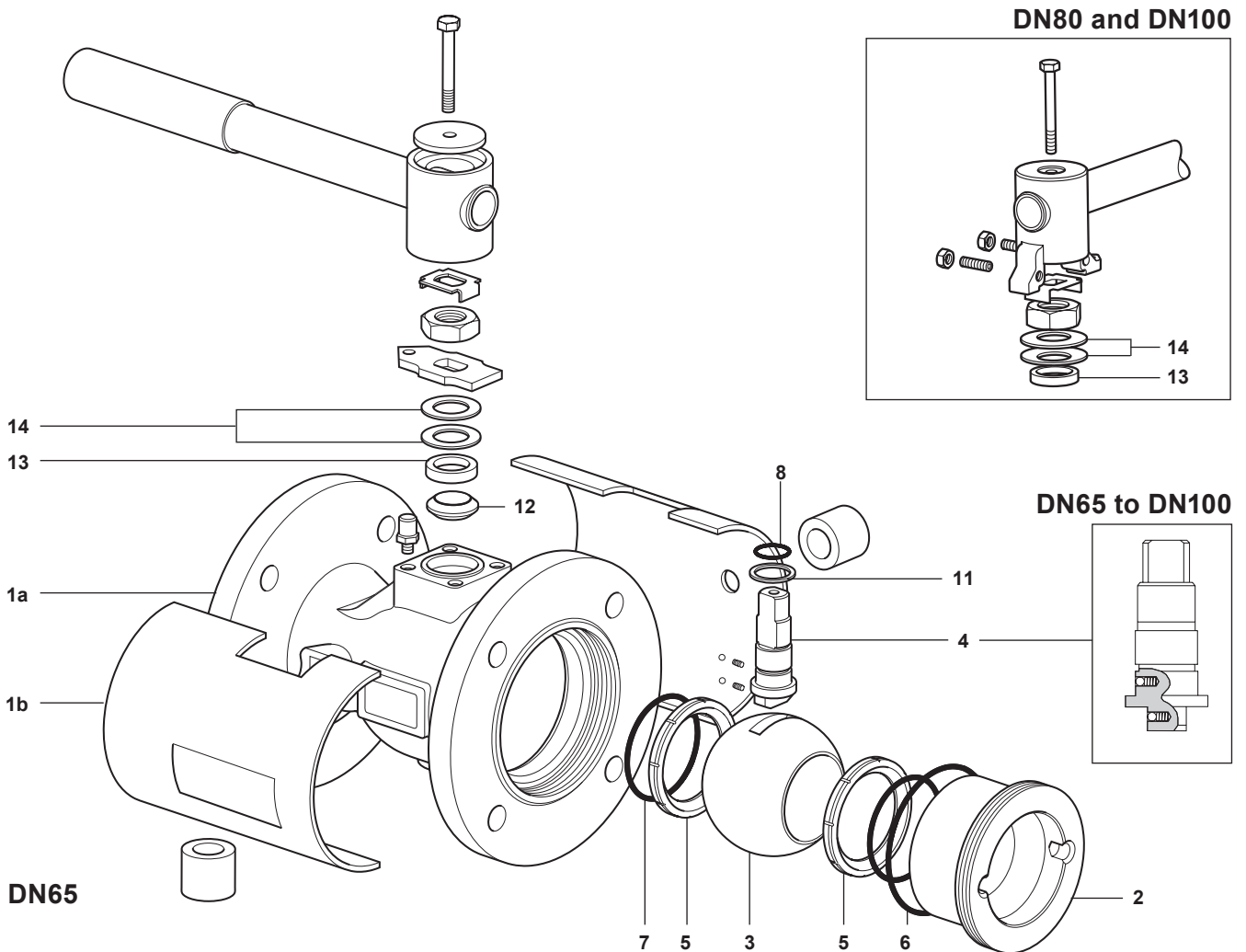

Materials (parts 15 - 32)

No.	Part	Material	
15	Gland nut	Zinc plated carbon steel	SAE 1010/SAE 12L14
17	Locking plate	Stainless steel	AISI 304
18	Nameplate	Stainless steel	AISI 430
19	Stop plate with indicator DN65 only	Zinc plated carbon steel	SAE 1010
20	Lever	Zinc plated carbon steel	SAE 1010
21	Grip	Vinyl	
22	Adaptor DN65 only	Zinc plated SG iron	
23	Adaptor plate DN65 only	Zinc plated carbon steel	SAE 1010
24	Adaptor with indicator DN80 and DN100	Zinc plated SG iron	
25	Stop screw DN80 and DN100	Zinc plated carbon steel	SAE 12L14
27	Adaptor screw	Zinc plated carbon steel	Grade 5
28	Stop screw	Carbon steel	
29	Adaptor hex. nut DN80 and DN100	Zinc plated carbon steel	
31	Antistatic device ball	Stainless steel	AISI 302
32	Antistatic device spring	Stainless steel	AISI 301

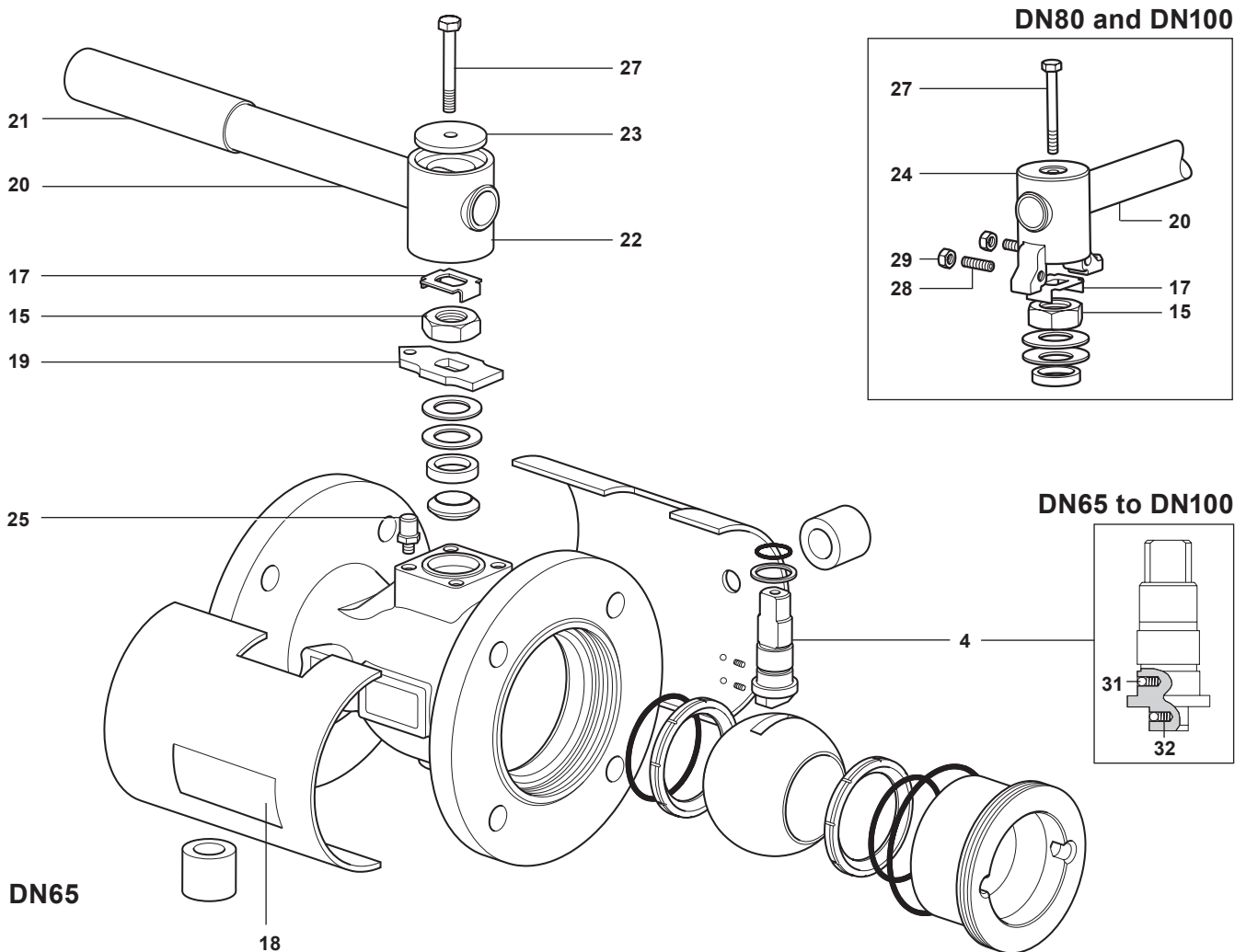

Dimensions/weights (approximate) in mm and kg
Flanged ASME 150

Size	A	B	C	D	E	F	Weight
DN40	165	70	186	127	118	30	5.6
DN50	178	75	186	152	123	37	8.1
DN65	190	79	278	178	144	50	12.3
DN80	203	91	417	191	157	57	16.0
DN100	229	98	517	229	172	75	25.2

Flange connections

Size	Number of flange holes	Hole thread size
DN40	4	½" NC
DN50	4	⅝" NC
DN65	4	⅝" NC
DN80	4	⅝" NC
DN100	8	⅝" NC

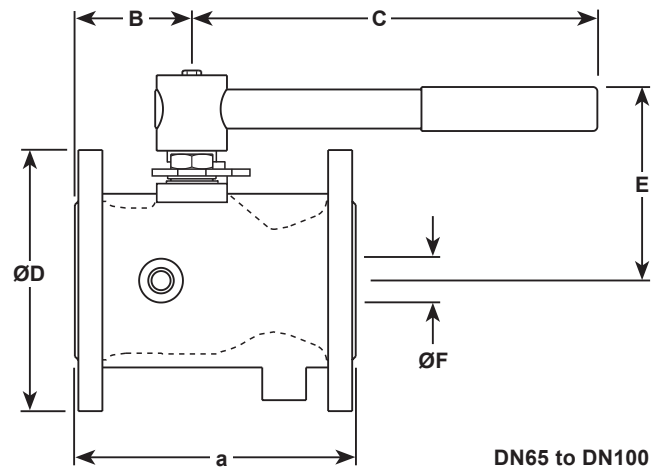
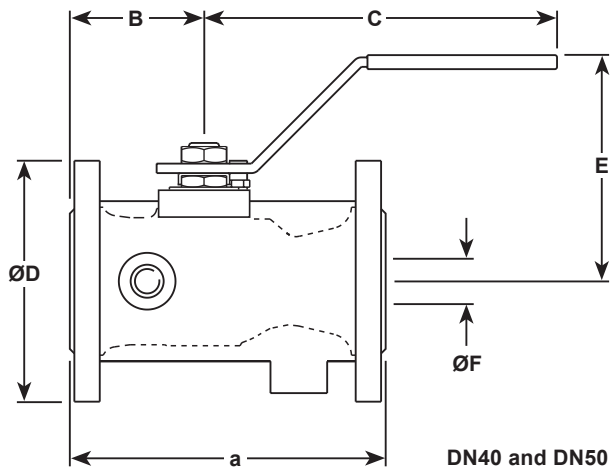

K_V values

DN	40	50	65	80	100
K _V	81	103	197	248	581

For conversion C_V (UK) = $K_V \times 0.963$ C_V (US) = $K_V \times 1.156$

Operating torque (N m)

DN	40	50	65	80	100
N m	20	25	50	70	100

Note: The torque figures shown are for a valve that is frequently operated at the maximum operating pressure. Valves that are subject to long static periods, may require a greater break-out torque.

Safety information, installation and maintenance

For full details see the Installation and Maintenance Instructions supplied with the product.

Welding

Only the models that have connections designed for welding (SW, BW, Imperial Tube connections) should be welded. Valves with flanged connections must not be welded to avoid damages to the soft parts.

How to order

Specify	Model	Seat material	Si = Carbon and graphite reinforced PTFE - PDR 0.8
			Vi = Virgin PTFE
	Body type		J = Jacketed body
Material		Body material	2 = Carbon steel
			3 = Stainless steel

Example: 1 off Spirax Sarco DN50 M40ViJ2 ISO ball valve having flanged ASME 150 connections.

Optional extras:

- Self-venting ball.
- Extended stems to allow full insulation: 50 mm (2") for DN40 and DN50 sizes and 100 mm (4") for DN40 to DN100 sizes.
- Lockable handle.
- 100 mm extended stem with lockable handle.

DN40 and DN50 - Spare parts (see page 8 for sizes DN65 - DN100)

The spare parts available are shown in solid outline. Parts drawn in a grey line are not supplied as spares.

Available spares

Seats, insert 'O' ring and stem seals

5, 6, 9, 10

How to order spares

Always order spares by using the description given in the column headed 'Available spares' and state the size and type of ball valve.

Example: 1 set of seats, insert 'O' ring and stem seals for a Spirax Sarco DN50 flanged ASME 150 M40SiJ2 ball valve.

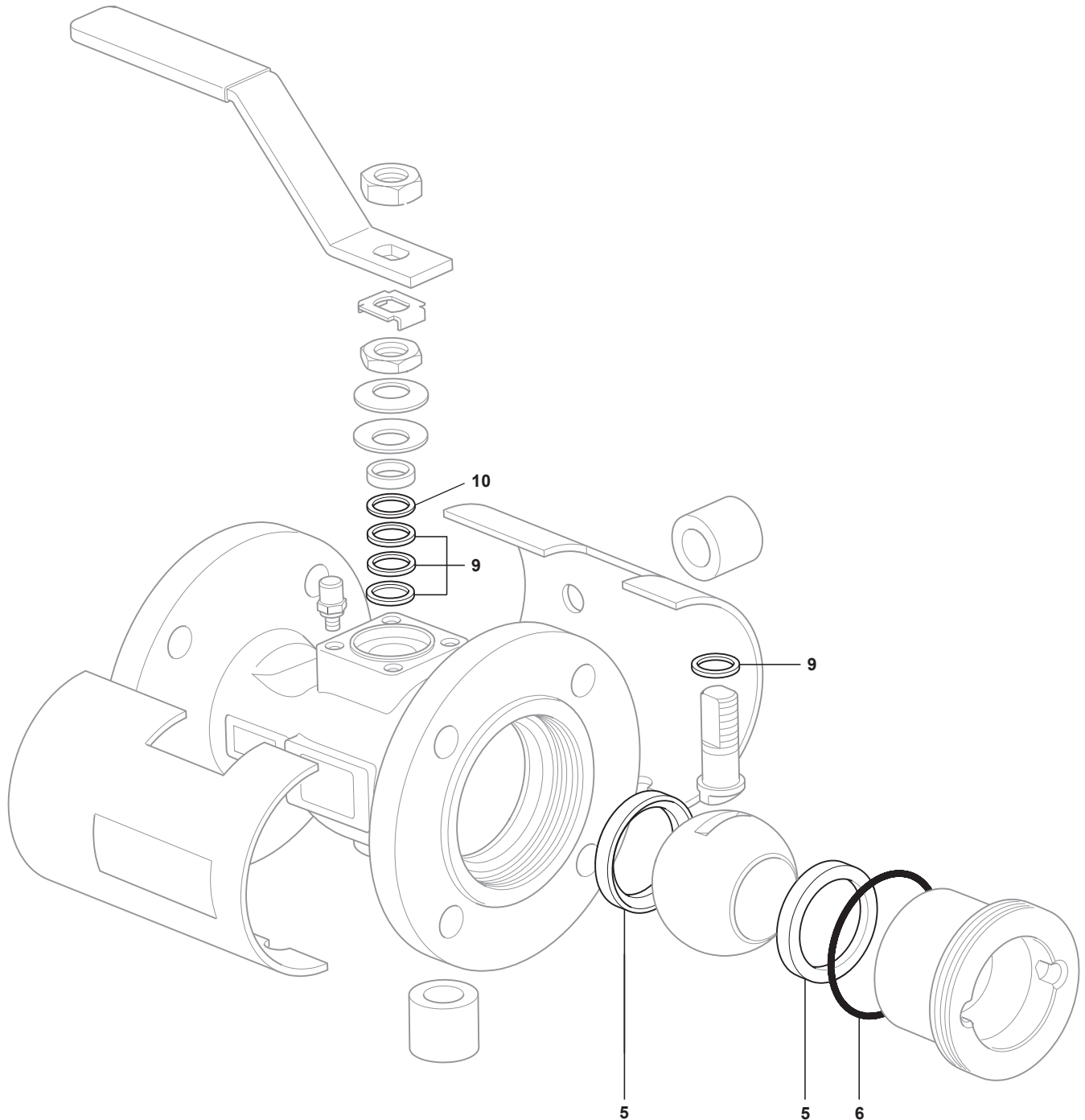

DN40 and DN50

DN65 to DN100 - Spare parts (see page 7 for sizes DN40 and DN50)

The spare parts available are shown in solid outline. Parts drawn in grey line are not supplied as spares.

Available spares

Seats, insert 'O' ring, seat 'O' rings, stem 'O' ring, lower stem seals and upper stem packing

5, 6, 7, 8, 11, 12

How to order spares

Always order spares by using the description given in the column headed 'Available spares' and state the size and type of ball valve.

Example: 1 set of seats, insert 'O' ring, seat 'O' rings, stem 'O' ring, lower stem seals and upper stem packing for a Spirax Sarco DN80 flanged ASME 150 M40SiJ2 ball valve.

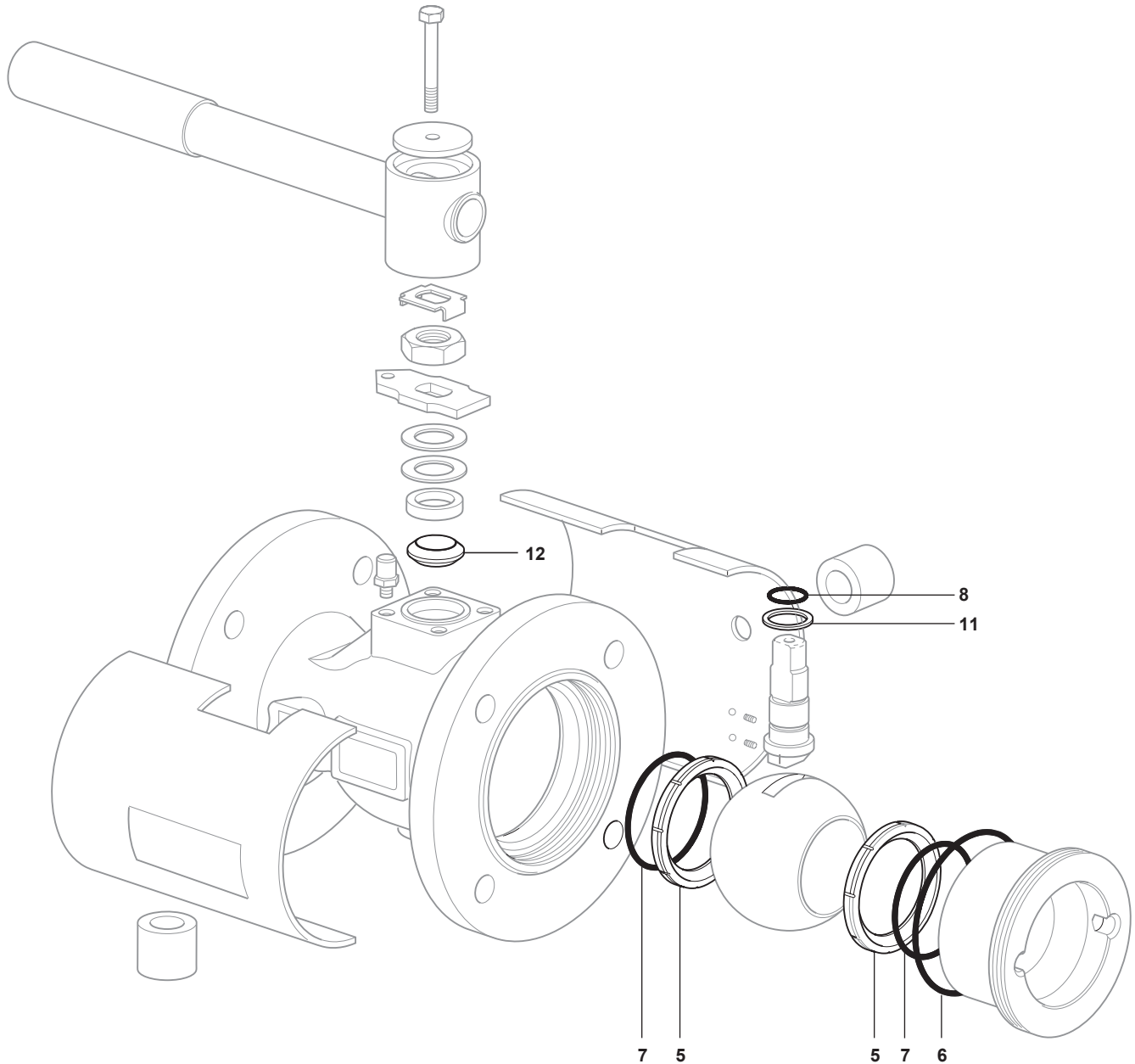

DN65 to DN100