



M31V ISO Full Bore Ball Valve DN50 to DN200 DIN PN16 (F1 and F4)

Description

The M31V ISO full bore two-piece body ball valve, has been designed for use as an isolating valve, not a control valve. It can be used with the majority of industrial fluids on applications, which include steam, condensate, water, oil and other fluids within its operating range. It is not recommended for gases applications. The M31V ISO DIN has antistatic seats as standard and an ISO mounting pad in accordance with ISO 5211.

DN50 shown

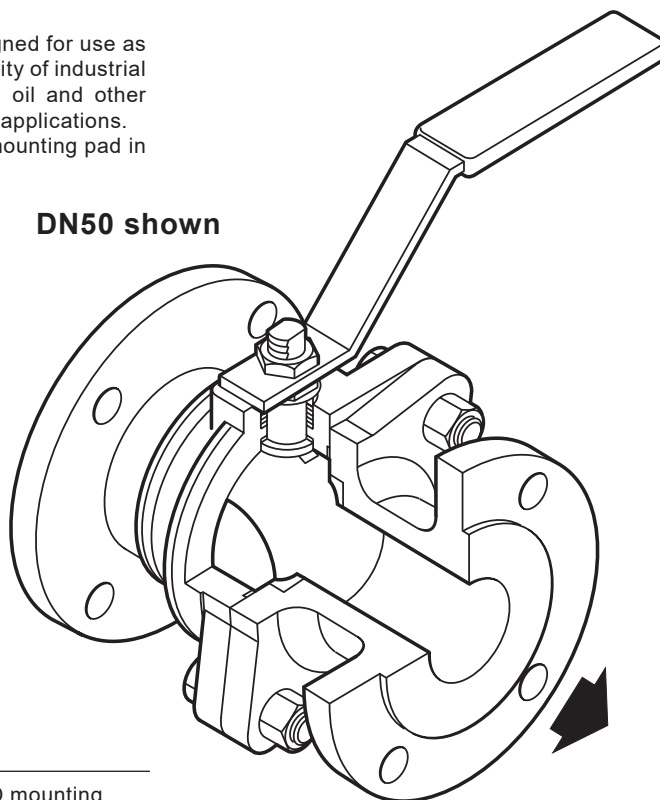

Available types

M31V2 ISO Zinc plated carbon steel body, PTFE seats and ISO mounting.

M31V3 ISO Stainless steel body, PTFE seats and ISO mounting.

Standards

This product fully complies with the requirements of the Pressure Equipment Directive (PED) and carries the  mark when so required.

Certification

This product is available with certification to EN 10204 3.1.

Note: All certification/inspection requirements must be stated at the time of order placement.

Options

- Self-venting ball.
- Operation by manual handwheel for bigger sizes (DN100 to 200).
- Operation by pneumatic actuator BVA200 series for all sizes.
- Other ball materials are available on request (i.e: 11-13% Cr).

Sizes and pipe connections

DN50, DN65, DN80, DN100, DN150 and DN200.

Standard flange EN 1092 PN16 with face-to-face dimensions according to DIN 3202 F1 and F4/F5.

Technical data

Flow characteristic	Modified linear
Port	Full bore
Leakage test procedure to ISO 5208 (Rate A)/EN 12266-1 (Rate A)	
Antistatic device	Complies with ISO 7121

Pressure/temperature limits

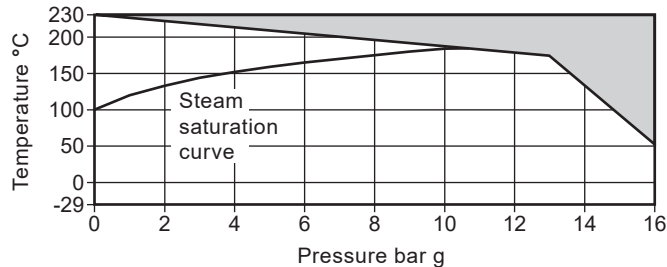

The product **must not** be used in this region.

Body design conditions	BS 5351
PMA Maximum allowable pressure	16 bar g @ 50 °C
TMA Maximum allowable temperature	230 °C @ 0 bar g
Minimum allowable temperature	-29 °C
PMO Maximum operating pressure for saturated steam service	10 bar g
TMO Maximum operating temperature	230 °C @ 0 bar g
Minimum operating temperature	-29 °C
Note: For lower operating temperatures consult Spirax Sarco.	
ΔPMX Maximum differential pressure is limited to the PMO	
Designed for a maximum cold hydraulic test pressure of:	24 bar g

Materials

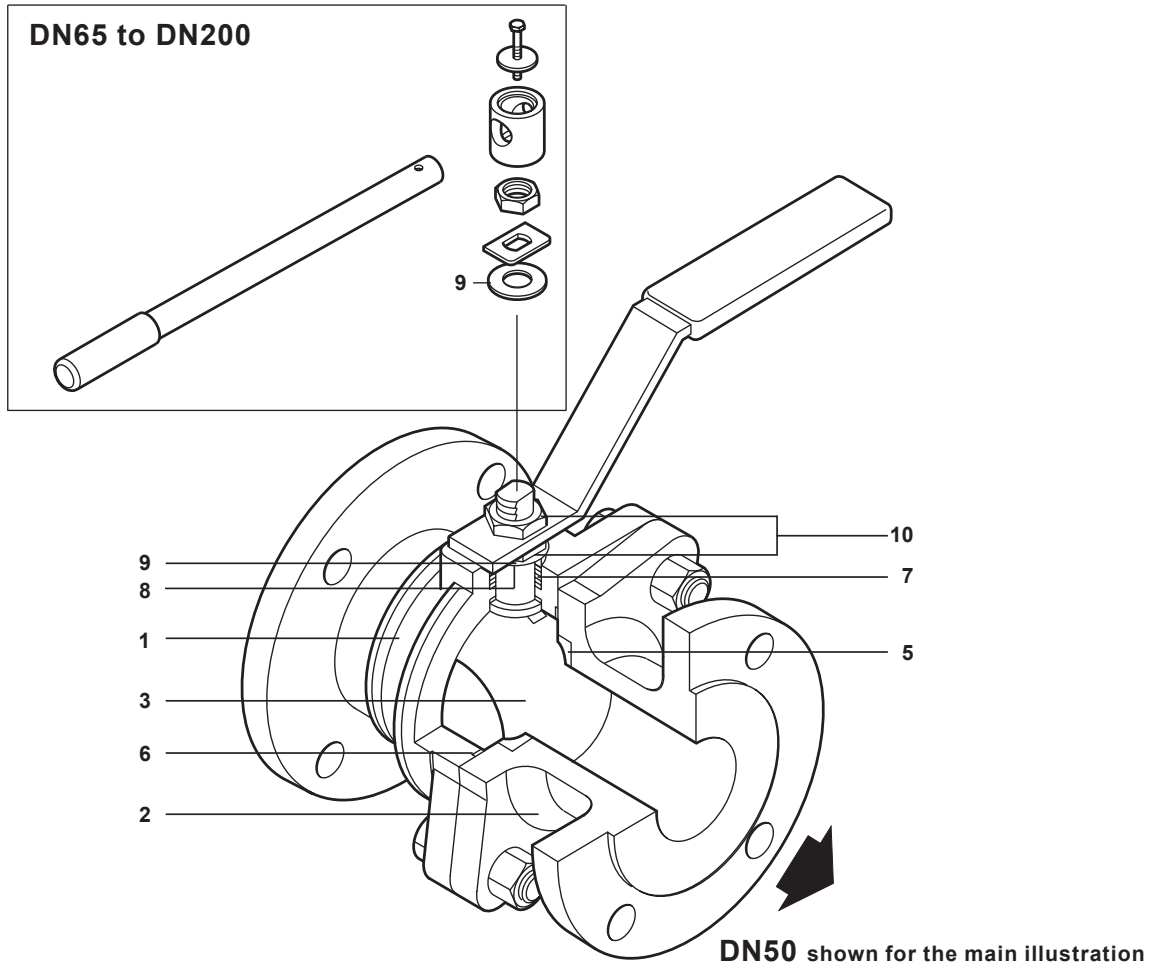

No.	Part	Material		
1	Body	M31V2 ISO	Zinc plated carbon steel	ASTM A216 WCB
		M31V3 ISO	Stainless steel	ASTM A 351 CF8M
2	Insert	M31V2 ISO	Zinc plated carbon steel	ASTM A216 WCB
		M31V3 ISO	Stainless steel	ASTM A 351 CF8M
3	Ball	Stainless steel	AISI 316	
4	Stem	Stainless steel	AISI 316/AISI 420	
5	Seats	PTFE		
6	Body gasket	Graphoil		
7	Stem seals	PTFE		
8	Separator	Zinc plated carbon steel	SAE 1010	
9	Belleville washer	Stainless steel	AISI 316	
		Carbon steel (DN150 and DN200)		
10	Nut	Zinc plated carbon steel	SAE 12L14	

Materials continued on page 4

Materials (continued)

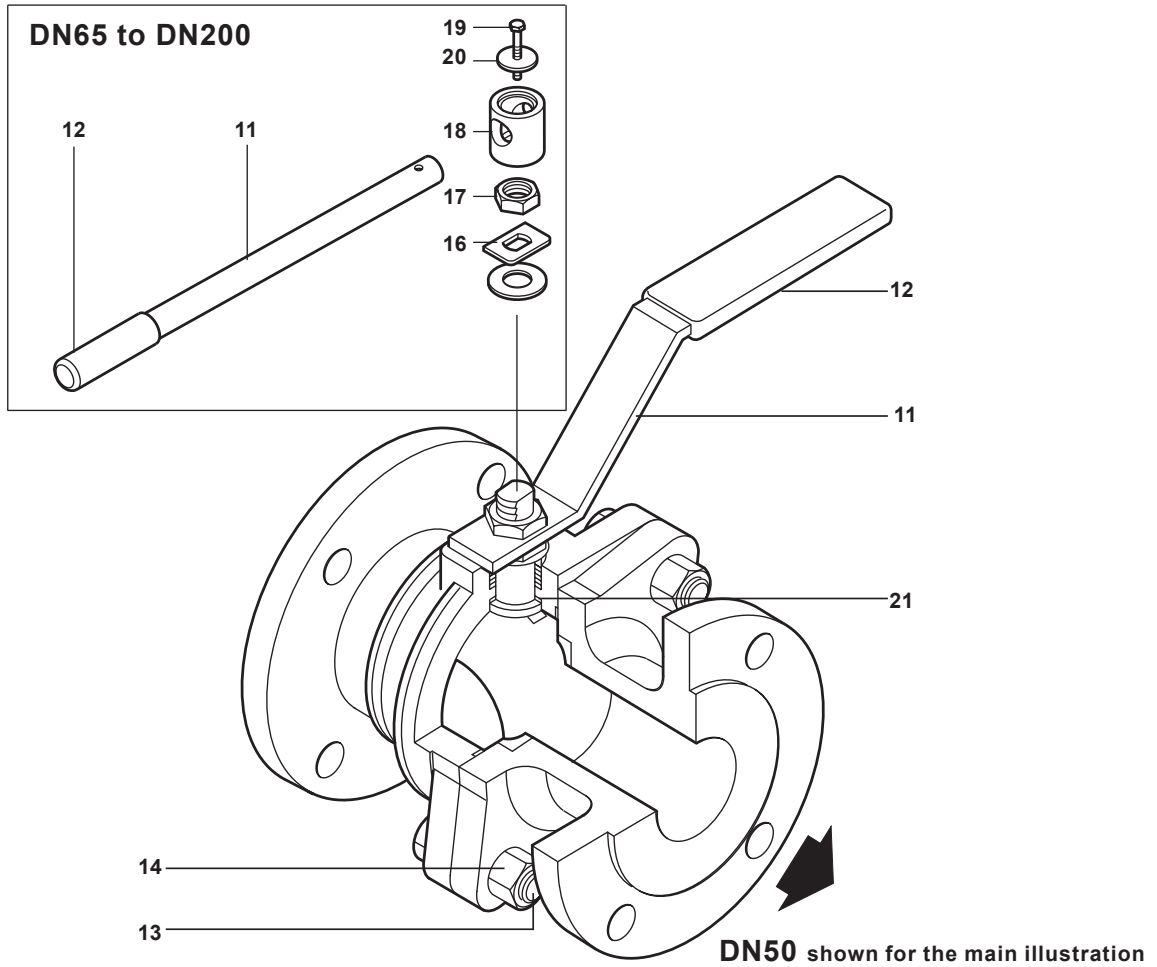

No.	Part	Material	
11	Handle	Zinc plated carbon steel	SAE 1010
12	Grip	Vinyl (Orange)	
13	Bolt	Zinc plated carbon steel	Grade 5
14	Nut	Zinc plated carbon steel	
15	Stop screw (Not shown)	Zinc plated carbon steel	SAE 12L14
16	Stop plate	Zinc plated carbon steel	SAE 1010
17	Nut	Zinc plated carbon steel	Grade 5
18	Handle adaptor	Zinc plated SG iron	
19	Screw	Carbon steel	Grade 5
20	Adapter washer	Carbon steel	SAE 1045
21	Stem seal	PTFE	

Dimensions/weights (approximate) in mm and kg

PN16 DIN F1 flanges

Size	A	B	C	D	E	F	Weight
DN50	230	185	140	165	50	60	12.0
DN65	290	415	166	185	64	74	18.0
DN80	310	415	180	200	75	88	22.0
DN100	350	700	218	220	100	105	34.3
DN150	480	850	266	285	150	197	77.8
DN200	600	950	311	340	200	228	128.5

PN16 DIN F4/F5 flanges

Size	A	B	C	D	E	F	Weight
DN50	150	185	140	165	50	60	11.4
DN65	170	415	166	185	64	74	16.2
DN80	180	415	180	200	75	88	19.0
DN100	190	700	218	220	100	105	29.9
DN150	350	850	266	285	150	197	72.4
DN200	400	950	311	340	200	228	119.3

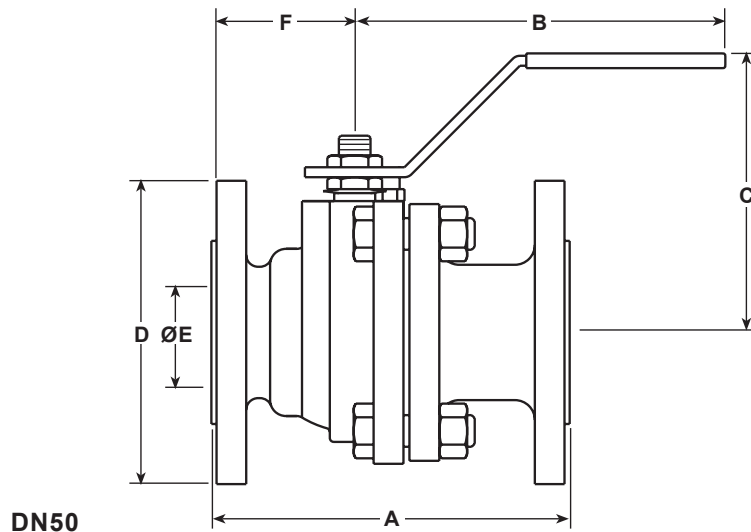
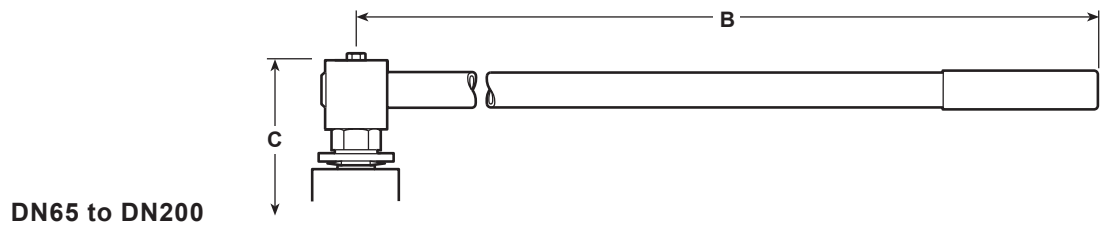

K_v values

DN	50	65	80	100	150	200	For conversion:
K_v	300	430	770	1030	2390	4530	C_v (UK) = $K_v \times 0.963$ C_v (US) = $K_v \times 1.156$

Operating torque (N m)

DN	50	65	80	100	150	200	
N m	40	50	70	200	600	750	The torque figures shown are for a valve at maximum operating pressure that is operated frequently. Valves that are subject to long static periods, may require greater break-out torque.

Safety information, installation and maintenance

For full details see the Installation and Maintenance Instructions supplied with the product.

How to order

Specify:	Size	Seats	V	=	PTFE	Example: 1 off Spirax Sarco DN80 flanged EN 1092 PN16 F1 M31V2 ISO ball valve.
	Model					
	Seats		2	=	Carbon steel	
	Material	Body material	3	=	Stainless steel	

Spare parts

The spare parts available are shown in solid outline. Parts drawn in a grey line are not supplied as spares.

Available spares

Seats, stem seals and body gasket set **5, 6, 7, 21**

How to order spares

Always order spares by using the description given in the column headed 'Available spares' and state the size and type of ball valve.

Example: 1 - Seat, stem seals and body gasket set for a Spirax Sarco DN80 flanged EN 1092 PN16 F1 M31V2 ISO ball valve.

