



M21Hi ISO Reduced Bore Ball Valve DN15 to DN150 Flanged PN40

Description

The M21Hi is a reduced bore ball valve, with a single piece body, having ISO mounting as standard. As a main feature the valve has a special ball which has received a surface hardening and also benefits from having reinforced PEEK seats. The M21Hi can be used on applications that use steam and other industrial fluids for services ranging from vacuum to the higher temperatures and pressures. The M21Hi has been designed for use as an isolating valve, not a control valve.

Available types

M21Hi2 ISO Zinc plated carbon steel body, reinforced PEEK seats.

M21Hi3 ISO Stainless steel body, reinforced PEEK seats.

Standards

This product fully complies with the requirements of the Pressure Equipment Directive (PED) and carries the  mark when so required.

Certification

This product is available with certification to EN 10204 3.1.

Note: All certification/inspection requirements must be stated at the time of order placement.

Sizes and pipe connections

DN15, DN20, DN25, DN32, DN40, DN50, DN65, DN80, DN100 and DN150

Standard flange: EN 1092 PN40

Face-to-face dimensions:

- DN15 to DN100 according to DIN 3202 F4.
- DN25 to DN150 according to BS 2080.

Technical data

Flow characteristic	Modified linear
Port	Reduced bore
Leakage test procedure to ISO 5208 (Rate A)/EN 12266-1 (Rate A)	
Antistatic device	Complies with ISO 7121 and BS 5351

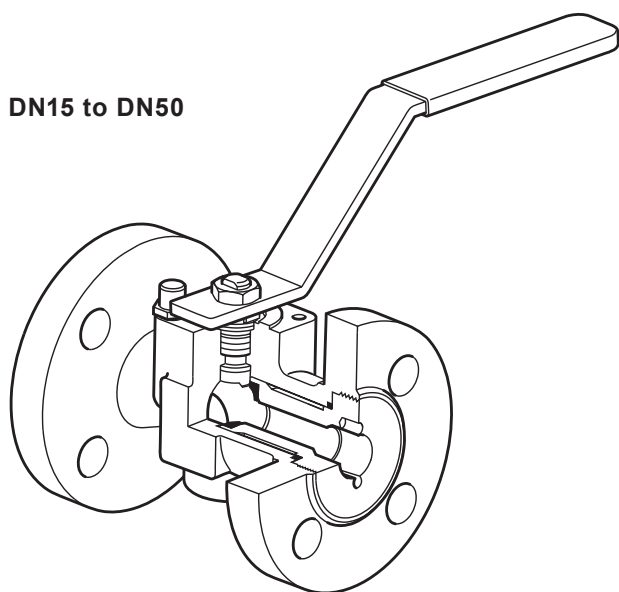

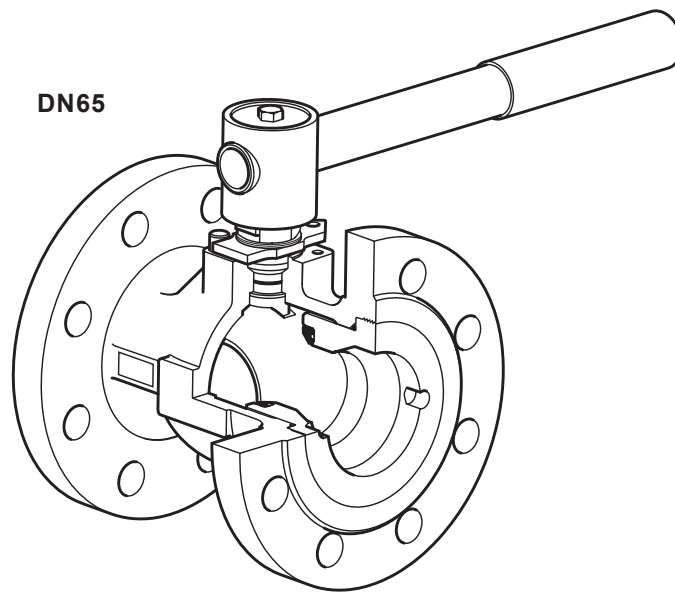

DN15 to DN50

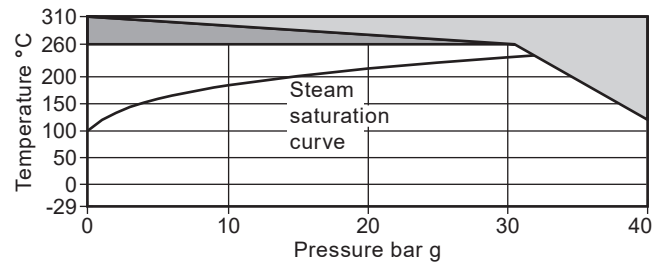

DN65

Pressure/temperature limits



 The product **must not** be used in this region.

 The product can only be used in this region for short periods of time.

Body design conditions	PN40
PMA Maximum allowable pressure	40 bar g @ 120 °C
TMA Maximum allowable temperature	310 °C @ 0 bar g
Minimum allowable temperature	-29 °C
PMO Maximum operating pressure for saturated steam service	32 bar g
TMO Maximum operating temperature	260 °C @ 0 bar g
Minimum operating temperature	-29 °C
Note: For lower operating temperatures consult Spirax Sarco.	
ΔPMX Maximum differential pressure is limited to the PMO	
Designed for a maximum cold hydraulic test pressure of: 60 bar g	

Materials - DN15 to DN50

No.	Part		Material	
1	Body	M21Hi2 ISO	Zinc plated carbon steel	ASTM A216 WCB
		M21Hi3 ISO	Stainless steel	ASTM A351 CF8M
2	Insert	M21Hi2 ISO	Zinc plated carbon steel	SAE 1040
		M21Hi3 ISO	Stainless steel	AISI 316
3	Ball		Stainless steel	AISI 316 hardened surface
4	Stem		Stainless steel	AISI 316/AISI 420
5	Seats		PEEK	Reinforced
6	Insert gasket		Graphite	
7	Seat 'O' ring		EPDM	Geothermal
8	Stem seals		Graphite	
9	Stem seals		PEEK	Reinforced
10	Stem seals		Stainless steel	AISI 304
13	Separator		Zinc plated carbon steel	SAE 1010
14	Belleville washer		Stainless steel	AISI 301
15	Gland nut		Zinc plated carbon steel	SAE 1010/SAE 12L14
16	Upper stem nut		Zinc plated carbon steel	SAE 1010/SAE 12L14
17	Locking plate		Stainless steel	AISI 304
18	Name-plate		Stainless steel	AISI 430
20	Lever		Zinc plated carbon steel	SAE 1010
21	Grip		Vinyl	
25	Stop screw		Zinc plated carbon steel	SAE 12L14
26	Split lock washer		Stainless steel	AISI 304

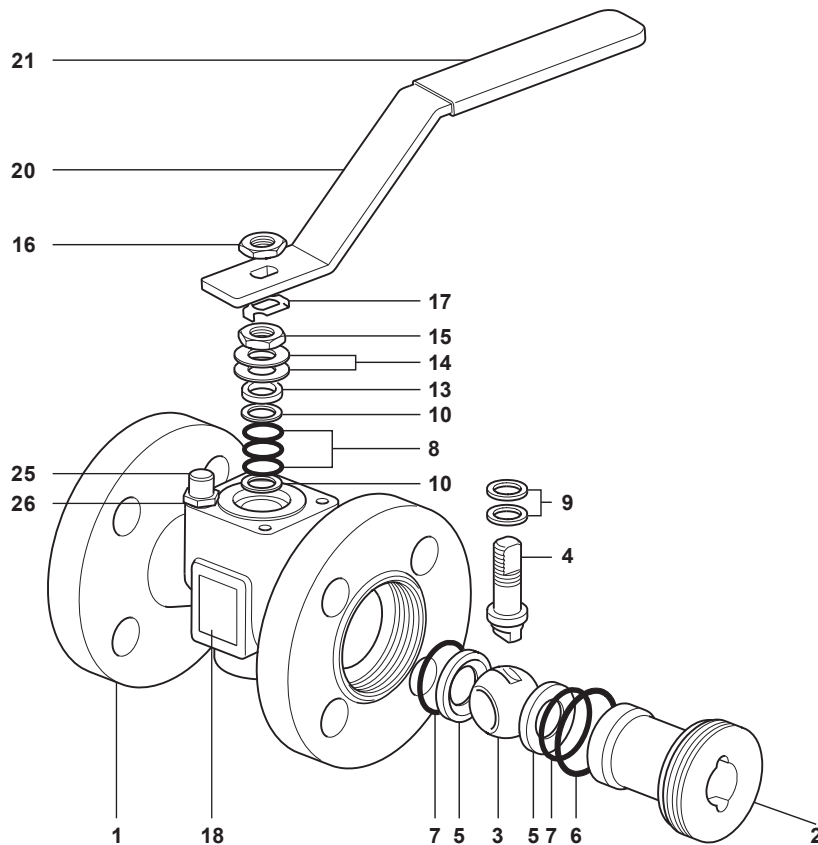

Materials - DN65

No.	Part	Material	
1	Body	M21Hi2 ISO	Zinc plated carbon steel ASTM A216 WCB
		M21Hi3 ISO	Stainless steel ASTM A351 CF8M
2	Insert	M21Hi2 ISO	Zinc plated carbon steel SAE 1040
		M21Hi3 ISO	Stainless steel AISI 316
3	Ball	Stainless steel	AISI 316 hardened surface
4	Stem	Stainless steel	AISI 316/AISI 420
5	Seats	PEEK	Reinforced
6	Insert gasket	Graphite	
7	Seat 'O' ring	EPDM	Geothermal
8	Stem seal	EPDM	Geothermal
11	Lower stem seal	PEEK	Reinforced
12	Upper stem packing	Graphite	
13	Separator	Zinc plated carbon steel	SAE 1010
14	Belleville washer	Stainless steel	AISI 301
15	Gland nut	Zinc plated carbon steel	SAE 1010/SAE 12L14

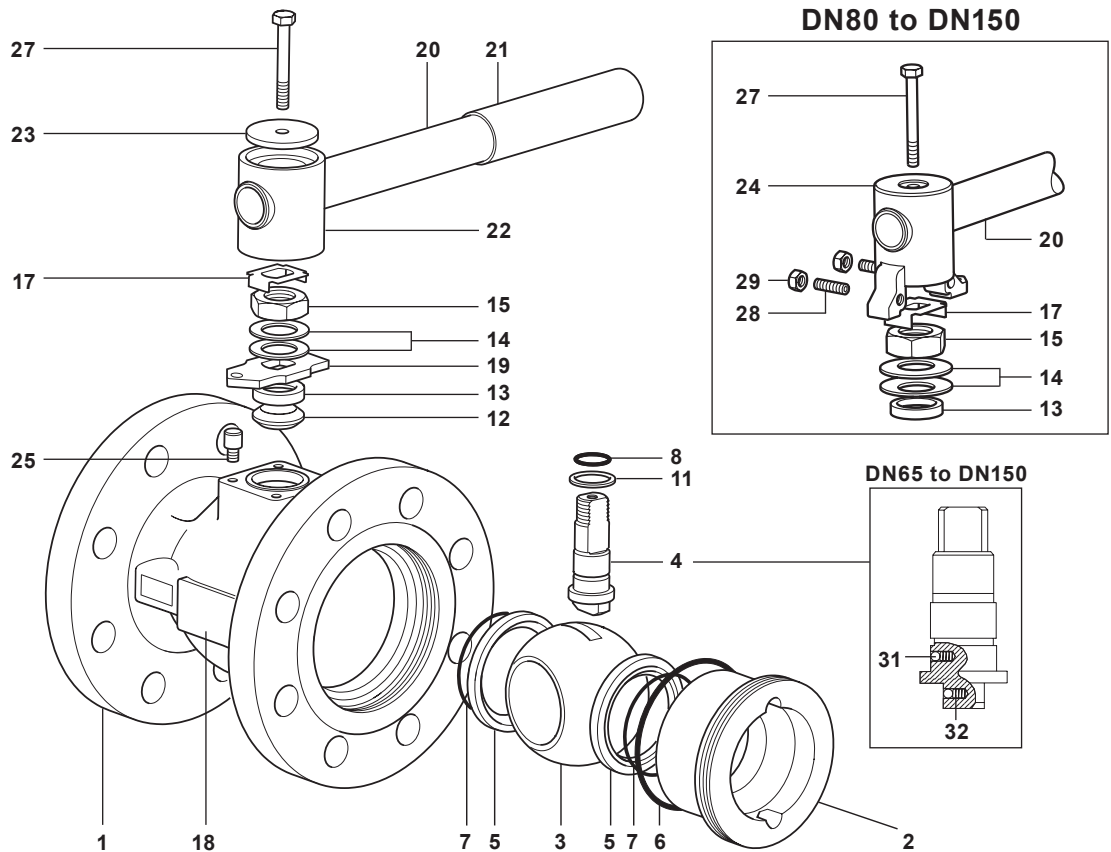

Materials - DN65 (continued)

No.	Part		Material	
17	Locking plate		Stainless steel	AISI 304
18	Name-plate		Stainless steel	AISI 430
19	Stop plate with indicator	DN65 only	Zinc plated carbon steel	SAE 1010
20	Lever		Zinc plated carbon steel	SAE 1010
21	Grip		Vinyl	
22	Adaptor	DN65 only	Zinc plated SG iron	
23	Adaptor plate	DN65 only	Zinc plated carbon steel	SAE 1010
24	Adaptor with indicator	DN80 to DN150	Zinc plated SG iron	
25	Stop screw	DN80 to DN150	Zinc plated carbon steel	SAE 12L14
27	Adaptor screw		Zinc plated carbon steel	Grade 5
28	Stop screw	DN80 to DN150	Carbon steel	
29	Adaptor hex. nut	DN80 to DN150	Zinc plated carbon steel	
31	Antistatic device ball		Stainless steel	AISI 302
32	Antistatic device spring		Stainless steel	AISI 301

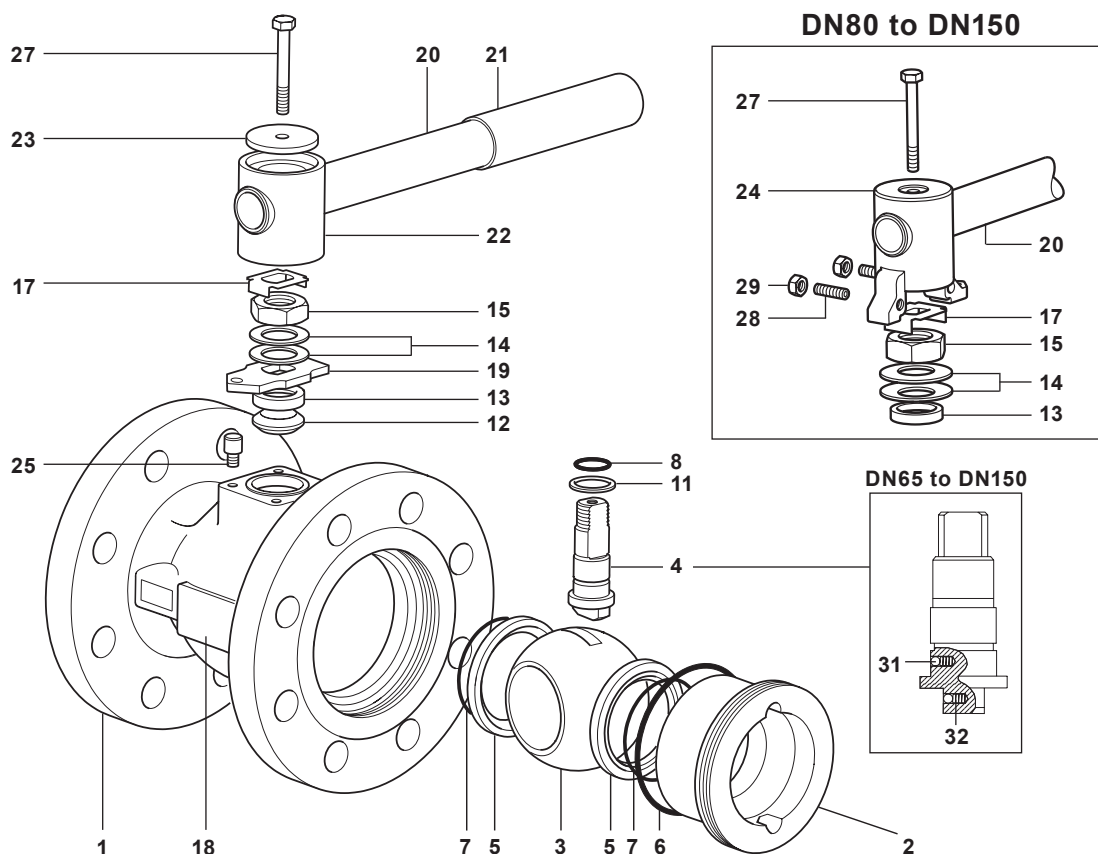

Dimensions/weights (approximate) in mm and kg

PN40 DIN 3202 F4 flanges

Size	A	B	C	D	E	F	Weight
DN15	115	57	162	95	95	13	2.5
DN20	120	60	162	105	95	13	3.2
DN25	125	62	162	115	101	19	4.0
DN32	130	65	182	140	106	25	5.5
DN40	140	70	186	150	118	30	6.9
DN50	150	75	186	165	123	37	9.3
DN65	170	79	278	185	144	50	13.4
DN80	180	91	417	200	157	57	17.7
DN100	190	98	517	235	172	75	25.0
DN150	-	-	-	-	-	-	-

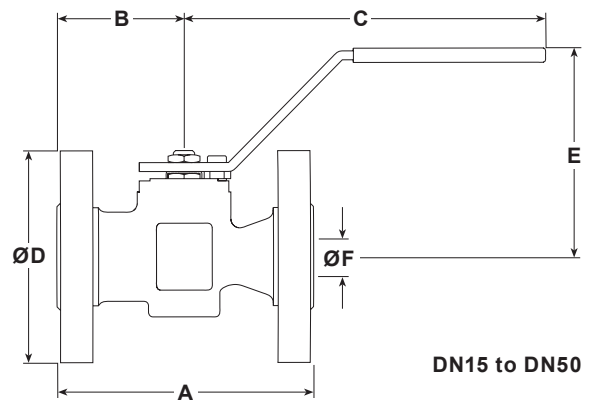

PN40 BS 2080 flanges

Size	A	B	C	D	E	F	Weight
DN15	-	-	-	-	-	-	-
DN20	-	-	-	-	-	-	-
DN25	165	62	162	115	101	19	4.2
DN32	178	65	182	140	106	25	5.9
DN40	190	70	186	150	118	30	7.4
DN50	216	75	186	165	123	37	10.2
DN65	241	79	278	185	144	50	14.9
DN80	283	91	417	200	157	57	20.2
DN100	305	98	517	235	172	75	29.4
DN150	403	130	700	300	205	100	56.9

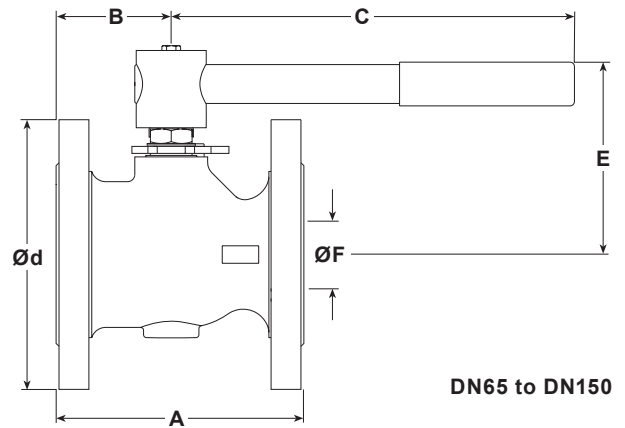

K_v values

DN	15	20	25	32	40	50	65	80	100	150
K _v	10	10	30	40	81	103	197	248	581	735

For conversion

$$C_v \text{ (UK)} = K_v \times 0.963$$

$$C_v \text{ (US)} = K_v \times 1.156$$

Operating torque (N m)

DN	15	20	25	32	40	50	65	80	100	150
N m	15	15	20	25	35	60	100	120	170	400

Note: The torque figures shown are for a valve that is frequently operated at the maximum operating pressure. Valves that are subject to long static periods, may require a greater break-out torque.

Safety information, installation and maintenance

For full details see the Installation and Maintenance Instructions supplied with the product.

How to order

Specify	Body material
	2 = Zinc plated carbon steel
	3 = Stainless steel

Example: 1 off Spirax Sarco DN50 M21Hi2 ISO ball valve having flanged EN 1092 PN40 connections. Face-to-face according to BS 2080.

Optional extras:

- Self-venting ball.
- Extended stems to allow full insulation: 50 mm (2") for the DN15 to DN50 and 100 mm (4") for the DN15 to DN150.
- Lockable handle.
- 100 mm extended stem with lockable handle.

DN15 to DN50 - Spare parts

The spare parts available are shown in solid outline. Parts drawn in a grey line are not supplied as spares.

Available spares

Seats, insert gasket, seat 'O' rings and stem seals

5, 6, 7, 8, 9, 10

How to order spares

Always order spares by using the description given in the column headed 'Available spares' and state the size and type of ball valve.

Example: 1 set of seats, insert gasket, seat 'O' rings and stem seals for a Spirax Sarco DN50 flanged PN40 M21Hi2 ball valve.

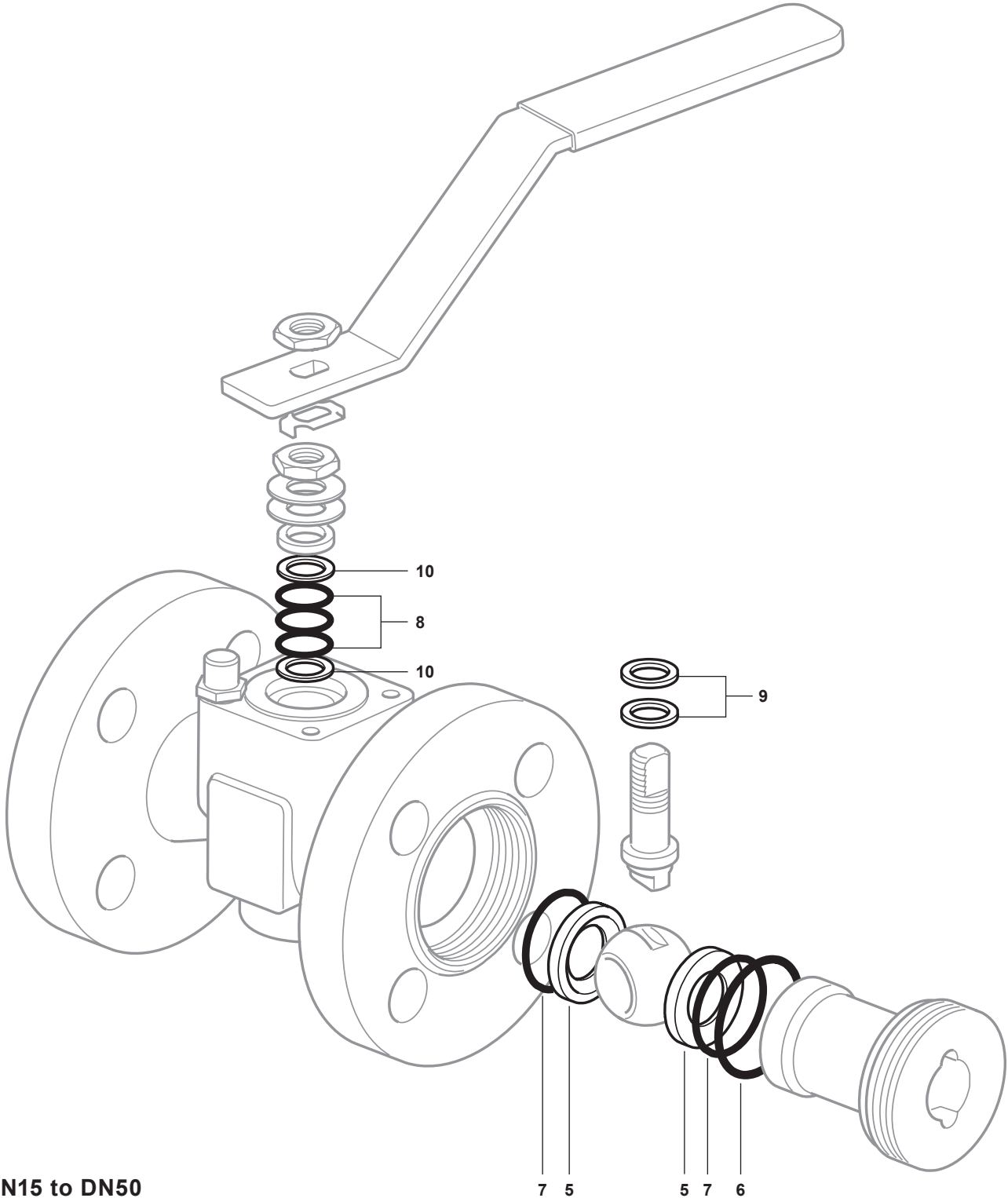

DN65 to DN150 - Spare parts

The spare parts available are shown in solid outline. Parts drawn in a grey line are not supplied as spares.

Available spares

Seats, insert gasket, seat 'O' ring, stem 'O' ring, lower stem seal and upper stem packing

5, 6, 7, 8, 11, 12

How to order spares

Always order spares by using the description given in the column headed 'Available spares' and state the size and type of ball valve.

Example: 1 set of seats, insert gasket, seat 'O' ring, stem 'O' ring, lower stem seal and upper stem packing for a Spirax Sarco DN50 flanged PN40 M21Hi2 ball valve.

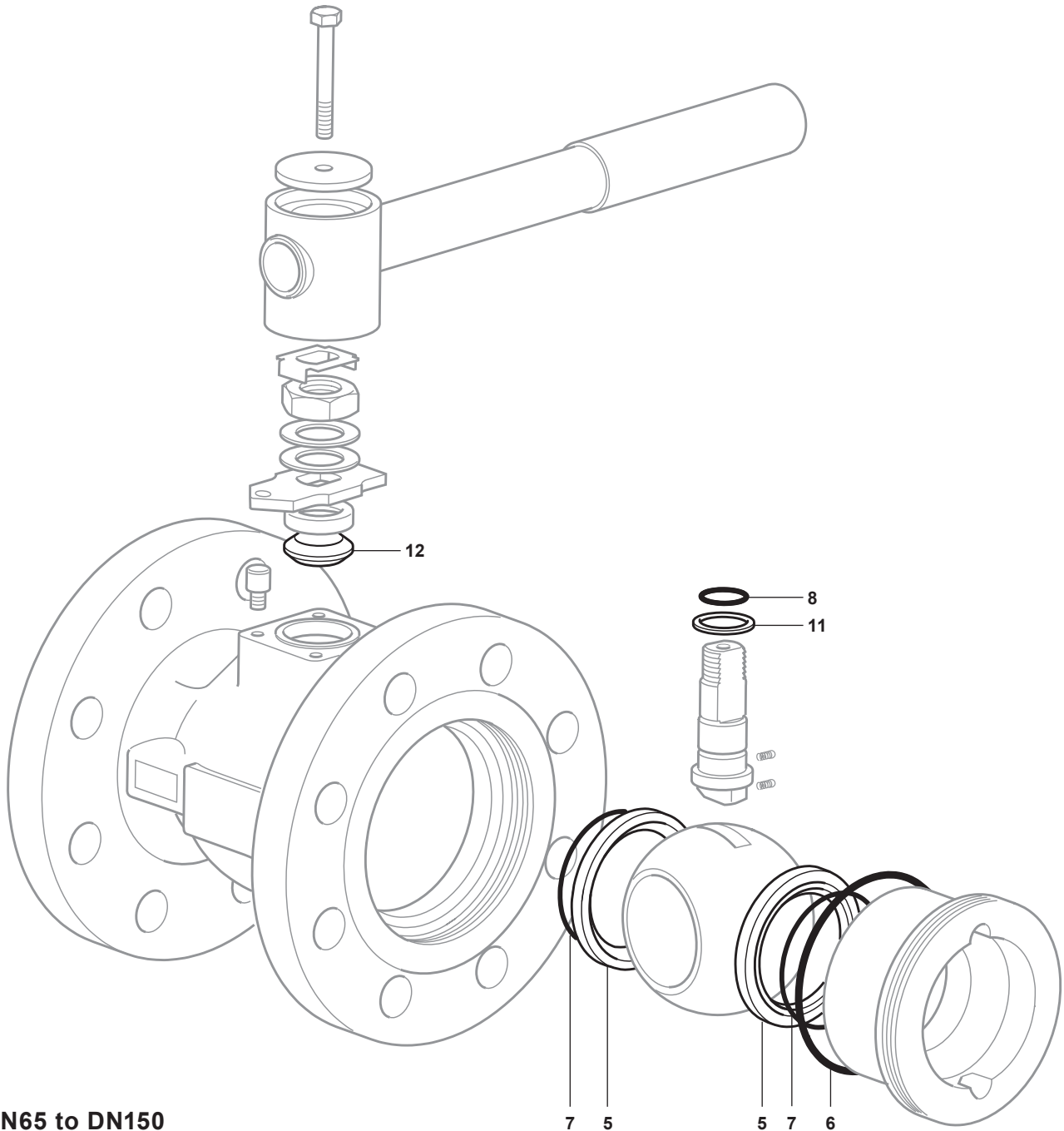

DN65 to DN150