



LCV3, LCV4, LCV6 and LCV7 Lift Check Valves

Description

The LCV3, LCV4, LCV6 and LCV7 lift check valves are designed in accordance with EN 12516 and ASME B16.34 to prevent reverse flow in the installations. The design of these valves allows them to be easily serviced without removing the valve from the pipeline - See Spare parts, page 8.

Available types:

- LCV3** Cast iron bodied with stainless steel internals.
- LCV4** Cast steel bodied with stainless steel internals.
- LCV6** Stainless steel bodied with stainless steel internals.
- LCV7** SG iron bodied with stainless steel internals.

Optional for the LCV4:

High temperature bolting (stainless steel A2-80).

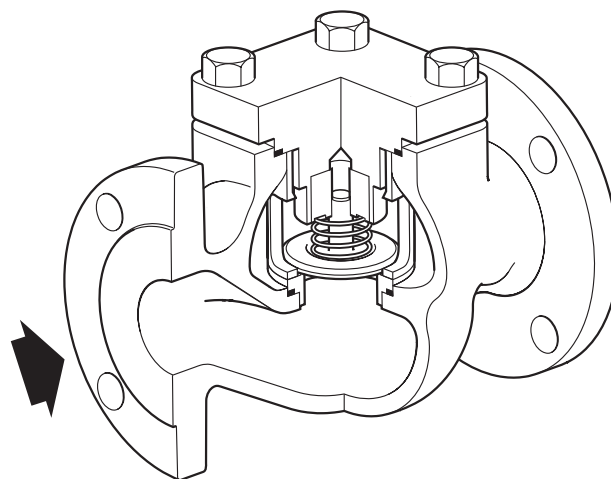

Standards

These products fully comply with the requirements of the Pressure Equipment Directive 2014/68/EU and carries the **CE** mark when so required.

Standard shut-off

This range of lift check valves conform to EN 12266-1: 2003 Rate F.

Certification

With the exception of the LCV3 these products are available with certification to EN 10204 3.1. **Note:** All certification / inspection requirements must be stated at the time of order placement.

Sizes and pipe connections

Unit	LCV3			LCV4			LCV6			LCV7		
	PN16 JIS/KS 10	ASME 125	BSP NPT	PN40 JIS/KS 20	ASME 150 ASME 300	NPT SW	PN40 JIS/KS 20	ASME 150 ASME 300	BSP NPT SW	PN16 PN25 JIS/KS 10	ASME 125 ASME 250	BSP NPT
DN15 1/2"
DN20 3/4"
DN25 1"
DN32 1 1/4"
DN40 1 1/2"
DN50 2"
DN65 2 1/2"	
DN80 3"	
DN100 4"	

LCV3 pressure / temperature limits

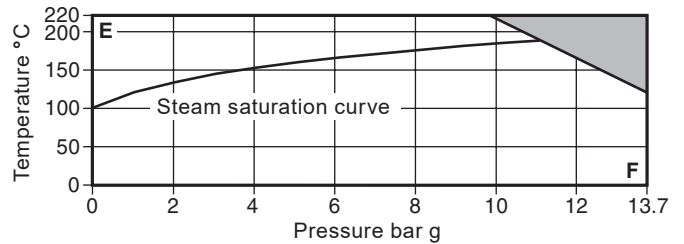
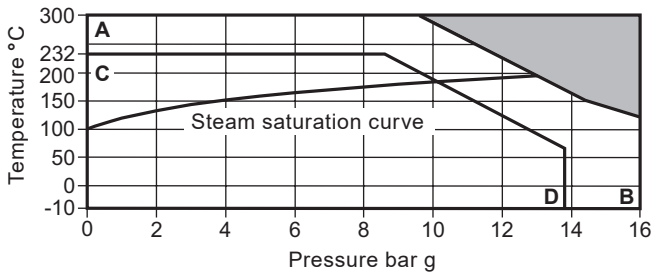

The product **must not** be used in this region.

A - B Screwed BSP and flanged EN 1092 PN16.

C - D Screwed NPT, socket weld and flanged ASME 125.

The product **must not** be used in this region.

E - F Flanged JIS / KS 10.

Screwed and Flanged EN 1092 PN16

Body design conditions	PN16
PMA Maximum allowable pressure	16 bar g @ 120°C
TMA Maximum allowable temperature	300°C @ 9.6 bar g
Minimum allowable temperature	-10°C
PMO Maximum operating pressure for saturated steam service	13 bar g
TMO Maximum operating temperature	300°C @ 9.6 bar g
Minimum operating temperature	-10°C
Note: For lower operating temperatures consult Spirax Sarco.	
Designed for a maximum cold hydraulic test pressure of:	24 bar g

Flanged ASME 125

Body design conditions	ASME 125
PMA Maximum allowable pressure	13.8 bar g @ 65°C
TMA Maximum allowable temperature	232°C @ 8.6 bar g
Minimum allowable temperature	-10°C
PMO Maximum operating pressure for saturated steam service	10 bar g
TMO Maximum operating temperature	232°C @ 8.6 bar g
Minimum operating temperature	-10°C
Note: For lower operating temperatures consult Spirax Sarco.	
Designed for a maximum cold hydraulic test pressure of:	20.5 bar g

Flanged JIS / KS 10

Body design conditions	JIS / KS 10
PMA Maximum allowable pressure	13.7 bar g @ 120°C
TMA Maximum allowable temperature	220°C @ 9.8 bar g
Minimum allowable temperature	0°C
PMO Maximum operating pressure for saturated steam service	11.2 bar g
TMO Maximum operating temperature	220°C @ 9.8 bar g
Minimum operating temperature	0°C
Note: For lower operating temperatures consult Spirax Sarco.	
Designed for a maximum cold hydraulic test pressure of:	20 bar g

LCV4 pressure / temperature limits

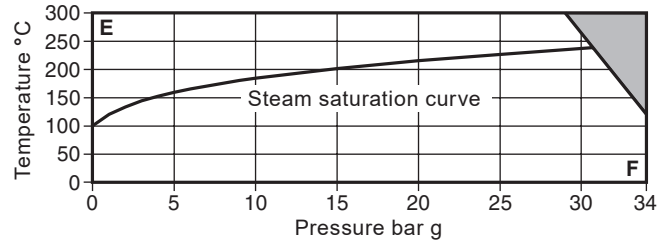
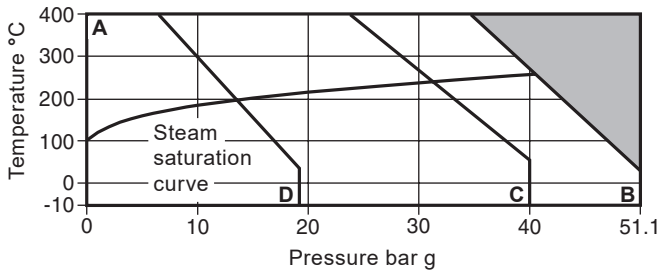

The product **must not** be used in this region.

The product **must not** be used in this region.

A - B Screwed NPT, socket weld and flanged ASME 300.

E - F Flanged JIS / KS 20.

A - C Flanged EN 1092 PN40.

A - D Flanged ASME 150.

	Body design conditions	PN40
Flanged EN 1092 PN40	PMA	Maximum allowable pressure 40 bar g @ 50°C
	TMA	Maximum allowable temperature 300°C @ 27.6 bar g
		Maximum allowable temperature with high temperature bolting 400°C @ 23.8 bar g
		Minimum allowable temperature -10°C
	PMO	Maximum operating pressure for saturated steam service 31.1 bar g
	TMO	Maximum operating temperature 300°C @ 27.6 bar g
		Maximum operating temperature with high temperature bolting 400°C @ 23.8 bar g
		Minimum operating temperature -10°C
		Note: For lower operating temperatures consult Spirax Sarco.
		Designed for a maximum cold hydraulic test pressure of: 60 bar g
	Body design conditions	ASME 150
Flanged ASME 150	PMA	Maximum allowable pressure 19.3 bar g @ 38°C
	TMA	Maximum allowable temperature 300°C @ 10.2 bar g
		Maximum allowable temperature with high temperature bolting 400°C @ 6.5 bar g
		Minimum allowable temperature -10°C
	PMO	Maximum operating pressure for saturated steam service 13.9 bar g
	TMO	Maximum operating temperature 300°C @ 10.2 bar g
		Maximum operating temperature with high temperature bolting 400°C @ 6.5 bar g
		Minimum operating temperature -10°C
		Note: For lower operating temperatures consult Spirax Sarco.
		Designed for a maximum cold hydraulic test pressure of: 30 bar g
	Body design conditions	ASME 300
Screwed NPT Socket weld and Flanged ASME 300	PMA	Maximum allowable pressure 51.1 bar g @ 38°C
	TMA	Maximum allowable temperature 300°C @ 39.8 bar g
		Maximum allowable temperature with high temperature bolting 400°C @ 34.7 bar g
		Minimum allowable temperature -10°C
	PMO	Maximum operating pressure for saturated steam service 41.8 bar g
	TMO	Maximum operating temperature 300°C @ 39.8 bar g
		Maximum operating temperature with high temperature bolting 400°C @ 34.7 bar g
		Minimum operating temperature -10°C
		Note: For lower operating temperatures consult Spirax Sarco.
		Designed for a maximum cold hydraulic test pressure of: 77 bar g
	Body design conditions	JIS / KS 20
Flanged JIS / KS 20	PMA	Maximum allowable pressure 34 bar g @ 120°C
	TMA	Maximum allowable temperature 300°C @ 32 bar g
		Minimum allowable temperature 0°C
	PMO	Maximum operating pressure for saturated steam service 30 bar g
	TMO	Maximum operating temperature 300°C @ 32 bar g
		Minimum operating temperature 0°C
		Note: For lower operating temperatures consult Spirax Sarco.
		Designed for a maximum cold hydraulic test pressure of: 51 bar g

LCV6 pressure / temperature limits

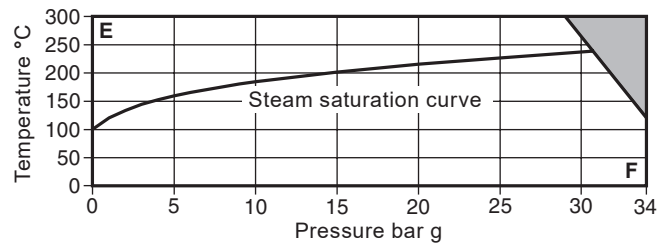
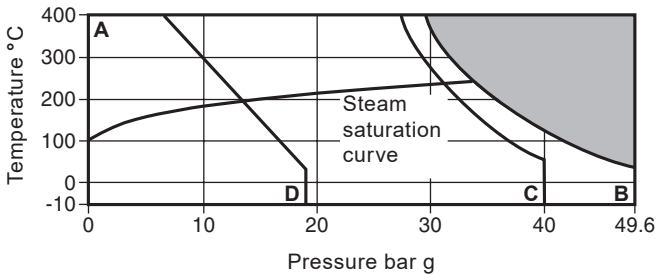

The product **must not** be used in this region.

A - B Screwed NPT, socket weld and flanged ASME 300.

The product **must not** be used in this region.

E - F Flanged JIS / KS 10.

A - C Screwed BSP and flanged EN 1092 PN40.

A - D Flanged ASME 150.

Screwed BSP and Flanged EN 1092 PN40	Body design conditions	PN40
	PMA Maximum allowable pressure	40 bar g @ 50°C
	TMA Maximum allowable temperature	400°C @ 27.4 bar g
	Minimum allowable temperature	-10°C
	PMO Maximum operating pressure for saturated steam service	32.3 bar g
	TMO Maximum operating temperature	400°C @ 27.4 bar g
	Minimum operating temperature	-10°C
	Note: For lower operating temperatures consult Spirax Sarco.	
Designed for a maximum cold hydraulic test pressure of:	60 bar g	
Screwed NPT Socket weld and Flanged ASME 300	Body design conditions	ASME 300
	PMA Maximum allowable pressure	49.6 bar g @ 38°C
	TMA Maximum allowable temperature	400°C @ 29.4 bar g
	Minimum allowable temperature	-10°C
	PMO Maximum operating pressure for saturated steam service	34 bar g
	TMO Maximum operating temperature	400°C @ 29.4 bar g
	Minimum operating temperature	-10°C
	Note: For lower operating temperatures consult Spirax Sarco.	
Designed for a maximum cold hydraulic test pressure of:	76 bar g	
Flanged ASME 150	Body design conditions	ASME 150
	PMA Maximum allowable pressure	19 bar g @ 38°C
	TMA Maximum allowable temperature	400°C @ 6.5 bar g
	Minimum allowable temperature	-10°C
	PMO Maximum operating pressure for saturated steam service	13.8 bar g
	TMO Maximum operating temperature	400°C @ 6.5 bar g
	Minimum operating temperature	-10°C
	Note: For lower operating temperatures consult Spirax Sarco.	
Designed for a maximum cold hydraulic test pressure of:	30 bar g	
Flanged JIS / KS 20	Body design conditions	JIS / KS 20
	PMA Maximum allowable pressure	34 bar g @ 120°C
	TMA Maximum allowable temperature	300°C @ 32 bar g
	Minimum allowable temperature	0°C
	PMO Maximum operating pressure for saturated steam service	23.5 bar g
	TMO Maximum operating temperature	300°C @ 32 bar g
	Minimum operating temperature	0°C
	Note: For lower operating temperatures consult Spirax Sarco.	
Designed for a maximum cold hydraulic test pressure of:	51 bar g	

LCV7 pressure / temperature limits

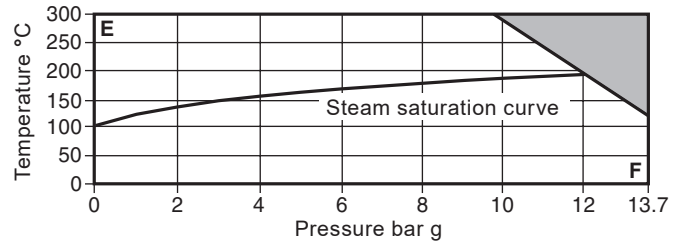
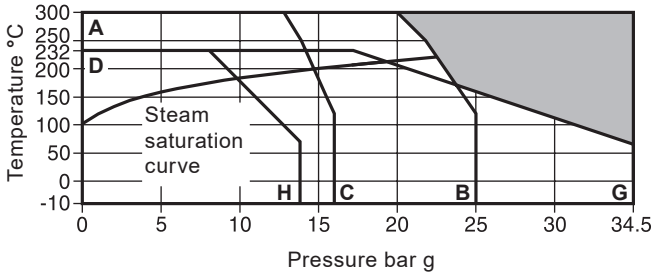

The product **must not** be used in this region.

The product **must not** be used in this region.

A - B Screwed BSP and flanged EN 1092 PN25.

E - F Flanged JIS / KS 10.

A - C Screwed NPT and flanged EN 1092 PN16.

D - G Flanged ASME 250.

D - H Flanged ASME 125.

Flanged EN 1092 PN16	Body design conditions	PN16
	PMA Maximum allowable pressure	16 bar g @ 120°C
	TMA Maximum allowable temperature	300°C @ 12.8 bar g
	Minimum allowable temperature	-10°C
	PMO Maximum operating pressure for saturated steam service	14.7 bar g
	TMO Maximum operating temperature	300°C @ 12.8 bar g
	Minimum operating temperature	-10°C
Note: For lower operating temperatures consult Spirax Sarco.		
Designed for a maximum cold hydraulic test pressure of:	24 bar g	
Screwed BSP and Flanged EN 1092 PN25	Body design conditions	PN25
	PMA Maximum allowable pressure	25 bar g @ 120°C
	TMA Maximum allowable temperature	300°C @ 20 bar g
	Minimum allowable temperature	-10°C
	PMO Maximum operating pressure for saturated steam service	22.5 bar g
	TMO Maximum operating temperature	300°C @ 20 bar g
	Minimum operating temperature	-10°C
Note: For lower operating temperatures consult Spirax Sarco.		
Designed for a maximum cold hydraulic test pressure of:	38 bar g	
Flanged ASME 125	Body design conditions	ASME 125
	PMA Maximum allowable pressure	13.8 bar g @ 65°C
	TMA Maximum allowable temperature	232°C @ 8.6 bar g
	Minimum allowable temperature	-10°C
	PMO Maximum operating pressure for saturated steam service	10 bar g
	TMO Maximum operating temperature	232°C @ 8.6 bar g
	Minimum operating temperature	-10°C
Note: For lower operating temperatures consult Spirax Sarco.		
Designed for a maximum cold hydraulic test pressure of:	20.5 bar g	
Screwed NPT and Flanged ASME 250	Body design conditions	ASME 250
	PMA Maximum allowable pressure	34.5 bar g @ 65°C
	TMA Maximum allowable temperature	232°C @ 17.2 bar g
	Minimum allowable temperature	-10°C
	PMO Maximum operating pressure for saturated steam service	19.4 bar g
	TMO Maximum operating temperature	232°C @ 17.2 bar g
	Minimum operating temperature	-10°C
Note: For lower operating temperatures consult Spirax Sarco.		
Designed for a maximum cold hydraulic test pressure of:	52 bar g	
Flanged JIS / KS 10	Body design conditions	JIS / KS 10
	PMA Maximum allowable pressure	13.7 bar g @ 120°C
	TMA Maximum allowable temperature	300°C @ 9.8 bar g
	Minimum allowable temperature	0°C
	PMO Maximum operating pressure for saturated steam service	12.3 bar g
	TMO Maximum operating temperature	300°C @ 9.8 bar g
	Minimum operating temperature	0°C
Note: For lower operating temperatures consult Spirax Sarco.		
Designed for a maximum cold hydraulic test pressure of:	20 bar g	

Materials

No.	Part	Material	Standard			
			PN/BSP	ASME/NPT/SW		
1 and 2	Body and cover	LCV3 ASME	Cast iron body with SG iron cover	Cover (1)	EN 1561 GJL250	ASTM A395
		PN	SG iron body with cast iron cover	Body (2)	EN 1563 GJS400-15	ASTM A126 Class B
		LCV4	Carbon steel		EN 10213 1.0619+N	ASTM A216 WCB
		LCV6	Stainless steel		EN 10213 1.4408	ASTM A351-CF8M
		LCV7	SG iron		EN 1563 GJS400-18LT	ASTM A395
3	Gasket		Reinforced exfoliated graphite		Graphite	Graphite
4 and 5	Seat and guide	LCV3	Stainless steel		431	431
		LCV4	Stainless steel		431	431
		LCV6	Stainless steel		316L	316L
		LCV7	Stainless steel		431	431
6	Disc		Stainless steel		316L	316L
7	Spring		Stainless steel		316 S 42	316 S 42
8	Bolt	LCV3	Cast steel		Grade 8.8	Grade 8.8
		LCV4	Cast steel		Grade 8.8	Grade 8.8
		LCV6	Stainless steel		A2-80	A2-80
		LCV7	Cast steel		Grade 8.8	Grade 8.8
9	Seat retainer		Stainless steel		316L	316L

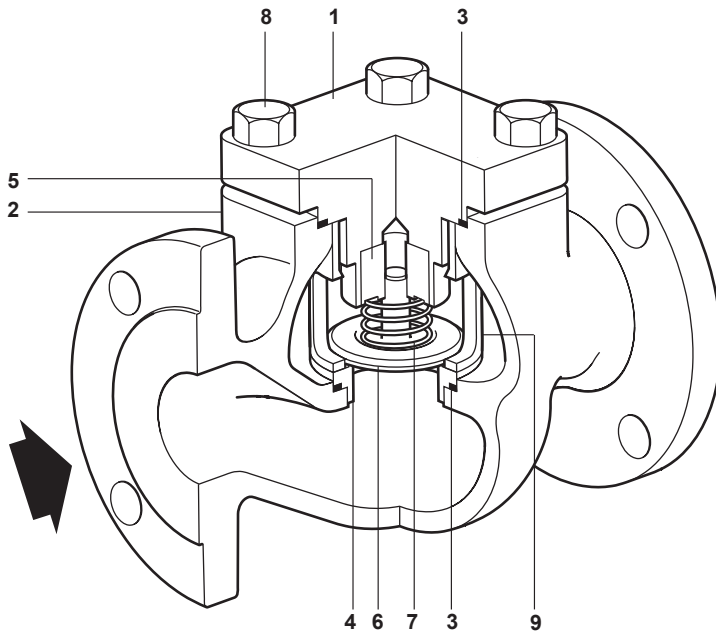

Weights (approximate) in kg

Unit		LCV3		LCV4	
		Flanged	Screwed	Flanged	Screwed Socket weld
DN15	½"	4.30	3.10	5.05	3.65
DN20	¾"	5.50	4.10	6.43	5.33
DN25	1"	5.82	4.10	6.58	4.18
DN32	1¼"	10.23	7.20	12.89	9.59
DN40	1½"	11.43	8.00	14.35	9.55
DN50	2"	14.96	10.50	16.86	12.06
DN65	2½"	27.04		32.25	
DN80	3"	29.47		36.02	
DN100	4"	48.93		52.06	

Unit		LCV6		LCV7	
		Flanged	Screwed Socket weld	Flanged	Screwed
DN15	½"	5.19	3.79	4.64	3.24
DN20	¾"	6.60	5.50	5.89	4.29
DN25	1"	6.77	4.37	6.04	3.74
DN32	1¼"	13.37	10.07	11.99	8.69
DN40	1½"	14.77	9.97	13.18	9.28
DN50	2"	17.51	12.71	15.65	10.65
DN65	2½"	33.13		29.53	
DN80	3"	37.00		33.00	
DN100	4"	53.47		48.82	

Dimensions (approximate) in mm

Please note: Flanged ASME versions are (approximate) in inches

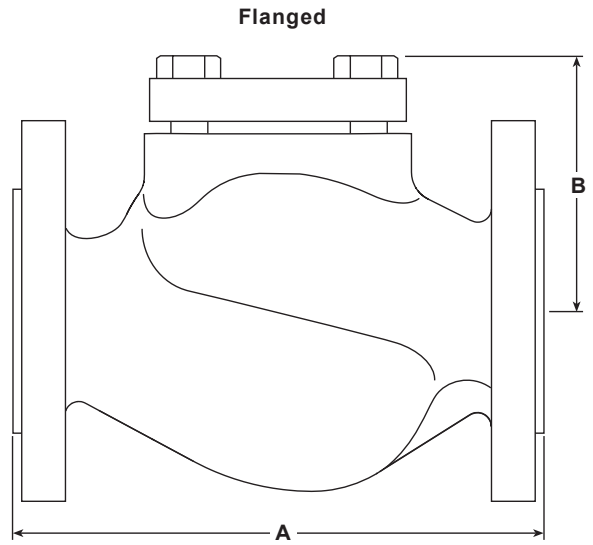
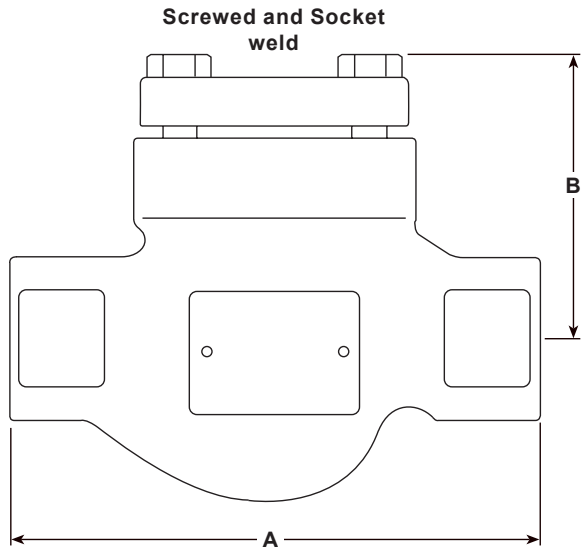

Dimension	Connection	Screwed	Flanged	Screwed	Flanged		Flanged
		BSP Socket weld	PN40 PN16 PN25 JIS 10/KS 10 JIS 20/KS 20	NPT	ASME 125 LCV3	LCV7	ASME 250 ASME 300
A	DN15 1/2"	130	130	6 1/2"	7 1/4"		7 1/2"
	DN20 3/4"	155	150	6 1/2"	7 1/4"		7 1/2"
	DN25 1"	160	160	7 3/4"	7 1/4"	7 1/4"	7 3/4"
	DN32 1 1/4"	185	180	8 1/2"			
	DN40 1 1/2"	205	200	9 1/4"	8 3/4"	8 3/4"	9 1/4"
	DN50 2"	230	230	10 1/2"	10"	10"	10 1/2"
	DN65 2 1/2"		290		10 1/2"	10 1/2"	11 1/2"
	DN80 3"		310		11 3/4"	11 3/4"	12 1/2"
DN100 4"		350		13 3/4"	13 3/4"	14 1/2"	
B	DN15 1/2"	88	88	4"	4"	4"	4"
	DN20 3/4"	88	88	4"	4"	4"	4"
	DN25 1"	88	88	4"	4"	4"	4"
	DN32 1 1/4"	117	117	5 3/16"			
	DN40 1 1/2"	117	117	5 3/16"	5 3/16"	5 3/16"	5 3/16"
	DN50 2"	117	117	5 3/16"	5 3/16"	5 3/16"	5 3/16"
	DN65 2 1/2"		166		7 7/8"	7 7/8"	7 7/8"
	DN80 3"		166		7 7/8"	7 7/8"	7 7/8"
DN100 4"		180		8 1/2"	8 1/2"	8 1/2"	

Capacities

Capacity	DN15 ½"	DN20 ¾"	DN25 1"	DN32 1¼"	DN40 1½"	DN50 2"	DN65 2½"	DN80 3"	DN100 4"
K _v	5	8.3	11	18	34	42	87	113	135

Opening pressures in mbar

Differential pressures with zero flow

Flow direction	DN15 to DN25	DN32 to DN50	DN65 to DN100
Horizontal	22.5	24.5	25.5
Vertical	20	20	20

Safety information, installation and maintenance

For full details see the Installation and Maintenance Instructions (IM-P029-17) supplied with the product.

Installation note:

Always install the lift check valve with the flow in the direction indicated on the body.

Disposal

These products are recyclable. No ecological hazard is anticipated with the disposal of these products, providing due care is taken.

How to order

Example: 1 off Spirax Sarco DN15 LCV4 lift check valve having flanged EN 1092 PN40 connections.

Spare parts

The spare parts available are shown in solid outline. Parts drawn in a grey line are not supplied as spares.

Available spares

LCV Gaskets kit (Cover gasket and seat gasket)	Spare 1
LCV Internals kit (Cover gasket, seat gasket, spring, disc and seat)	Spare 2



How to order spares

Always order spares by using the description given in the column headed 'Available spares' and state the size and type of trap. Always order spares by using the description of the LCV and Spare 1 or Spare 2.

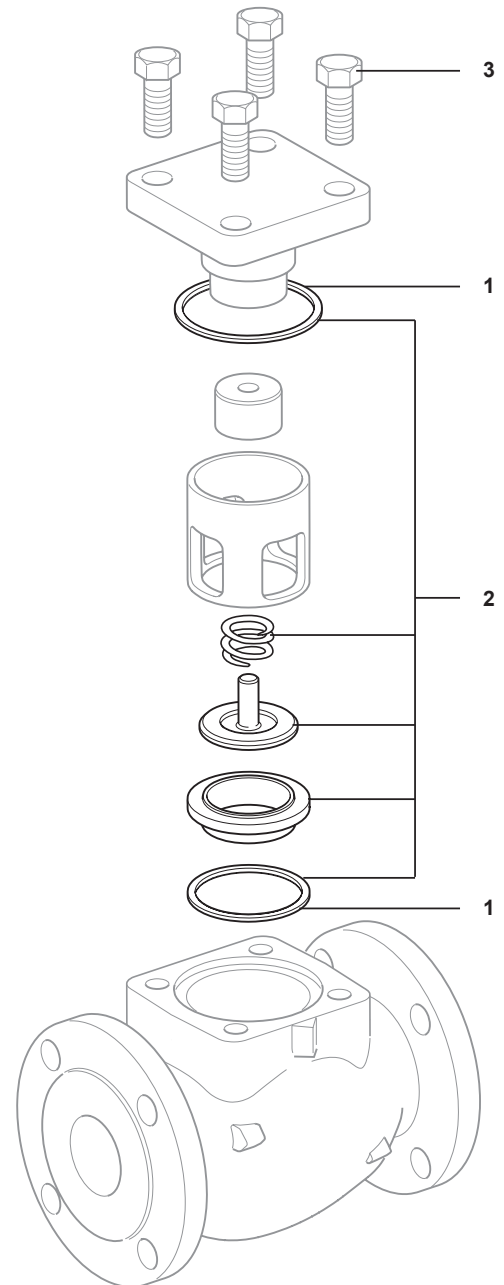
Example: 1 off LCV Internals kit – Spare 2, for a Spirax Sarco DN15 LCV4 lift check valve having flanged EN 1092 PN40 connections.



Recommended tightening torques

Item	Size					N m
		EN	ASME	EN	ASME	
	DN15 to DN25 (½" to 1")	LCV3 17 A/F	¾" A/F	LCV3 M10	½" - 13 UNC	40 - 50
		Others 19 A/F		Others M12		
3	DN32 to DN50 (1¼" to 2")	LCV3 19 A/F	1½" A/F	LCV3 M12	⅝" - 11 UNC	80 - 90
		Others 24 A/F		Others M16		
	DN65 to DN80 (2½" to 3")	24 A/F	1¼" A/F	M16	¾" - 9 UNC	90 - 100
	DN100 (4")	24 A/F	1½" A/F	M16	⅝" - 11 UNC	70 - 80