



TI-P504-15  
CH Issue 3



International Symbol

IL1M

Monnier

## International Compressed Air Lubricator

### Description

The IL1M Monnier international compressed air lubricator injects oil at a controlled rate into compressed air for the lubrication of pneumatic equipment.

### Principal features:

- Once set, compensates for varying air flowrates.
- Oil injected to give maximum atomisation.
- Operates over a wide range of pressures and flowrates.
- Easy sensitive adjustment.
- Tamper-proof feature; prevents unauthorised adjustment.
- Polycarbonate bowl.
- Polycarbonate or metal bowl.
- Easy fit metal bowl guard available.
- Internal and external black anodised finish.
- Metal bowl, option of sight level.

### Tamper-proof feature

As standard, each lubricator is supplied with a  $\frac{3}{16}$ " diameter tamper-proof ball that may be pressed or tapped into the top of the sight dome adjustment area after the oil rate has been set (See 'Principle of operation', page 3). This prevents any further adjustment by unauthorized personnel.

### Optional extras

For further technical information regarding the following options see page 2:

- Metal bowl.
- Stainless steel bowl guard.

### Sizes and pipe connections

$\frac{1}{4}$ ",  $\frac{3}{8}$ " and  $\frac{1}{2}$ " screwed BSP (BS 21-Rp).

### Operating limits

|                             |                    |          |
|-----------------------------|--------------------|----------|
| Maximum working pressure    | Polycarbonate bowl | 10 bar g |
|                             | Metal bowl         | 17 bar g |
| Maximum working temperature | Polycarbonate bowl | 50 °C    |
|                             | Metal bowl         | 70 °C    |



### Materials

| Part                        | Material                                  |
|-----------------------------|---|
| Head                        | Aluminium                                 |
| Bowl                        | Polycarbonate or Aluminium (Epoxy coated) |
| Seal                        | Nitrile rubber                            |
| Capacity valve              | Acetal                                    |
| Bowl guard (optional extra) | Stainless steel                           |

## Optional extras

**Metal bowl** with sight level



**Bowl guard**



In the interest of safety Spirax Sarco recommend that a bowl guard should be fitted to polycarbonate bowls - see the 'Warning' under 'Safety information, installation and maintenance'.

## Dimensions, capacity and weight

(approximate) in mm, ml and kg

**Polycarbonate bowl**

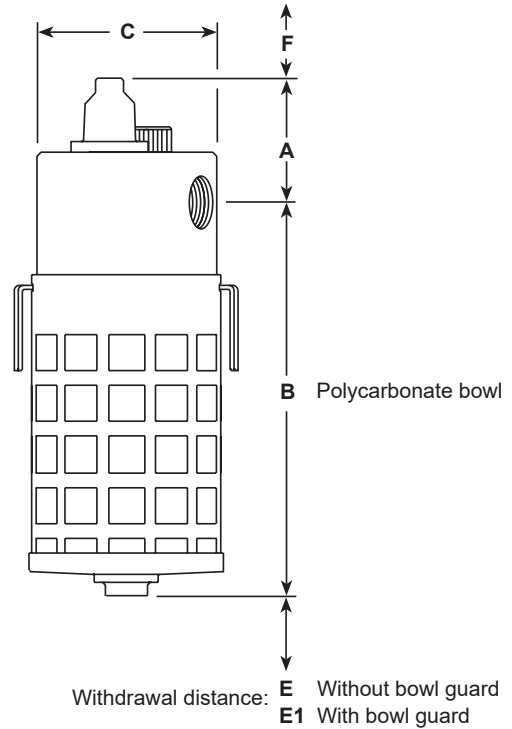

## Capacities - For all sizes

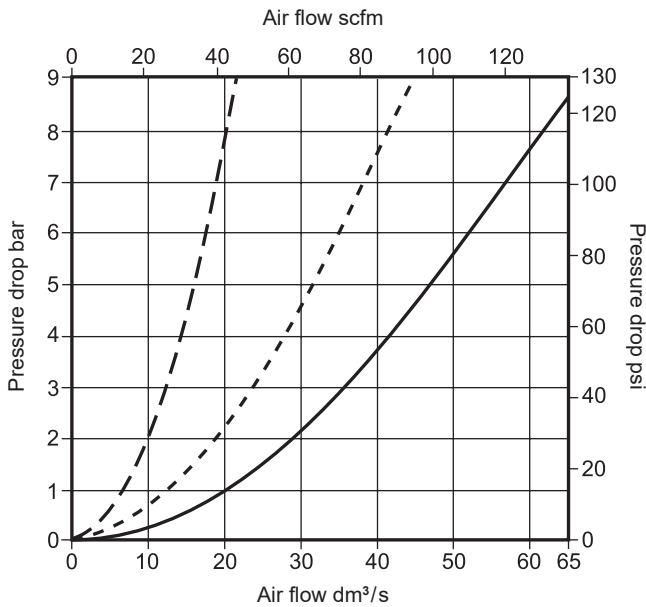

- 1/4" Maximum recommended flow
- 3/8" Maximum recommended flow
- 1/2" Maximum recommended flow

| A  | B   | C  | E  | E1 | F  | Bowl capacity | Weight Poly bowl | Weight With bowl guard |
|----|-----|----|----|----|----|---------------|------------------|------------------------|
| 43 | 138 | 64 | 30 | 82 | 16 | 150           | 0.432            | 0.508                  |

**Metal bowl**

| A             | B   | C      | E  | F  |
|---------------|-----|--------|----|----|
| 43            | 138 | 64     | 30 | 16 |
| Bowl capacity |     | Weight |    |    |
| 0.150         |     | 0.593  |    |    |

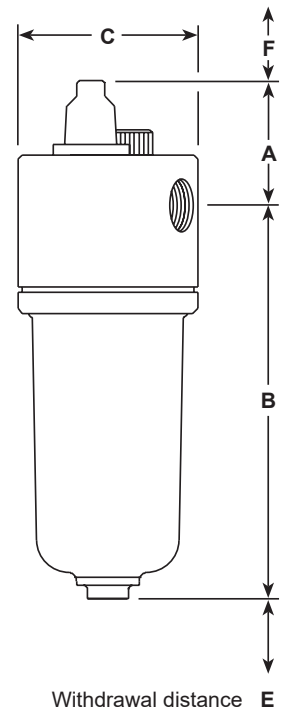

## Principle of operation

Monnier lubricators are used to maintain the proper ratio of oil and air and to maximize the performance and guarantee long life of pneumatic machinery.

Once the oil rate has been set, a Monnier lubricator provides reliable automatic lubrication. The Monnier design ensures efficient and dependable performance.

The Monnier Venturi valve (1) automatically maintains the ratio of oil to air that the user selects. It assures lubrication even at the lowest possible air flow (see Capacities on page 2). By automatically increasing the air pressure behind the oil in the main reservoir (2) in proportion to the increased air flow, the Venturi valve provides the desired degree of lubrication regardless of air flowrate.

The Monnier sight dome (3) is moulded from transparent polycarbonate that can be viewed at a full 360°. It includes an adjustment screw (4) for setting the oil rate, and a sight-feed tube (5) where the oil can be visually measured, drop by drop.

As standard, each lubricator is supplied with a  $\frac{3}{16}$ " diameter tamper-proof ball (6) that may be pressed or tapped into the top of the sight dome adjustment area after the oil rate has been set. This prevents any further adjustment by unauthorized personnel.

The automatic air control valve allows you to fill the oil reservoir (2) while the unit is pressurised and without shutting down.

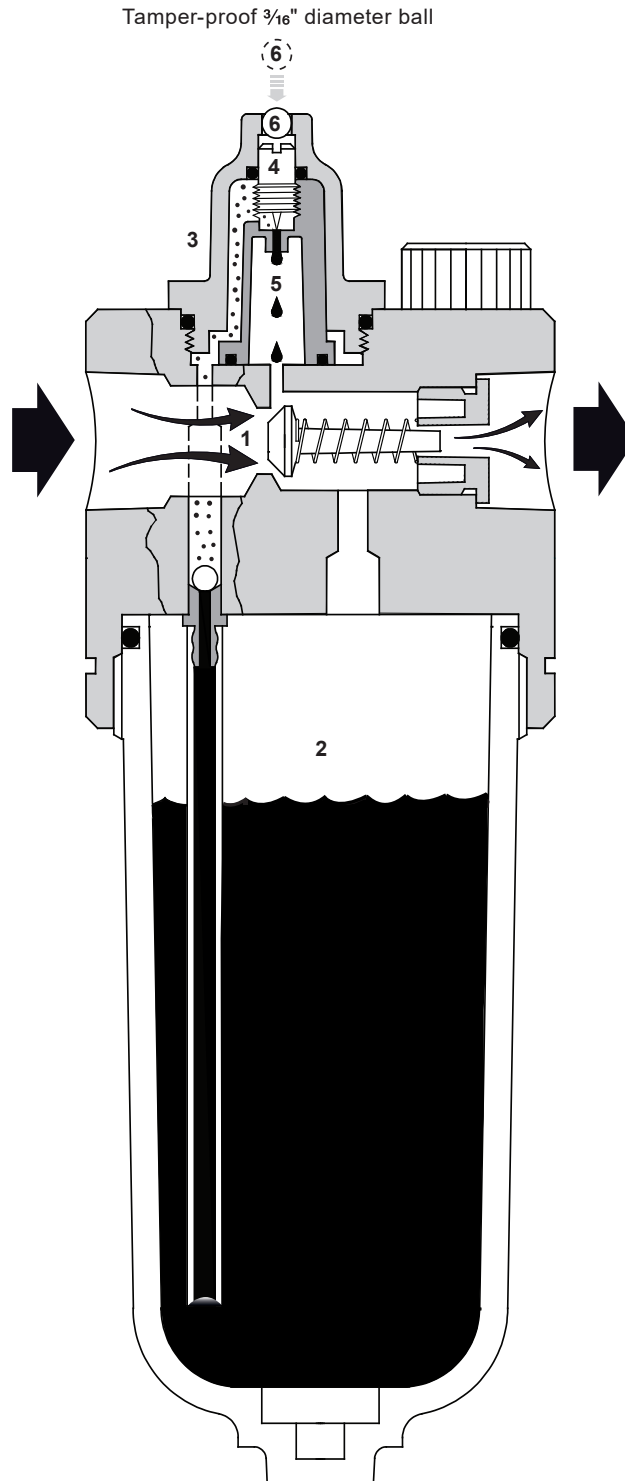

## Safety information, installation and maintenance

For full details see the Installation and Maintenance Instructions (IM-P504-16) supplied with the product.

### Warning:

Polycarbonate bowls are attacked by phosphate ester fluids, paint thinners and carbon tetrachloride. These and similar substances should never be allowed to come into contact with the bowl. Certain compressor lubricating oils also contain additives harmful to polycarbonate and, where there is any doubt, we recommend, in the interest of safety that a metal bowl or bowl guard be fitted.

### Lubricant:

The oil used must be compatible with the equipment being served by the lubricator and with the materials of construction of the lubricator itself. Generally the oil will be of the free fogging type in the viscosity rang of 7.5 to 64 centistokes (45 to 280 seconds Redwood No. 1) at 38 °F.

### Installation note:

Fit into a horizontal pipeline with the air flow in the direction of the arrow and bowl vertically downwards. The lubricator should be fitted as close as possible to the unit it is serving. A Monnier international filter (MF2M) should be fitted upstream to prevent any contaminants reaching the system to be lubricated.

### How to order

**Example:** 1 off IL1M Monnier international compressed air lubricator having a female ½" screwed BSP (BS 21 - Rp) connection.

**Note 1:** The product will be supplied with a polycarbonate bowl as standard. If a metal bowl is required (with or without sight level) it must be clearly specified on the order.

**Note 2:** If any optional extras are required, they must be clearly specified on the order.

## Spare parts

The spare parts available are detailed below. No other parts are supplied as spares.

### Available spares

|   |      |
|---|------|
| Bowl assembly state polycarbonate or metal<br>(with or without sight level) | A, B |
| Sight dome and filler plug assembly   | C, D |

### How to order spares

Always order spares by using the description given in the column headed 'Available spares' and state the size and type of unit.

**Example:** 1 off Polycarbonate bowl assembly for a ½" IL1M Monnier international compressed air lubricator.

