



# IJH

## Instantaneous Jet Heater

### Description

Direct contact heating of liquid is both efficient and instant. The range of heaters designed by Spirax Sarco has been developed to operate on most industrial applications where the direct introduction of steam into liquid is permissible. The units are designed to be silent in operation – a major advantage over conventional steam/liquid mixing.

### Advantages

- Simple operation
- No moving parts
- Minimal noise and vibration – normally associated with collapsing steam
- Very efficient

### Typical applications

- General process water heating
- Reactor jacket water heating
- Vegetable blanching
- Chemical heating
- Slurry heating
- Mining industry

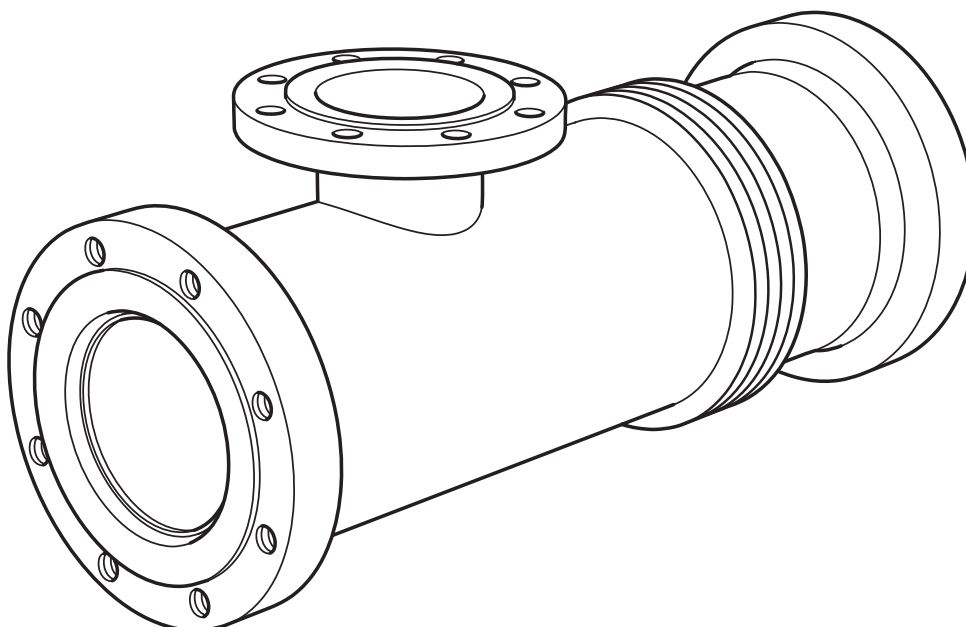

### Available types of IJH instantaneous jet heater

There are three types of instantaneous jet heater: Standard, Hygienic and Monobloc. They all behave the same but are suited to different applications.

<b>Standard</b>	Suitable for most applications ..... Can be sized using Spirax Sarco's Online Software
<b>Hygienic</b>	Can be supplied with any type of connection – on termination or body i.e. Sanitary clamp / RJT / IDF ..... Flanges and screwed connections maybe acceptable on the steam side – usually stipulated by the customer ..... Internal and external surfaces usually polished – to the customers' specification i.e. Sateen / Mirror / Dull – to eliminate small crevices ('bug' traps) ..... Limited to 6 bar g D/S steam maximum (thin wall stainless 1.6 mm thick) ..... Contact Spirax Sarco for sizing
<b>Monobloc</b>	Small, cost effective units for low pressure duties with a design pressure maximum of 10 bar g ..... Available for unit sizes up to DN65 (2½") NB ..... Contact Spirax Sarco for sizing

### Spirax Sarco's online calculation software

We recommend the use of our online sizing software to design a suitable unit (available at [www.spiraxsarco.com](http://www.spiraxsarco.com) with password).

### How does an IJH work

Pressurised cold liquid is introduced to the IJH instantaneous jet heater and is immediately accelerated through the combining nozzle, resulting in a local pressure drop.

Pressurised steam enters the IJH and is discharged into the liquid at high velocity, via a number of jets around the combining tube. This method of combining steam and liquid prevents 'backing up' should the steam be under a much higher pressure than the liquid.

Both the sensible and latent heat of the steam is fully dissipated within the liquid, making **Spirax Sarco's IJH instantaneous jet heater very efficient.**

Spirax Sarco's IJH instantaneous jet heater are also designed to combine the two streams, **silently** and **instantaneously** to prevent undue noise and wear normally associated with steam 'collapse'.

### Typical application

The schematic below illustrates a typical full system.

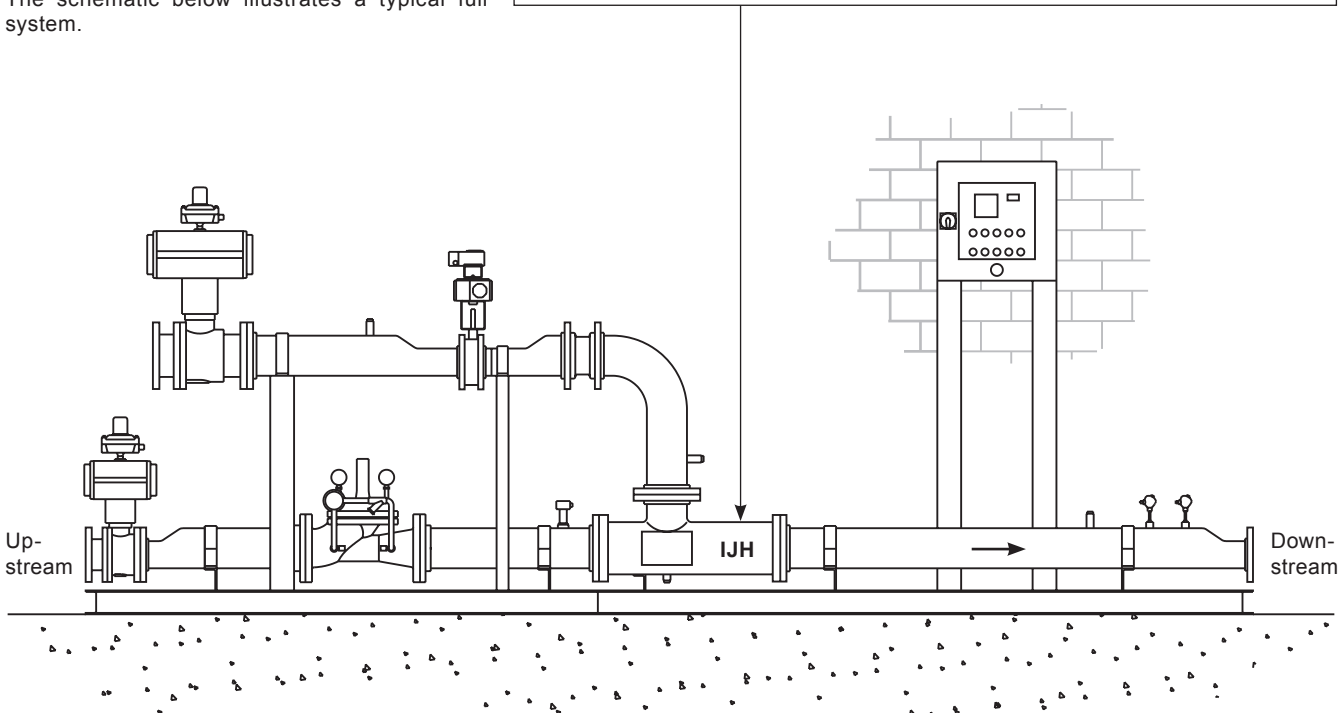
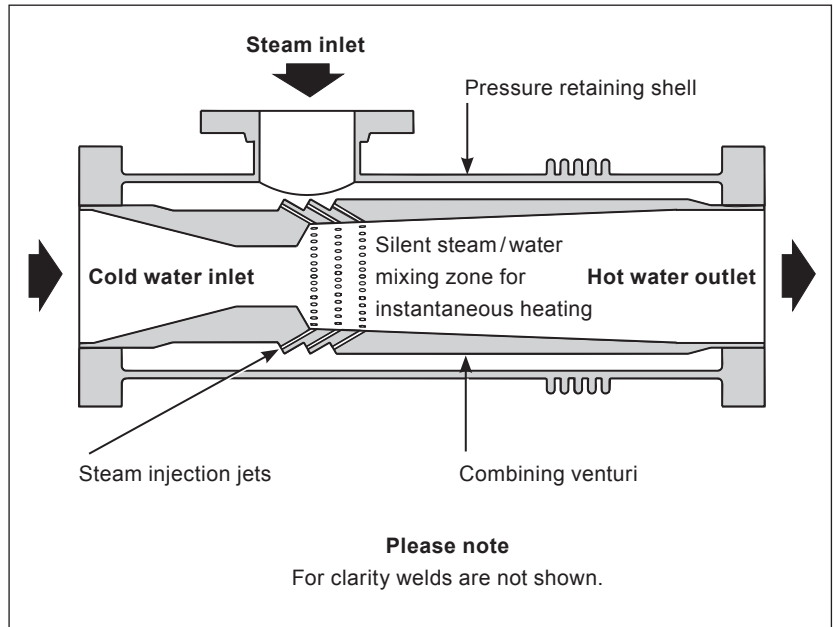

### Installation considerations

<b>Steam pipeline</b>	<b>Pipe run</b>	Ensure that the pipe run is flat along its bottom to ensure condensate does not collect in low points i.e. use eccentric not concentric reducers.
	<b>Main PRV pressure reducing valve</b>	It is recommended that the steam control valve be one or two pipe sizes below the main steam feedline to the IJH branch size - Use eccentric reducers.
	<b>Non return valve</b>	The non return valve should be situated adjacent to the IJH to prevent back flow of steam on failure of the cold water supply pressure.
<b>Water pipeline</b>	<b>Temperature probe</b>	It is recommended that the temperature probe be sited 6 to 10 pipe diameters downstream of the IJH.
	<b>Instruments</b>	Include suitable pressure gauge tapping points.
	<b>Drainage</b>	Drainage is important during shutdown always try to include a drainage facility on low points or ideally orientate the unit to be self-draining (discharge vertically up).

## Design considerations

The fluid to be heated is usually water; however when the liquid is not water the density and heat capacity of the fluid must be known.

### Liquid pressure drop

For most systems a 0.5 bar drop is considered reasonable; however the minimum pressure drop of 0.3 bar can be achieved. The pressure drop selected only occurs when no steam is flowing (on start-up or when no heating is required). During normal operation, the pressure drop is less as the steam gives the liquid a slight pressure 'boost'.

### Steam pressure

When designing a unit, the steam pressure at the inlet flange of the IJH must be adequate to overcome the liquid pressure.

If the steam pressure becomes lower than the liquid pressure the liquid could enter the steam line causing vibration. It is therefore important to consider the pressure drop across valves and equipment upstream of the IJH to ensure that the correct pressure at the steam inlet flange is maintained.

### Maximum liquid temperature

In general, the maximum temperature you can heat to is 5-10 °C below the saturation temperature of the liquid. When the liquid is heated beyond this temperature flashing can occur which can cause the unit to vibrate and become noisy.

However, if you want to calculate the maximum temperature, it can be calculated by the following method:

Saturation temperature = Steam pressure in the mixing zone x 0.85.

For example, if an IJH has a liquid-side inlet pressure of 2.5 bar g and the pressure drop is 0.5 bar, the pressure in the mixing zone is 2 bar g or 3.013 bar a.

$$0.85 \times 3.013 = 2.56 \text{ bar a}$$

$$T_{\text{sat}} @ 2.56 \text{ bar a} = 128.2 \text{ }^{\circ}\text{C}$$

$$\text{Maximum liquid temperature} = 128.2 \text{ }^{\circ}\text{C}$$

### Materials of construction

All of Spirax Sarco's IJH instantaneous jet heaters are designed and built to the customers specific criteria for their intended application to provide optimum performance and return on investment. We can also offer alternative materials for the Combining tube. In our experience the following three combinations of materials are the most popular:

- Carbon steel shell – Stainless steel internals
- Fully stainless steel
- Fully carbon steel
- Hastelloy

### Typical pipework velocities

- Steam feed velocities for all of our IJH instantaneous jet heaters are preferably sized for a maximum of 50 m/s (never > 65 m/s).

## Other considerations

### Distances

The recommended straight length distance downstream of the IJH before any bends, sensors or equipment is 6-10 pipe diameters. Please reference the typical application on page 2 which illustrates these recommended distances.

The pipework should always match the connection size of the unit. However if the pipework is a greater NB than the unit the pipework after the discharge flange should be a minimum of 6-10 pipe diameters length before returning to the pipework NB.

### Orientation of an IJH

The IJH can be installed and operated in almost any position but, the preferred orientation is to have the liquid flow horizontal with the steam branch on the top of the unit to help with drainage. However, we do not recommend that the unit be installed vertically with the flow downwards.

### Steam traps

If the steam supply is known to be wet or contains less than 5 °C of superheat, we strongly recommend the use of steam traps and separators in the pipeline. If the condensate is inadequately removed, the internals of the IJH will be subjected to conditions which will increase the wear rate, eventually resulting inefficient operation.

### Strainers

We strongly recommend the incorporation of strainers in both the steam pipeline and cold liquid pipeline. The strainer in the steam pipeline should be positioned upstream of any control valve and, the strainer in the liquid pipeline should be positioned upstream of the unit but, no closer than 6 pipe diameters from the liquid inlet flange.

### Connections

The IJH can be supplied with any type of connections on termination or body from flanged, screwed, sanitary clamp connections.

### Maintenance

Providing the steam used for heating is dry and saturated (or slightly superheated) an IJH needs little maintenance and should provide many years of service.

If, however, the liquid being heated is corrosive or abrasive, the steam is 'wet' or the unit is located within a harsh environment, the unit may need additional inspection. If it is determined that the IJH 'body' is in good condition but the internals are worn, you would need to evaluate its replacement or scope in its eventual replacement into the maintenance programme.

## Online calculation software

### Example

Water is to be heated from 18 °C at 2 bar g to 50 °C. The water flowrate is 282 m<sup>3</sup>/h and steam is available at 6 bar g 177 °C.

### Method

We can use Spirax Sarco's Online Sizing Software to design a suitable unit (available at [www.spiraxsarco.com](http://www.spiraxsarco.com) with password).

As the liquid to be heated is water, click 'water' as the liquid type and complete the following sections.

**NOTE: note that the heat capacity and density sections are blanked out. Water property data is automatically calculated by the program.**

When selecting the pressure drop across the unit the minimum is 0.3 bar and the maximum is 2 bar. 0.5 bar is usually acceptable and is the most common pressure drop to select.

If the steam is saturated click the saturated button, however as the steam is above the saturation temperature at 6 bar g enter the temperature into the field below.

Select an appropriate mechanical design conditions which must be greater than the operating conditions.

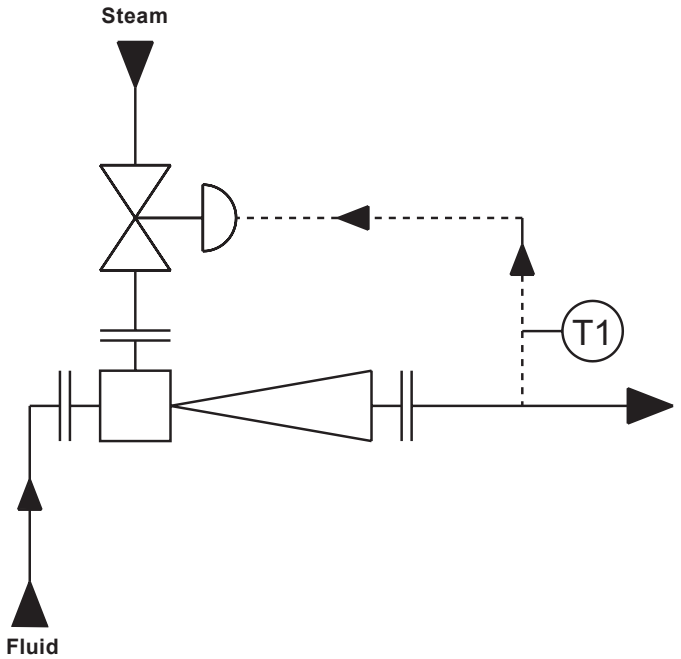

## IJH instantaneous jet heater quote

Welcome to the Online Quote system. Please complete the details below. If you are unsure how to use this program please use these instructions.

Client Reference	
Liquid Side Inlet Conditions	
Liquid Type	<input checked="" type="radio"/> Water <input type="radio"/> Other If other please enter description:
Pressure	2 bar(g)
Temp. In	18 °C
Flowrate	282 m <sup>3</sup> /h
Ht. Cap.	(will be calculated if liquid type is water) KJ/kg °C
C.W. Density	(will be calculated if liquid type is water) kg/CuM
Liquid Side	
Pressure Drop	0.5 Bar
Shell Materials of Construction	Carbon Steel
Internals Mat. of Construction	Carbon Steel
Steam Side Inlet Conditions	
Pressure	6 bar(g)
Temp. In	<input checked="" type="radio"/> Enter Temp <input type="radio"/> Saturated 177 °C
Liquid Side Outlet Conditions	
Temperature	50 °C
Mechanical Design Conditions	
Pressure	10 bar(g)
Temperature	200 °C

Calculate >

Please note that you can increase the unit size to your specification if required. You cannot reduce the unit size this way. The only way to reduce the size of the unit is by increasing the pressure drop across the unit. To do this click the 'Go Back' button and increase the pressure drop from 0.5 until the liquid side size reduces. The steam branch size is fixed and cannot be reduced.

## Design summary page

When the calculation button is pressed, the software will calculate the required Steam flowrate and the unit connection sizes. The user will see a summary screen, at which point the desired flange rating can be selected and then the 'Save & Email' button can be pressed - A Datasheet and GA Drawing, pages 5 and 6, will then be sent to your chosen email address.

## Design summary

Here is a summary of the design you have requested.

Liquid Side Conditions	
Liquid Type	Water
Inlet Temperature	18 Deg C
Outlet Temperature	50 Deg C
Inlet Pressure	2 Bar(g)
Outlet Pressure	1.5 Bar(g)
Flowrate	282 m <sup>3</sup> /h
Ht. Cap.	4.1857 KJ/Kg Deg C
C.W. Density	998.5955 kg/CuM
Liquid Side	
Pressure Drop	0.5 Bar
Shell Materials of Construction	Carbon Steel
Internals Mat. of Construction	Carbon Steel
Steam Conditions	
Pressure	6 Bar(g)
Temp. In	177 Deg C
Flowrate	14604 kg/hr
Mechanical Design Conditions	
Pressure	10 Bar(g)
Temperature	200 Deg C
Preferred Flange Rating	
Type	<input checked="" type="radio"/> Slip-On <input type="radio"/> Weld Neck
Rating	<input checked="" type="radio"/> 150 LB n/a PN10 <input type="radio"/> 300 LB <input type="radio"/> PN16 <input type="radio"/> 600 LB <input type="radio"/> PN25 <input type="radio"/> 900 LB <input type="radio"/> PN40 <input type="radio"/> 1500 LB <input type="radio"/> PN63 <input type="radio"/> 2500 LB
Unit Size	
Liquid Inlet/Outlet Size	10 "NB
Steam Branch Size	8 "NB
<p>&lt; Go Back Save &amp; E-mail &gt; Cancel</p>	

If you choose Save & E-mail the quote will be sent to your registered customer email address and you will be given a quote reference number in the event of any queries.

## Datasheet generated by the online software program

A typical example is illustrated below:

Spirax Sarco IJH Instantaneous Jet Heater Datasheet						
1	Client:	Spirax-Sarco Limited			Client Project Ref:	
2	Client's Ref:	EXAMPLE			Plant Location:	
3	Spirax Ref:	EXAMPLE/IJH00545			Nameplate Tag No.	
4	Description:				No. OFF:	1
5	Unit Ref:	IJH250CS6F0			Operation:	
6	Drawing No:	DEIJH00545-1			Service:	
7	Serial No:					
8	Unit Size:	10				
9	<b>PERFORMANCE OF ONE UNIT</b>					
10	Fluid to be Heated:	-	Water			
11	Density:	(Kg/M <sup>3</sup> )	998.6			
12	Heat Capacity:	(KJ/kg °C)	4.186			
13						
14	<b>Liquid Side Conditions:-</b>		<b>Max</b>			
15	Flowrate	(M <sup>3</sup> /hr)	282			
16	Inlet Temperature	( °C)	18			
17	Outlet Temperature	( °C)	50			
18	Inlet Pressure	(bar g)	2			
19	Pressure Drop	(bar)	0.5			
20						
21	<b>Steam Conditions:-</b>		<b>Max</b>			
22	Flowrate	(kg/h)	14603.1			
23	Pressure	(bar g)	6			
24	Temperature	( °C)	117			
25	<b>Notes</b>					
26						
27						
28	<b>MATERIALS OF CONSTRUCTION</b>					
29	Shell	Carbon Steel			Flanges	Carbon Steel
30	Combining Tube	Carbon Steel			Gaskets	TSL to Select
31	<b>Notes</b>					
32						
33						
34	<b>MECHANICAL DESIGN</b>			<b>CONNECTION DETAILS</b>		
35	Max. Design Pressure	(bar g)	10		Size ("NB)	Rating
36	Max. Design Temperature	( °C)	200	Liquid Inlet	10	150 LB
37	Internal Corrosion Allowance	(mm)	1.5	Liquid Outlet	10	150 LB
38	Mechanical Design Code	-	ASME B31.3	Steam Inlet	8	150 LB
39	Welding Standard	-	To Code	Tapping	0.5	BSP
40	CE Marking Required		TSL to determine	Flange Type	ASME B16.5 Slip-On	
41	External Surface Finish	-	High Temp. Silicone Aluminium	<b>Notes</b>		
42	Weight	(kg)	TBC			

### Selection example:

A Spirax Sarco Size 10 IJH instantaneous jet heater has been selected. The required steam flowrate is 14,603 kg/h.

**GA Drawing generated by the online software program**

A typical example of the drawing created with approximate dimensions and connections is also emailed to you - See below:

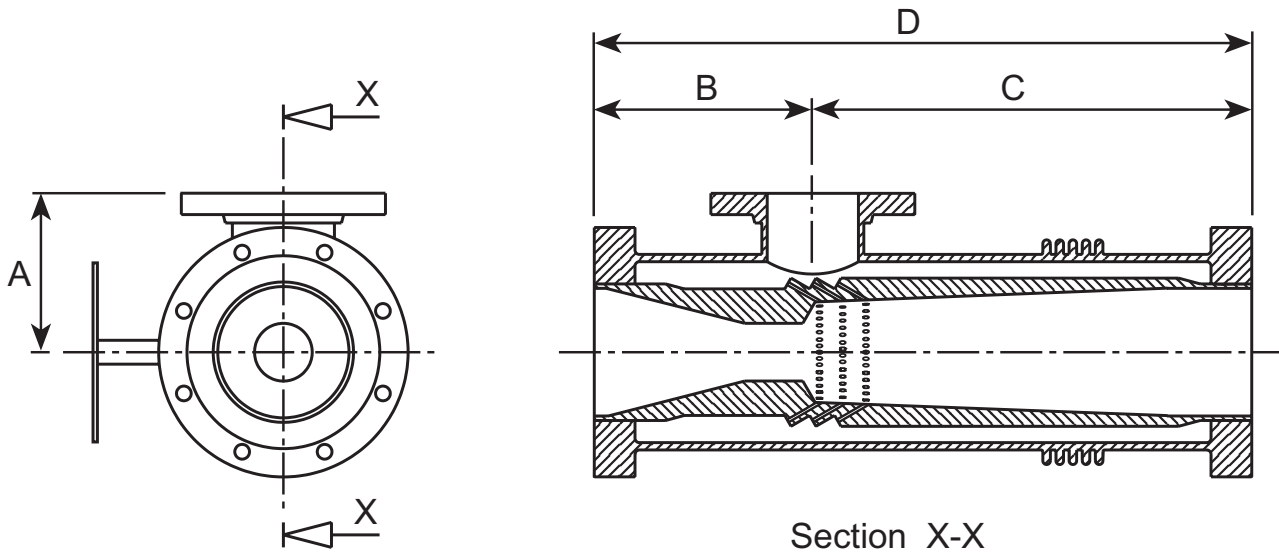

General assembly detail  
DN150 IJH Instantaneous Jet Heater

<b>Materials</b>	
Body:	Carbon steel
Internals:	Carbon steel
<b>Dimensions</b>	
A	254
B	245
C	492
D	737
<b>Connections</b>	
Water inlet	6 NB
Water outlet	6 NB
Steam inlet	4 NB
Flange type	Slip on
Flange rating	ASME B16.5 Class 150

**How to order**

**Example:** 1 off Spirax Sarco Size 10 IJH250CS instantaneous jet heater having ASME 150 RF slip-on flange connections.

**Note:** Attach the IJH Datasheet to the order.