



## IBV Series Z Alloy Steel Inverted Bucket Vertical Steam Trap

### Description

The IBV series Z inverted bucket steam trap is manufactured using alloy steel for the body and cover; with internal components being made of stainless steel. It is suitable for use with saturated and superheated steam and in high pressure and high temperature applications. The IBV is fully automatic and has been designed in such a way that there is minimal friction from mechanism movement; valve closure is immediate, without any steam loss and the discharge action is positive with no equivocal phases. The standard version will be supplied with bolted support brackets.

**On the cover of the IBV** there is a  $\frac{3}{8}$ " hole, threaded and plugged, to eliminate any water discharge after being hydraulically tested before leaving the factory. This hole can be reopened on site for the customer to perform periodic hydro testing.

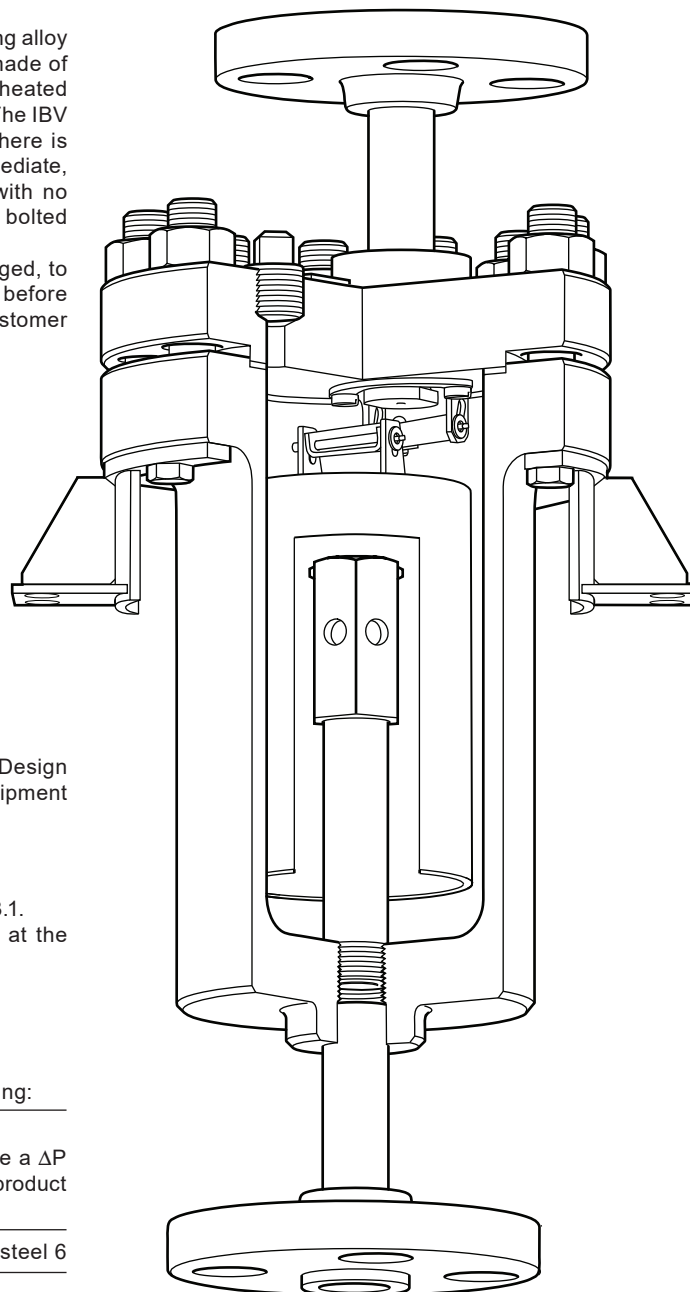

### Standards

This steam trap is designed following the ASME VIII Mechanical Design Code and complies with the requirements of the Pressure Equipment Directive and carries the  mark when so required.

### Certification

The product is available with material certification to EN 10204 3.1.

**Note:** All certification/inspection requirements must be stated at the time of order placement.

### Optional extras

On request the IBV steam trap can be equipped with the following:

#### An inbuilt stainless steel check valve

**Please note** that this option is only available for units that have a  $\Delta P$  maximum differential pressure of 40 bar and above - See the IBV product nomenclature and selection guide on page 12 for clarification.

#### A Stellite plug and seat

Alloy steel 6

## Available types

<b>Series C</b>	<b>Carbon steel</b> body and cover	<b>See</b> TI-P067-10
<b>Series C-LF2</b>	<b>Carbon steel</b> body and cover with a material specification of <b>A350 LF2</b> for low temperature applications down to -46 °C	<b>See</b> TI-P067-13
<b>Series Z</b>	<b>Alloy steel</b> body and cover	

## Sizes and pipe connections

**Please note** that all standard flanges (as noted below) will be slip-on type. Weld-neck type flanges can be supplied to special order and must be specified at the time of order placement.

1/2", 3/4", 1", 1 1/2", 2" and 3"

Screwed BSP or NPT

Socket weld, according to ASME B 16.11

1/2", 3/4", 1", 1 1/2", 2" and 3"

Flanged ASME B 16.5 ASME Class 150, 300, 600 and 900

DN15, DN20, DN25, DN40, DN50 and DN80

Flanged EN 1092 PN16, PN25, PN40, PN63 and PN100

## Materials

No.	Part	Material	
1	Body	Alloy steel	PED ASTM A182 F22 CL.3
2	Cover	Alloy steel	ASTM A182 F11
	Cover bolts	Alloy Steel	ASTM A193 B16
	Nuts		ASTM A194 GR. 7
3		(External parts only)	
	Nace version	Cover bolts	A479XM-19
		Nuts	A194 Gr. 8M
4	Cover gasket	Reinforced graphite	
5	Channelling pipe	Stainless steel	A335 P22
6	Bucket	Stainless steel	AISI 316
7	Bracket	Carbon Steel	A516 Gr. 70
8	Bracket screw	Stainless steel	AISI 316
9	Lever pin	Stainless steel	AISI 316
10	Split pin	Stainless steel	AISI 316
11	Valve seat	Stainless steel	400 series
12	Valve head	Stainless steel	400 series
13	Valve lever	Stainless steel	AISI 316

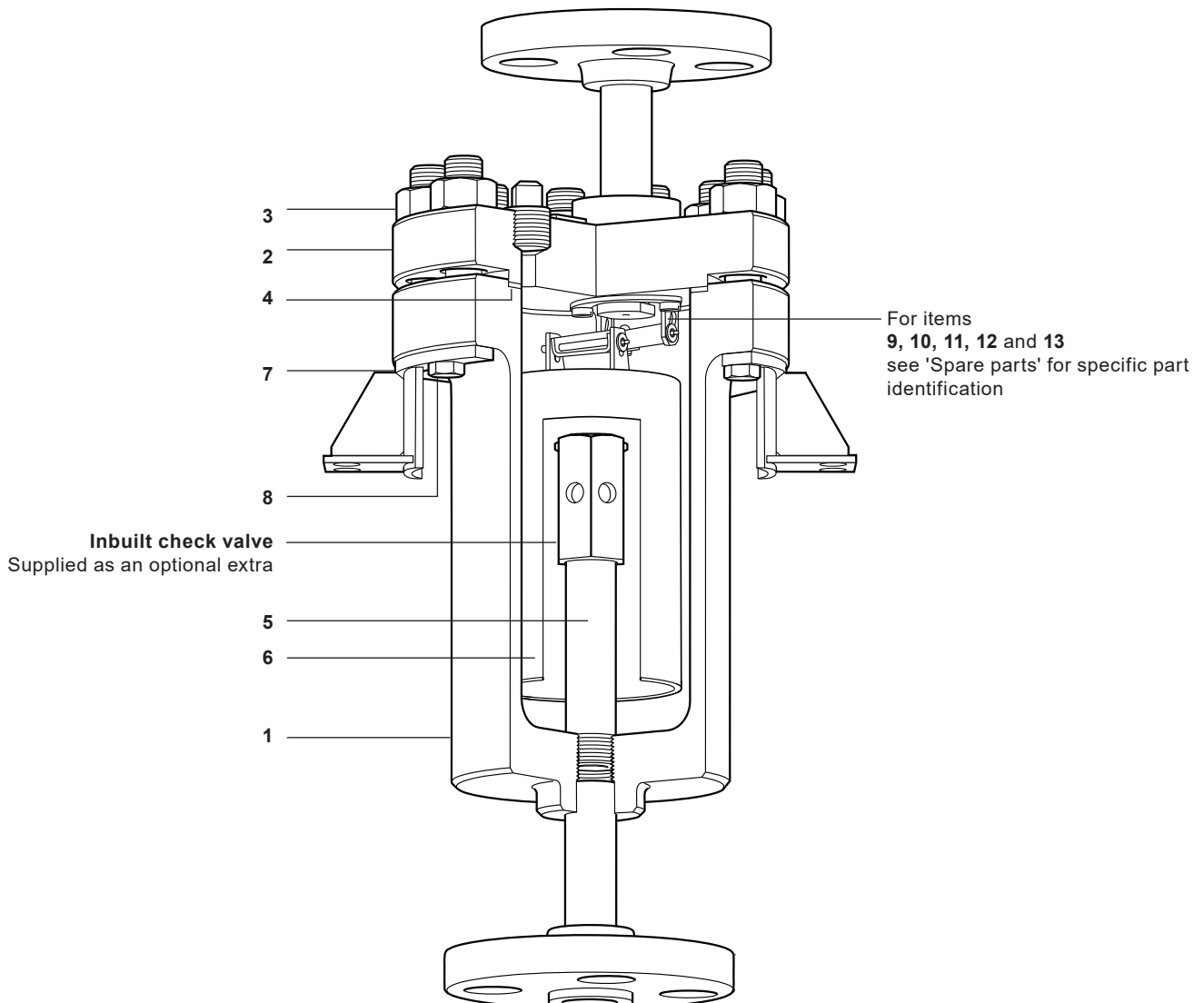

## Pressure/temperature limits (ISO 6552) - Screwed, Socket weld and Flanged ASME

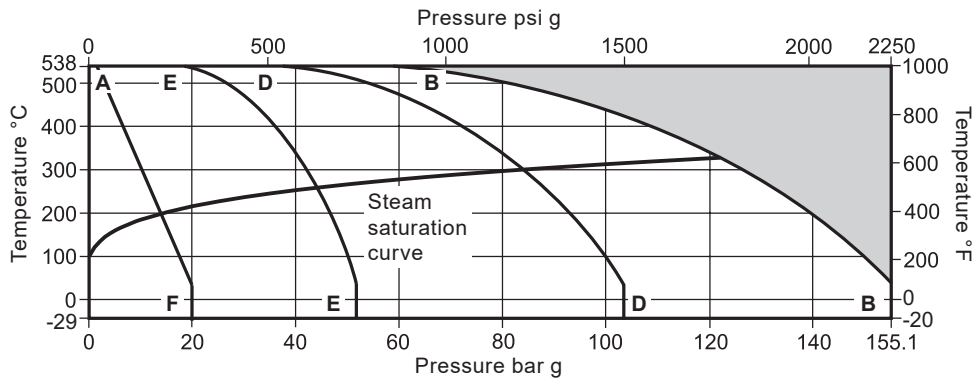

The product **must not** be used in this region or beyond the parameter of the PMA or TMA of the relative end connection.

\* **Please note** that the PMO is limited to the maximum  $\Delta P$  of the selected IBV.

Body design conditions		ASME Class 900	
A-B-B Screwed and Socket weld ASME Class 900	PMA - Maximum allowable pressure	155.1 bar g @ 38 °C	2250 psi g @ 100 °F
	TMA - Maximum allowable temperature	538 °C @ 55.3 bar g	1000 °F @ 800 psi g
	Minimum allowable temperature	-29 °C	-20 °F
	* PMO - Maximum operating pressure for saturated steam service	123 bar g @ 327 °C	1793 psi g
	TMO - Maximum operating temperature for saturated steam service	327 °C @ 123 bar g	622 °F @ 802 psi g
	Designed for a maximum cold hydraulic test pressure of:	232.6 bar g	3375 psi g
A-D-D ASME Class 600	PMA - Maximum allowable pressure	103.4 bar g @ 38 °C	1500 psi g @ 100 °F
	TMA - Maximum allowable temperature	538 °C @ 36.9 bar g	1000 °F @ 535 psi g
	Minimum allowable temperature	-29 °C	-20 °F
	* PMO - Maximum operating pressure for saturated steam service	85.6 bar g @ 300 °C	1241 psi g
	TMO - Maximum operating temperature for saturated steam service	300 °C @ 85.6 bar g	573 °F @ 535 psi g
	Designed for a maximum cold hydraulic test pressure of:	155.1 bar g	2250 psi g
A-E-E ASME Class 300	PMA - Maximum allowable pressure	51.7 bar g @ 38 °C	750 psi g @ 100 °F
	TMA - Maximum allowable temperature	538 °C @ 18.4 bar g	1000 °F @ 265 psi g
	Minimum allowable temperature	-29 °C	-20 °F
	* PMO - Maximum operating pressure for saturated steam service	45.6 bar g @ 259 °C	661 psi g
	TMO - Maximum operating temperature for saturated steam service	259 °C @ 45.6 bar g	499 °F @ 267 psi g
	Designed for a maximum cold hydraulic test pressure of:	77.5 bar g	1125 psi g
A-F-F ASME Class 150	PMA - Maximum allowable pressure	19.6 bar g @ 38 °C	290 psi g @ 100 °F
	TMA - Maximum allowable temperature	538 °C @ 1.4 bar g	1000 °F @ 20 psi g
	Minimum allowable temperature	-29 °C	-20 °F
	* PMO - Maximum operating pressure for saturated steam service	13.8 bar g @ 197 °C	200 psi g
	TMO - Maximum operating temperature for saturated steam service	197 °C @ 5.5 bar g	387 °F @ 80 psi g
	Designed for a maximum cold hydraulic test pressure of:	29.7 bar g	435 psi g

## Pressure/temperature limits (ISO 6552) - Flanged EN1092-1

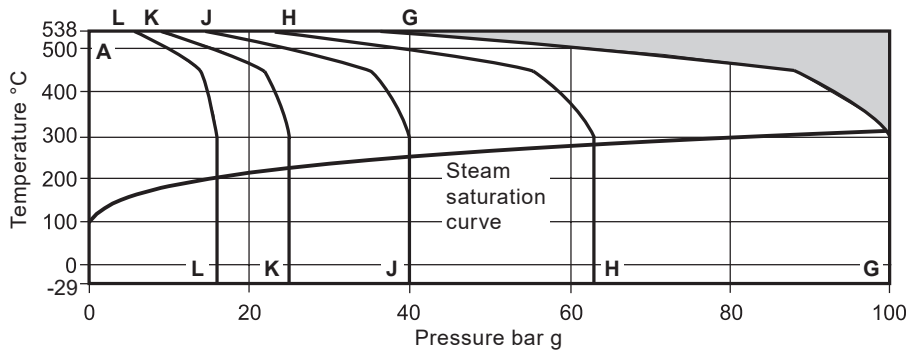

The product **must not** be used in this region or beyond the parameter of the PMA or TMA of the relative end connection.

\* **Please note** that the PMO is limited to the maximum  $\Delta P$  of the selected IBV.

Body design conditions		PN100	
A-G-G	PN100	PMA - Maximum allowable pressure	100 bar g @ 50 °C
		TMA - Maximum allowable temperature	538 °C @ 37.1 bar g
		Minimum allowable temperature	-29 °C
		* PMO - Maximum operating pressure for saturated steam service	99.4 bar g @ 311 °C
		TMO - Maximum operating temperature for saturated steam service	63 bar g @ 279 °C
		Designed for a maximum cold hydraulic test pressure of:	143 bar g
A-H-H	PN63	PMA - Maximum allowable pressure	63 bar g @ 50 °C
		TMA - Maximum allowable temperature	538 °C @ 23.4 bar g
		Minimum allowable temperature	-29 °C
		* PMO - Maximum operating pressure for saturated steam service	63 bar g @ 279 °C
		TMO - Maximum operating temperature for saturated steam service	279 °C @ 63 bar g
		Designed for a maximum cold hydraulic test pressure of:	90 bar g
A-J-J	PN40	PMA - Maximum allowable pressure	40 bar g @ 50 °C
		TMA - Maximum allowable temperature	538 °C @ 14.8 bar g
		Minimum allowable temperature	-29 °C
		* PMO - Maximum operating pressure for saturated steam service	40 bar g @ 251 °C
		TMO - Maximum operating temperature for saturated steam service	251 °C @ 40 bar g
		Designed for a maximum cold hydraulic test pressure of:	57.2 bar g
A-K-K	PN25	PMA - Maximum allowable pressure	25 bar g @ 50 °C
		Minimum allowable temperature	-29 °C
		* PMO - Maximum operating pressure for saturated steam service	25 bar g @ 226 °C
		TMO - Maximum operating temperature for saturated steam service	226 °C @ 25 bar g
		Designed for a maximum cold hydraulic test pressure of:	35.7 bar g
		A-L-L	PN16
TMA - Maximum allowable temperature	538 °C @ 5.9 bar g		
Minimum allowable temperature	-29 °C		
* PMO - Maximum operating pressure for saturated steam service	16 bar g @ 204 °C		
TMO - Maximum operating temperature for saturated steam service	204 °C @ 16 bar g		
Designed for a maximum cold hydraulic test pressure of:	22.8 bar g		

## Capacities - DN15

**Note:** IBV inverted bucket steam traps should be selected for use at the most appropriate working differential pressure and not on the basis of load.

**Condensate discharge capacities (kg/h)** - The discharge capacities in the table are referring to the operating temperature of the saturated steam and the PMO of the steam trap shall be the relevant  $\Delta P$  maximum differential pressure of each specific model.

**For optimum trap selection you need to know the following criteria:**

- The hourly amount of condensate to be discharged, inclusive of the safety factor: x 1.5 for continuous use, x 2 to x 3 for intermittent use.
- The effective differential pressure.

### Working example:

Condensate discharge = 500 kg/h

Effective differential pressure = 30 bar

Upstream pressure = 45 bar g

Backpressure = 15 bar g

**The unit of choice** would have a  $\Delta P$  max. differential pressure of **70 bar** which is greater than the upstream pressure.

For full product selection and nomenclature follow the guide on page 13.

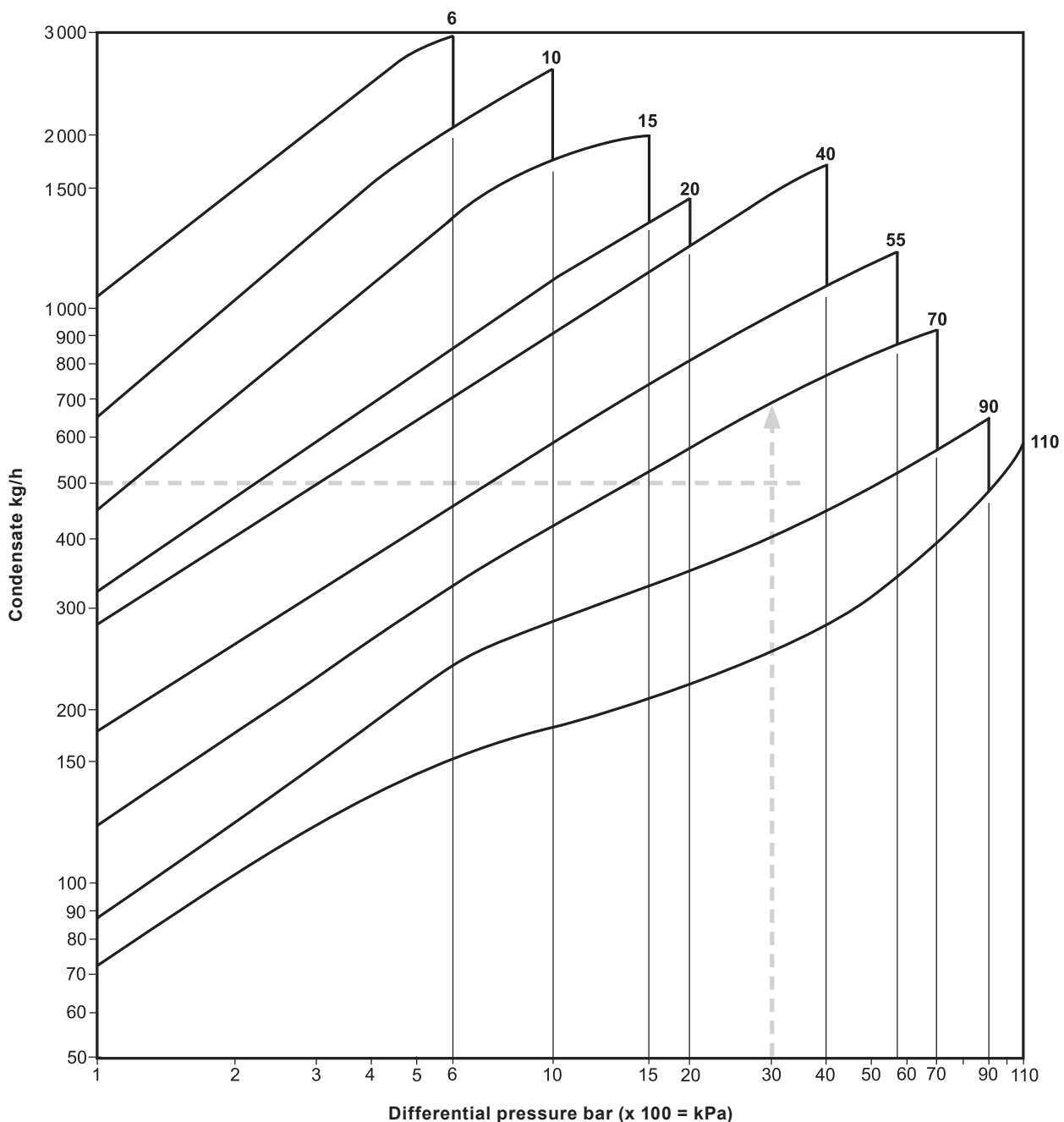

## Capacities - DN20

**Note:** IBV inverted bucket steam traps should be selected for use at the most appropriate working differential pressure and not on the basis of load.

**Condensate discharge capacities (kg/h)** - The discharge capacities in the table are referring to the operating temperature of the saturated steam and the PMO of the steam trap shall be the relevant  $\Delta P$  maximum differential pressure of each specific model.

**For optimum trap selection you need to know the following criteria:**

- The hourly amount of condensate to be discharged, inclusive of the safety factor: x 1.5 for continuous use, x 2 to x 3 for intermittent use.
- The effective differential pressure.

### Working example:

Condensate discharge = 1050 kg/h

Effective differential pressure = 30 bar

Upstream pressure = 45 bar g

Backpressure = 15 bar g

**The unit of choice** would have a  $\Delta P$  max. differential pressure of **55 bar** which is greater than the upstream pressure.

For full product selection and nomenclature follow the guide on page 13.

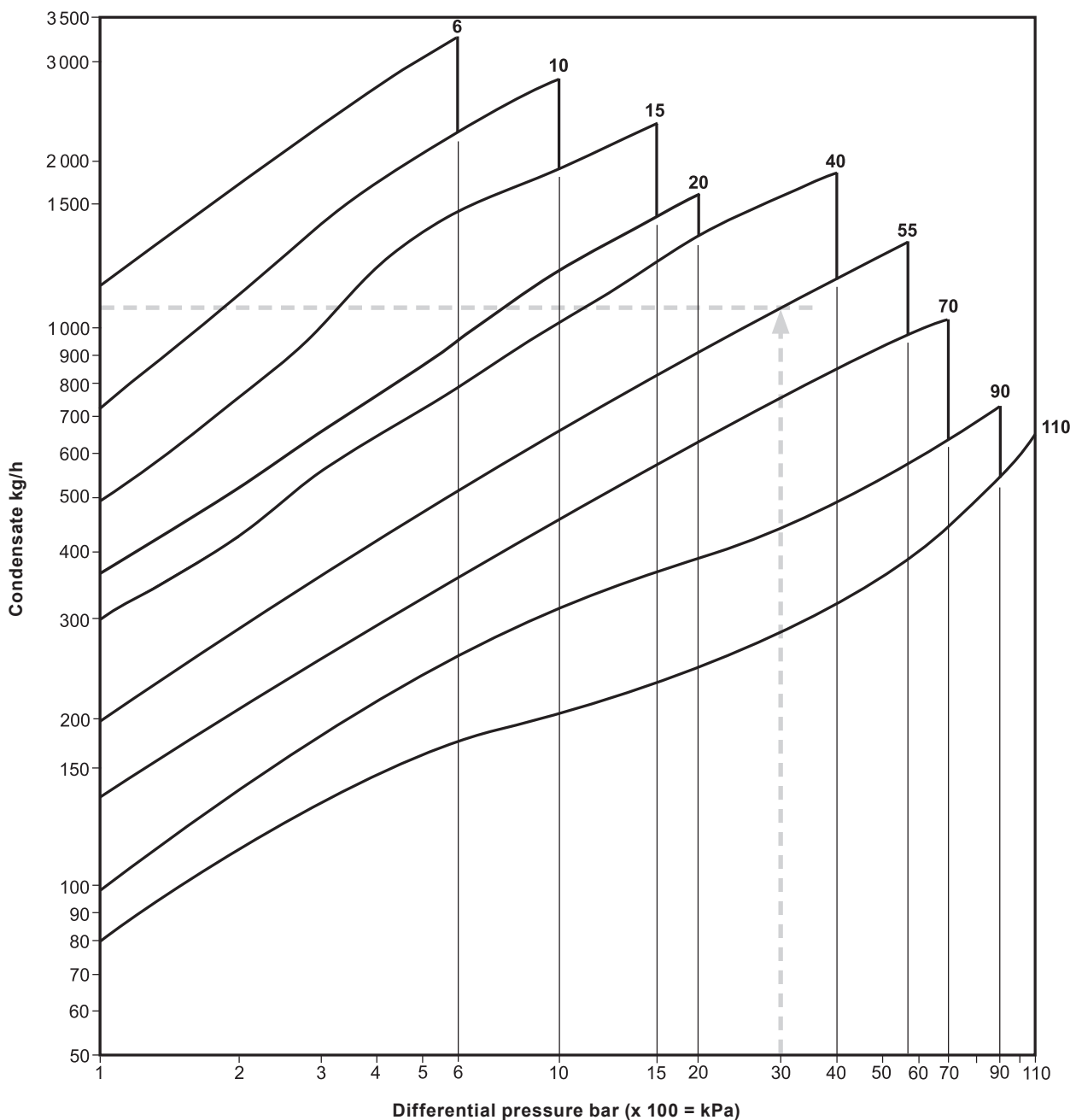

## Capacities - DN25

**Note:** IBV inverted bucket steam traps should be selected for use at the most appropriate working differential pressure and not on the basis of load.

**Condensate discharge capacities (kg/h)** - The discharge capacities in the table are referring to the operating temperature of the saturated steam and the PMO of the steam trap shall be the relevant  $\Delta P$  maximum differential pressure of each specific model.

**For optimum trap selection you need to know the following criteria:**

- a) The hourly amount of condensate to be discharged, inclusive of the safety factor: x 1.5 for continuous use, x 2 to x 3 for intermittent use.
- b) The effective differential pressure.

### Working example:

Condensate discharge = 2000 kg/h

Effective differential pressure = 4 bar

Upstream pressure = 5 bar g

Backpressure = 1 bar g

The unit of choice would have a  $\Delta P$  max. differential pressure of **15 bar** which is greater than the upstream pressure.

For full product selection and nomenclature follow the guide on page 13.

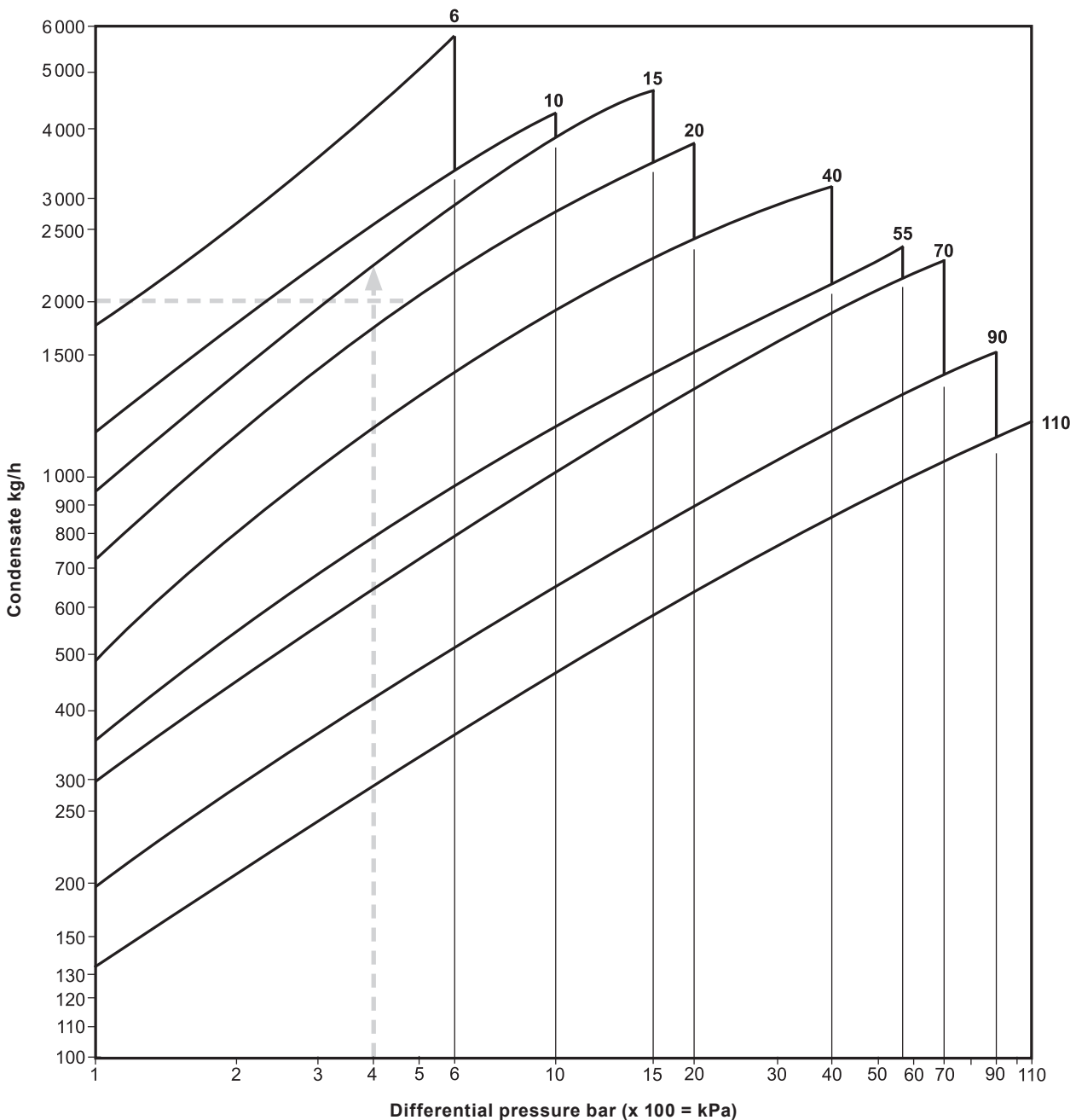



## Capacities - DN40

**Note:** IBV inverted bucket steam traps should be selected for use at the most appropriate working differential pressure and not on the basis of load.

**Condensate discharge capacities (kg/h)** - The discharge capacities in the table are referring to the operating temperature of the saturated steam and the PMO of the steam trap shall be the relevant  $\Delta P$  maximum differential pressure of each specific model.

**For optimum trap selection you need to know the following criteria:**

- a) The hourly amount of condensate to be discharged, inclusive of the safety factor: x 1.5 for continuous use, x 2 to x 3 for intermittent use.
- b) The effective differential pressure.

### Working example:

Condensate discharge = 2000 kg/h

Effective differential pressure = 50 bar

Upstream pressure = 75 bar g

Backpressure = 25 bar g

**The unit of choice** would have a  $\Delta P$  max. differential pressure of **110 bar** which is greater than the upstream pressure.

For full product selection and nomenclature follow the guide on page 13.

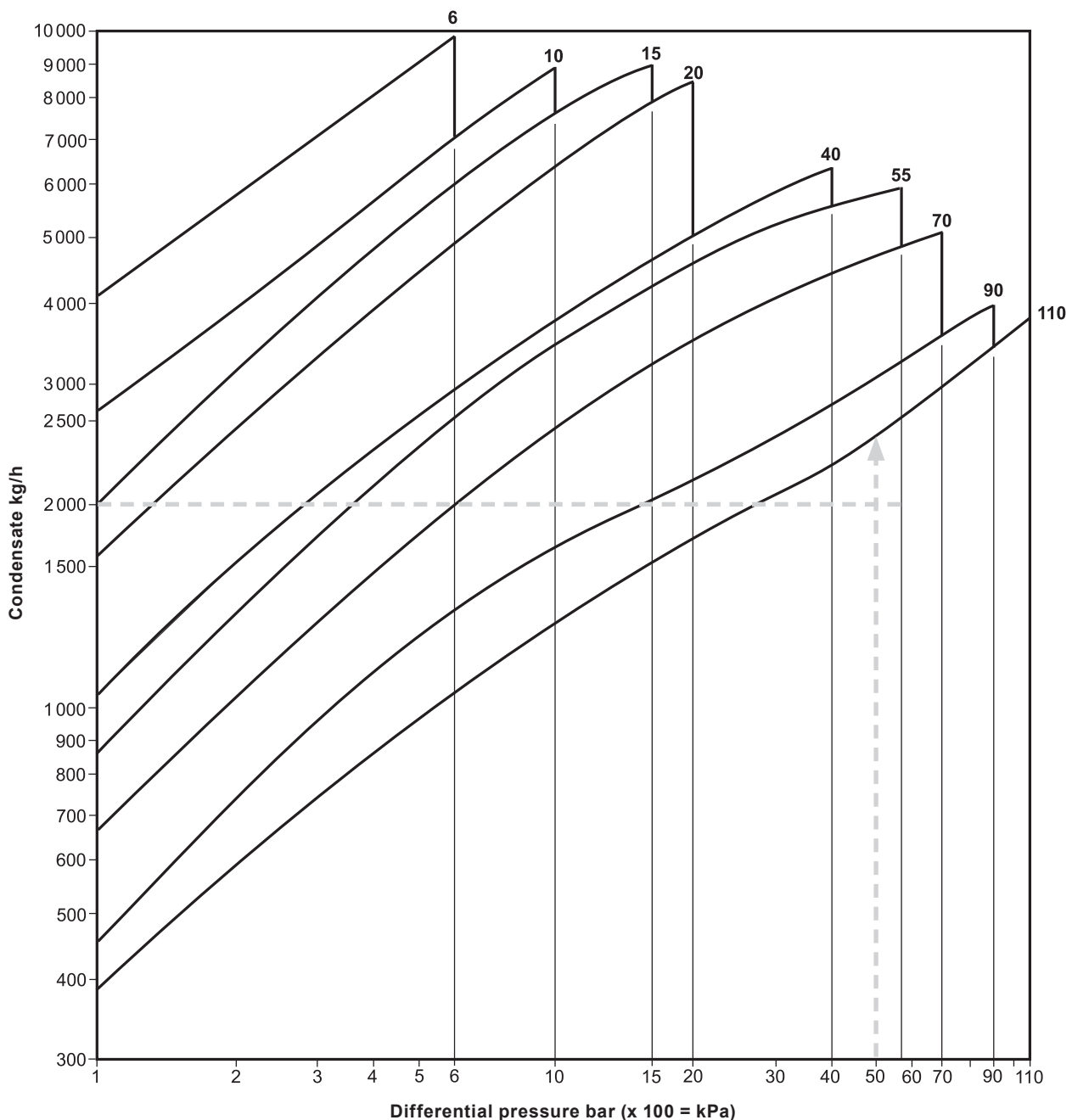

## Capacities - DN50

**Note:** IBV inverted bucket steam traps should be selected for use at the most appropriate working differential pressure and not on the basis of load.

**Condensate discharge capacities (kg/h)** - The discharge capacities in the table are referring to the operating temperature of the saturated steam and the PMO of the steam trap shall be the relevant  $\Delta P$  maximum differential pressure of each specific model.

**For optimum trap selection you need to know the following criteria:**

- The hourly amount of condensate to be discharged, inclusive of the safety factor: x 1.5 for continuous use, x 2 to x 3 for intermittent use.
- The effective differential pressure.

### Working example:

Condensate discharge = 6000 kg/h

Effective differential pressure = 8 bar

Upstream pressure = 10 bar g

Backpressure = 2 bar g

**The unit of choice** would have a  $\Delta P$  max. differential pressure of **20 bar** which is greater than the upstream pressure.

For full product selection and nomenclature follow the guide on page 13.

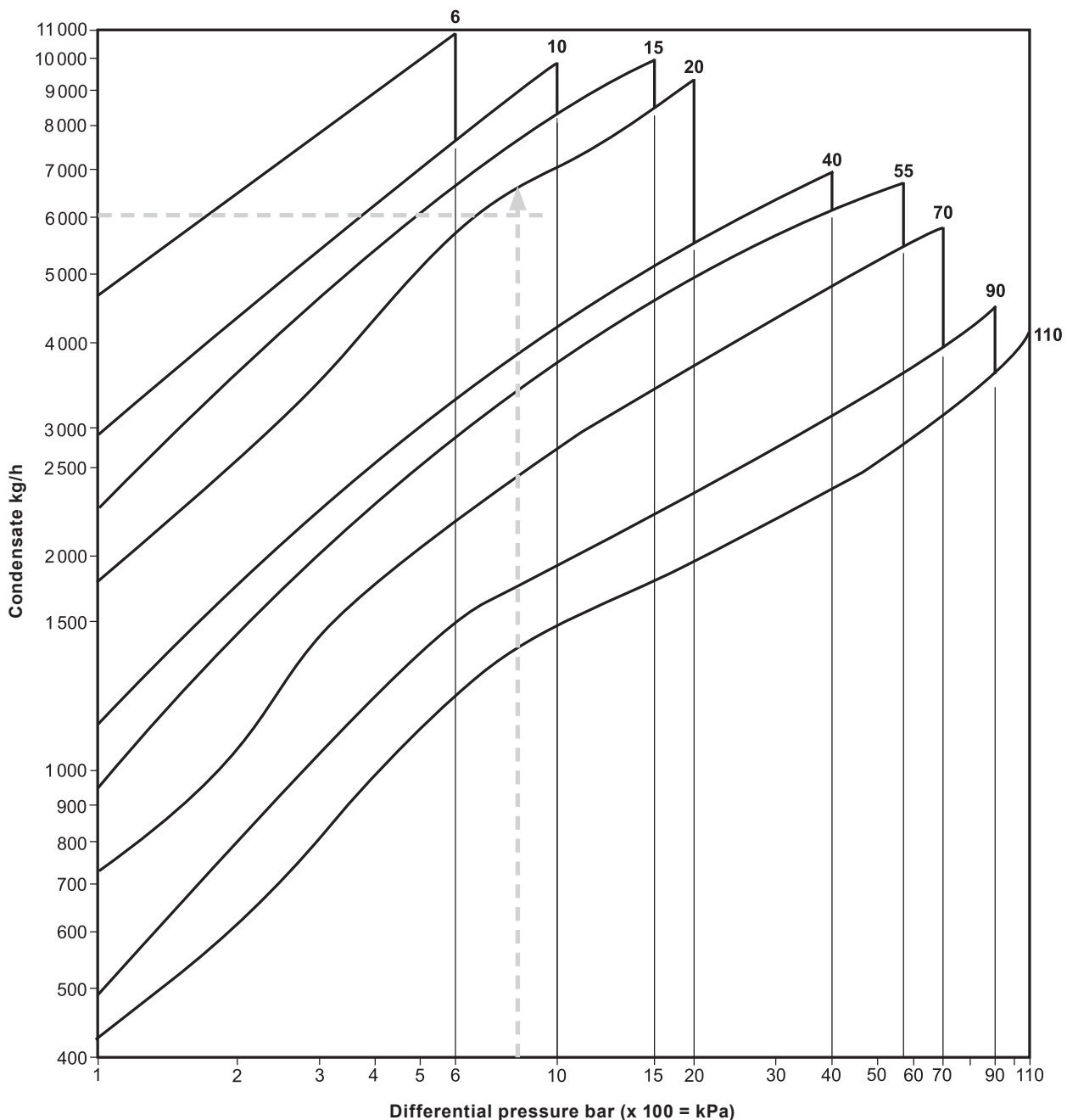

## Capacities - DN80

**Note:** IBV inverted bucket steam traps should be selected for use at the most appropriate working differential pressure and not on the basis of load.

**Condensate discharge capacities (kg/h)** - The discharge capacities in the table are referring to the operating temperature of the saturated steam and the PMO of the steam trap shall be the relevant  $\Delta P$  maximum differential pressure of each specific model.

**For optimum trap selection you need to know the following criteria:**

- a) The hourly amount of condensate to be discharged, inclusive of the safety factor: x 1.5 for continuous use, x 2 to x 3 for intermittent use.
- b) The effective differential pressure.

### Working example:

Condensate discharge = 5000 kg/h

Effective differential pressure = 30 bar

Upstream pressure = 55 bar g

Backpressure = 25 bar g

**The unit of choice** would have a  $\Delta P$  max. differential pressure of **90 bar** which is greater than the upstream pressure.

For full product selection and nomenclature follow the guide on page 13.

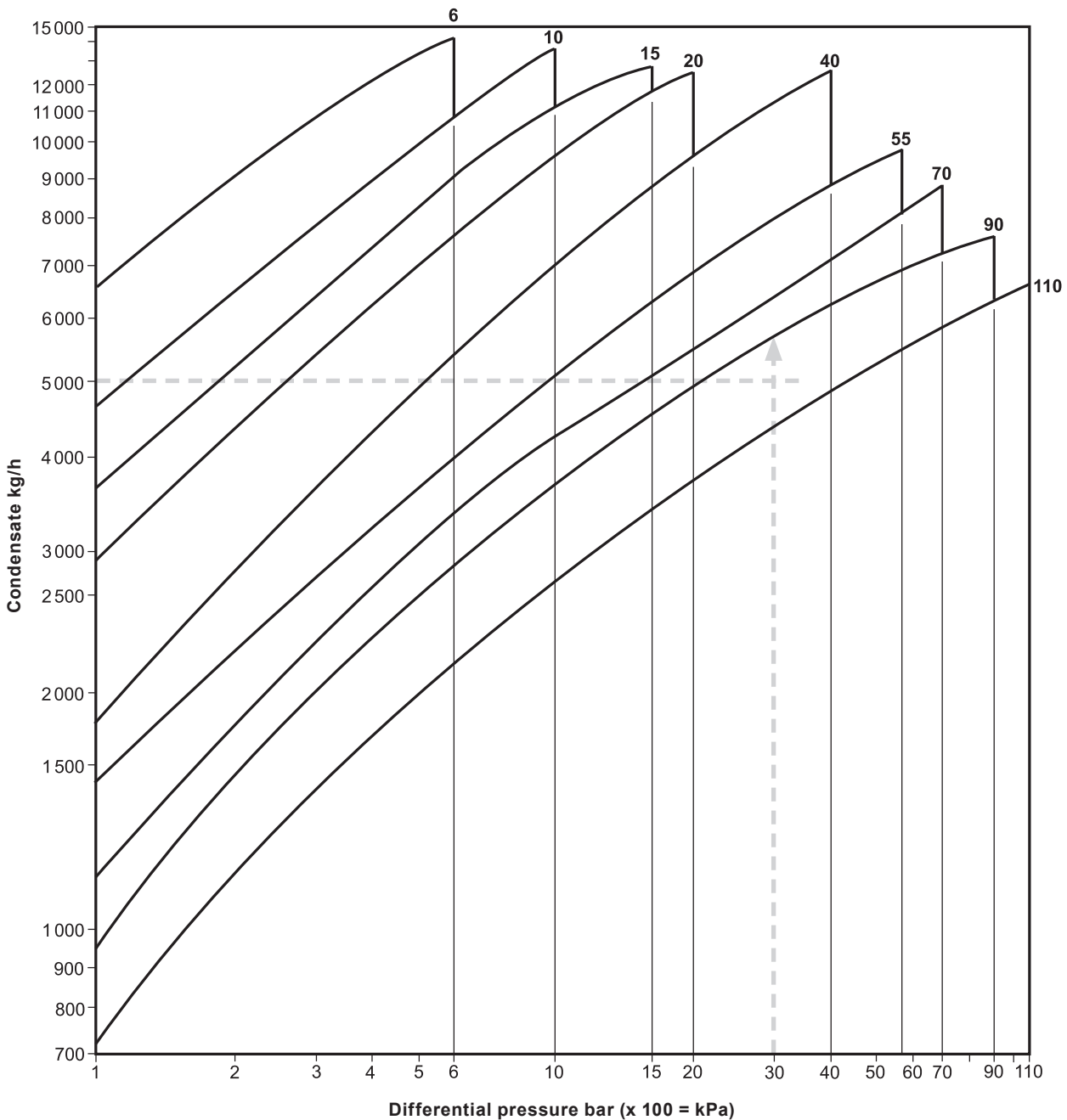

**Dimensions/weights (approximate) in mm and kg**

IBV size	Dimensions				
	A	B	C	D	E
DN15 1/2"	260	488	420	25	165
DN20 3/4"	260	488	420	25	165
DN25 1"	345	616	530	40	210
DN40 1 1/2"	411	774	650	39	265
DN50 2"	411	782	650	39	265
DN80 3"	532	1026	850	36	305

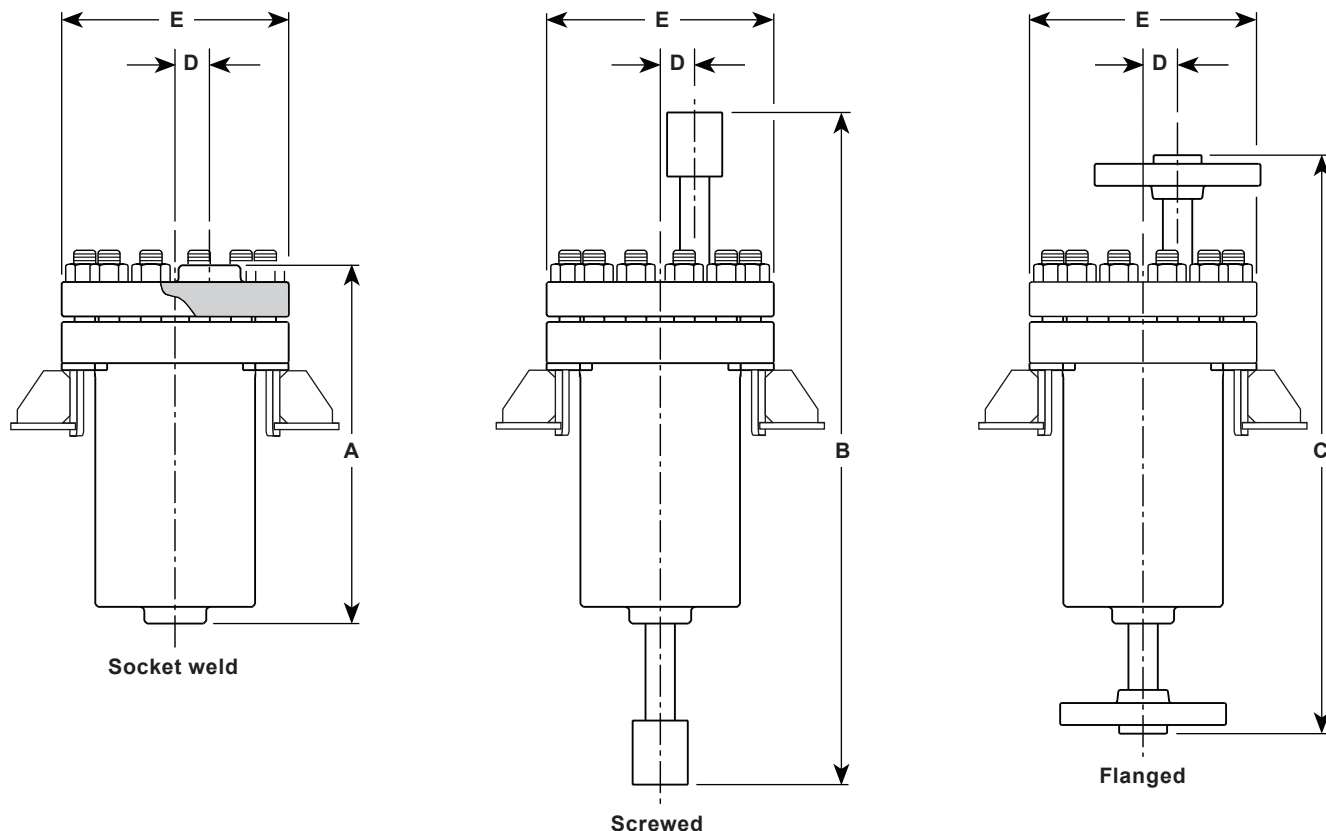

IBV size	Weights												
	BSP + NPT	Socket weld	Flanged ASME Class:					Flanged EN 1092:					
			150	300	600	900	1500*	PN16	PN25	PN40	PN63	PN100	PN160
DN15 1/2"	20	18	20	20	20	22	22	20	20	20	20	22	22
DN20 3/4"	26	24	26	28	28	30	30	28	28	28	28	30	30
DN25 1"	42	39	42	44	44	48	48	42	42	42	42	46	46
DN40 1 1/2"	68	65	70	72	72	78	78	70	70	70	70	74	74
DN50 2"	68	65	72	74	76	88	88	72	72	72	74	78	78
DN80 3"	125	120	132	136	138	152	162	130	130	130	134	138	142

\* on request

## IBV product nomenclature and selection guide:

Please note that other units are available on request to suit the specifics of a particular process application.

## IBV product nomenclature and selection guide:

Please note that other units are available on request to suit the specifics of a particular process application.

<b>Series</b>	Z = Alloy steel	Z
<b>PMO @ Saturated steam temperature for Alloy steel the body rating</b>	123 bar g = ASME Class 900 body	123
<b>ΔP maximum differential pressure</b>	ΔP = 6, 10, 15, 20, 40, 55, 70, 90, 110 bar	110
<b>Size</b>	1/2", 3/4", 1", 1 1/2", 2", 3" = or DN15, DN20, DN25, DN40, DN50, DN80	3"
<b>Connections</b>	<b>Screwed</b> = BSP or NPT	ASME Class 300
	<b>Socket weld</b> = According to ASME B 16.11	
	<b>Flanged</b> ASME = ASME Class 150, 300, 600, 900, (*1500 available on request) EN 1092 = PN16, PN25, PN40, PN63, PN100	
<b>Optional extras</b>	Blank = Standard	
	NACE = NACE compliancy	
	CV = Check valve <b>Please note</b> that this option is only available for units that have a ΔP maximum differential pressure of 40 bar and above - See above.	

IBV product selection example:

IBV	-	Z	-	123	-	110	-	3"	-	ASME Class 300	-	
-----	---	---	---	-----	---	-----	---	----	---	----------------	---	--

### How to order

1 off Spirax Sarco IBV-Z-123-110-3"-Flanged ASME Class 300 inverted bucket vertical steam trap having an alloy steel body and cover with stainless steel internals.

The following will be supplied, if specified, at the time of order placement:

1. A special name-plate when a U-STAMP has been specified.

## Safety information, installation and maintenance

For full details see the Installation and Maintenance Instructions supplied with the product.

### Installation note:

The trap must be installed below the drain point with the body upright in a vertical position, the cover at the top and the inlet connection at the bottom; this orientation will ensure that the bucket mechanism will rise and fall vertically without any friction. It is recommended that a strainer is installed upstream of the IBV to protect it from contamination.

To permit safe inspection for cleaning or maintenance purpose it is again recommended that suitable shut-off valves are installed upstream and downstream of the IBV application.

It needs to be appreciated that there is blast discharge with this device, consequently the downstream accessories, if any, should be installed at a minimum distance of 1 m from the IBV.

### Disposal

This product is recyclable. No ecological hazard is anticipated with the disposal of this product providing due care is taken.

## Spare parts

The spare parts available are shown in heavy outline. Parts drawn in a grey line are not supplied as spares.

### Available spares

Valve assembly	4, 7, 8, 9, 10, 11, 12, 13
Bucket assembly	4, 6, 9, 10
Cover gasket (packet of 3)	4

### How to order spares

Always order spares by using the description given in the column headed 'Available spares' and state the type of trap, pressure rating and size and type of the connections.

**Example:** 1 - Valve assembly for a Spirax Sarco IBV-Z-123-110-3"- Flanged ASME Class 300 inverted bucket vertical steam trap.

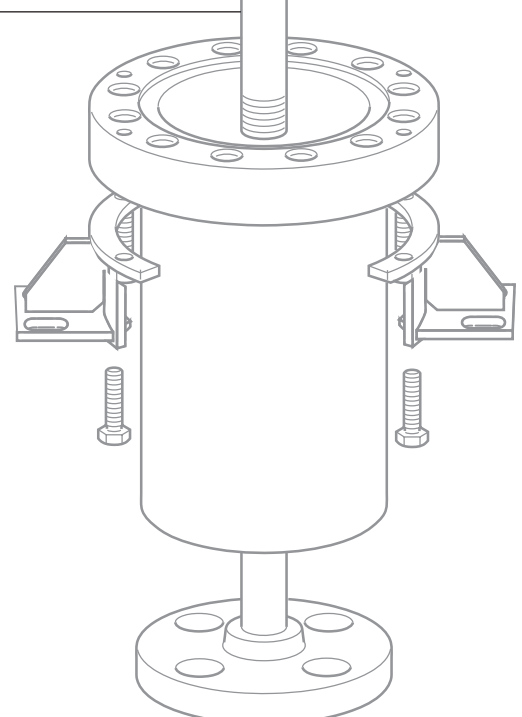
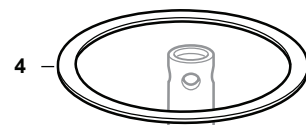
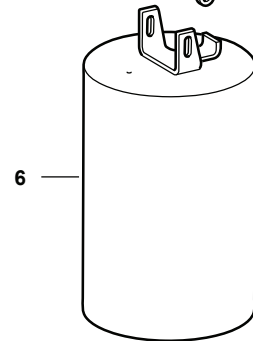
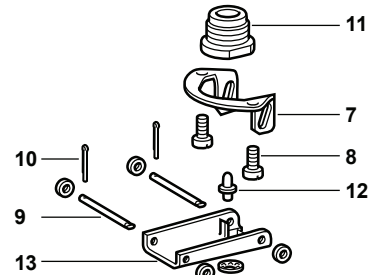
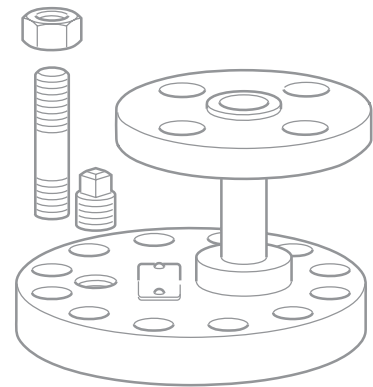

### Optional extra

Inbuilt stainless steel check valve

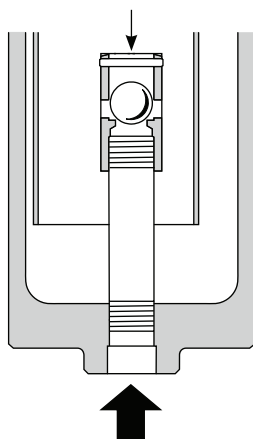

Please note that this option is only available for units that have a DP maximum differential pressure of 40 bar and above - See the IBV product nomenclature and selection guide on page 13 for clarification.