



## IBV Series C Carbon Steel Inverted Bucket Vertical Steam Trap

### Description

The IBV series C inverted bucket steam trap is manufactured using carbon steel for the body and cover; with internal components being made of stainless steel. It is suitable for use with saturated and superheated steam and in high pressure and high temperature applications. The IBV is fully automatic and has been designed in such a way that there is minimal friction from mechanism movement; valve closure is immediate, without any steam loss and the discharge action is positive with no equivocal phases. The standard version will be supplied with bolted support brackets.

**On the cover of the IBV** there is a  $\frac{3}{8}$ " hole, threaded and plugged, to eliminate any water discharge after being hydraulically tested before leaving the factory. This hole can be reopened on site for the customer to perform periodic hydro testing.

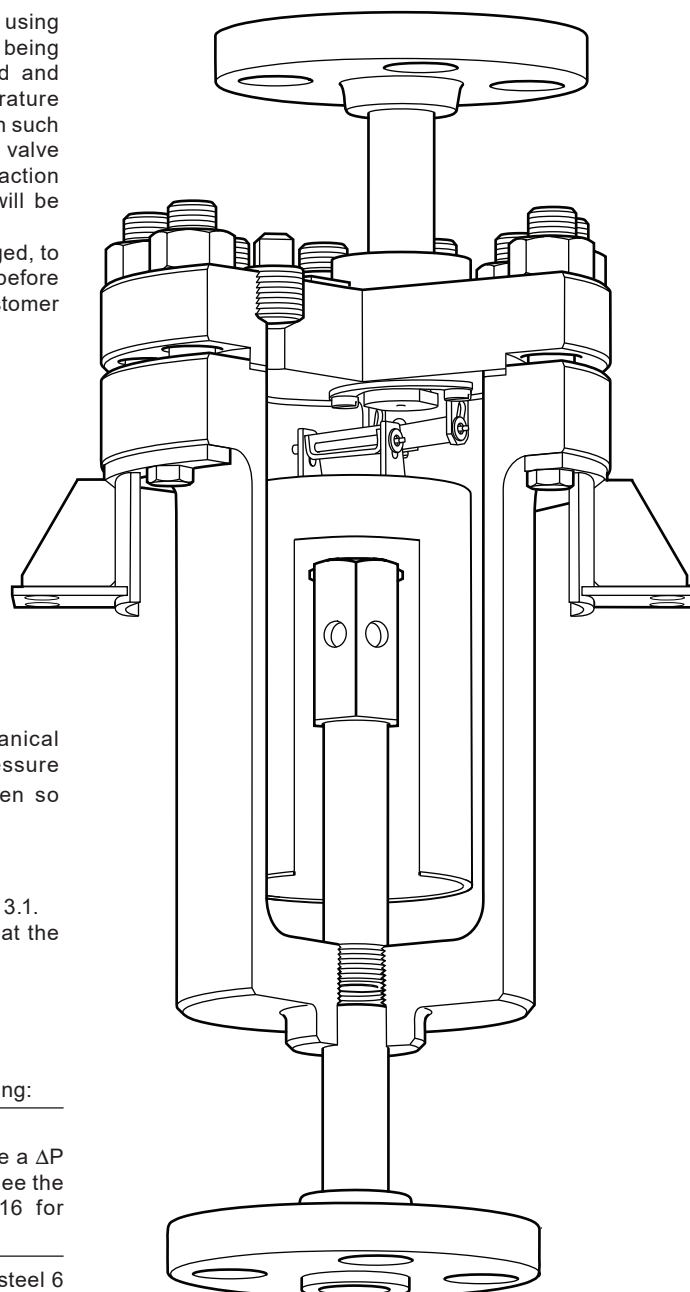

### Standards

This steam trap is designed following the ASME VIII Mechanical Design Code and complies with the requirements of the Pressure Equipment Directive (PED) and carries the **CE** mark when so required.

### Certification

The product is available with material certification to EN 10204 3.1.

**Note:** All certification/inspection requirements must be stated at the time of order placement.

### Optional extras

On request the IBV steam trap can be equipped with the following:

#### An inbuilt stainless steel check valve

**Please note** that this option is only available for units that have a  $\Delta P$  maximum differential pressure of 40 bar (580 psi) and above - See the IBV product nomenclature and selection guide on page 16 for clarification.

#### A Stellite plug and seat

Alloy steel 6

## Available types

---

**Series C**      **Carbon steel** body and cover

**Series C-LF2**    **Carbon steel** body and cover with a material specification of **A350 LF2** for low temperature applications down to -46 °C (-50.8 °F)

**See** TI-P067-13

**Series Z**      **Alloy steel** body and cover

**See** TI-P067-15

## Sizes and pipe connections

**Please note** that all standard flanges (as noted below) will be slip-on type. Weld-neck type flanges can be supplied to special order and must be specified at the time of order placement.

---

**1/2", 3/4", 1", 1 1/2", 2" and 3"**

Screwed BSP or NPT

Socket weld, according to ASME B 16.11

---

**1/2", 3/4", 1", 1 1/2", 2" and 3"**

Flanged ASME B 16.5 ASME Class 150, 300, 600, 900 and 1500\*

---

**DN15, DN20, DN25, DN40, DN50 and DN80**

Flanged EN 1092 PN16, PN25, PN40, PN63, PN100 and PN160\*

---

\* **Note:** that the flanged **ASME Class 1500** units are **limited to a body rating of ASME Class 900**.

## Materials

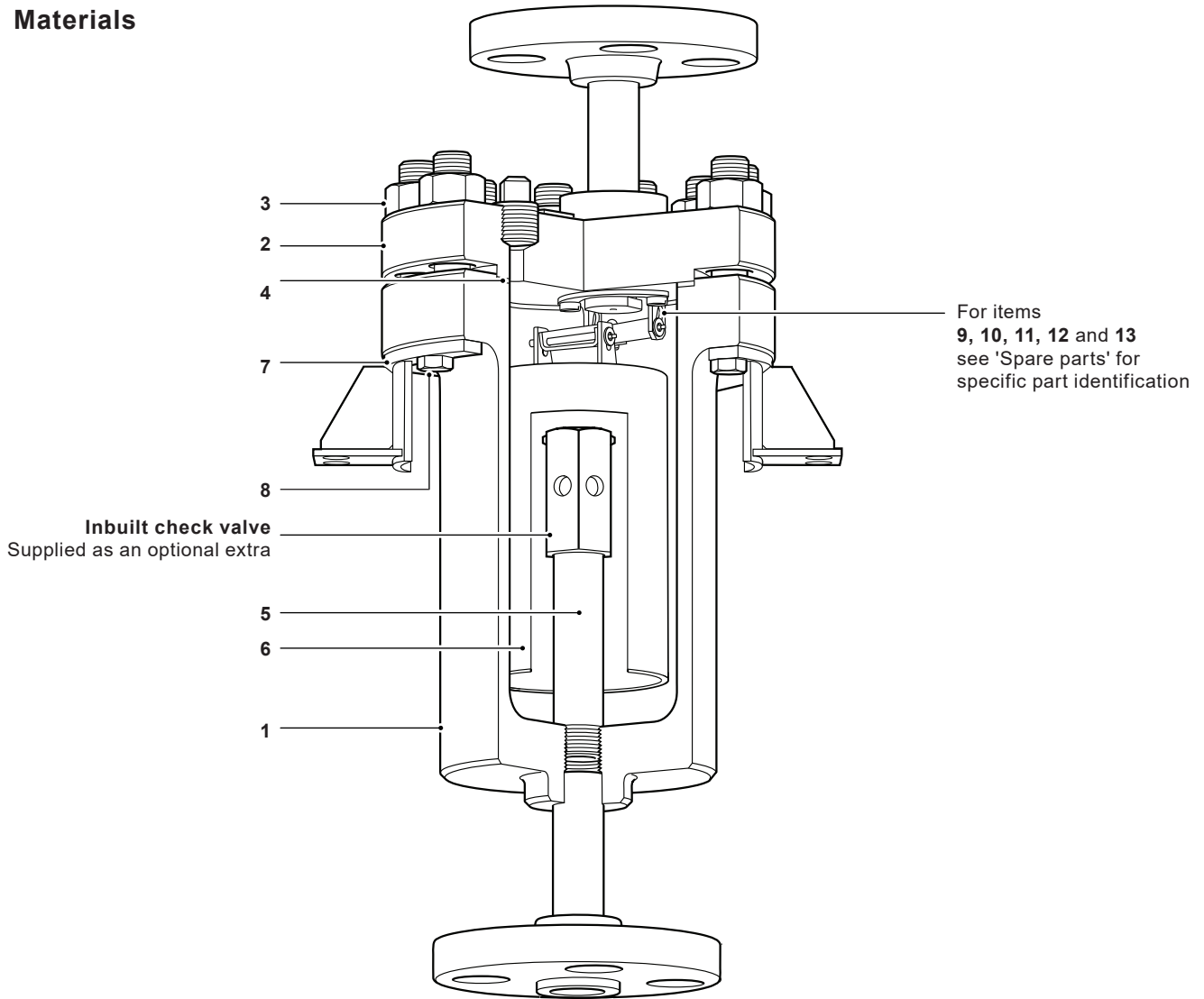

No.	Part	Material	
1	Body	Carbon steel	SA105
2	Cover	Carbon steel	SA105
	Stud bolts	Carbon steel	SA193 Gr.B7
	Nuts	Carbon steel	SA194 Gr 2H
3		(external only)	ASTM A479 XM-19
	Nace version	Stud Bolts	SA479XM-19
		Nuts	SA194 Gr.8M
4	Cover gasket	Reinforced graphite	
5	Channelling pipe	Stainless steel	SA106 Gr. B
6	Bucket	Stainless steel	AISI 316
7	Support bracket	Stainless steel	SA516 Gr.60
8	Bracket screw	Stainless steel	AISI 316
9	Lever pin	Stainless steel	AISI 316
10	Split pin	Stainless steel	AISI 316
11	Valve seat	Stainless steel	400 series
12	Valve head	Stainless steel	400 series
13	Valve lever	Stainless steel	AISI 316

## Pressure/temperature limits (ISO 6552) - Screwed, Socket weld and Flanged ASME

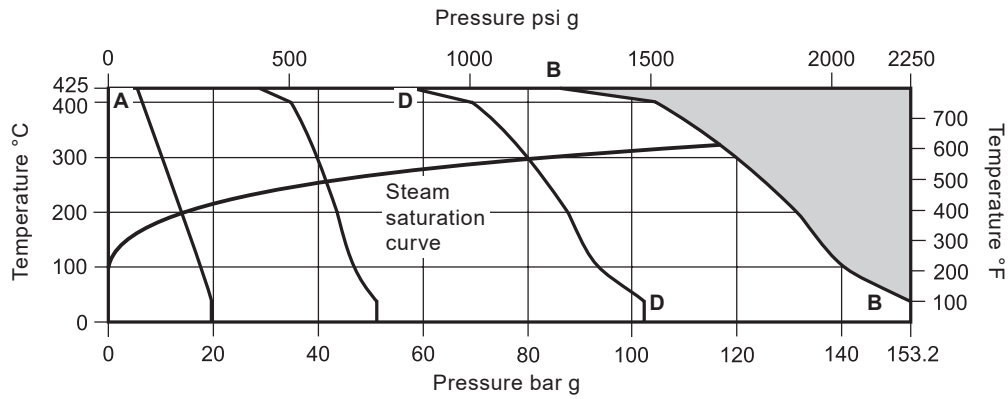

The product **must not** be used in this region or beyond the parameter of the PMA or TMA of the relative end connection.

\* **Please note** that the PMO (PS) is limited to the maximum  $\Delta P$  of the selected IBV.

		Body design conditions	ASME Class 900
A-B-B	Screwed and Socket weld ASME Class 900	PMA - Maximum allowable pressure	153.2 bar g @ 38 °C      2 220 psi g @ 100 °F
		TMA - Maximum allowable temperature	425 °C @ 86.3 bar g      797 °F @ 1252 psi g
		Minimum allowable temperature	-29 °C      -20 °F
		* PMO (PS) - Maximum operating pressure for saturated steam service	116.3 bar g @ 323 °C      1 687 psi g @ 613 °F
		TMO (TS) - Maximum operating temperature for saturated steam service	323 °C @ 116.3 bar g      613 °F @ 1 687 psi g
		Designed for a maximum cold hydraulic test pressure of:	229.8 bar g      3 333 psi g
A-D-D	ASME Class 600	PMA - Maximum allowable pressure	102.1 bar g @ 38 °C      1 481 @ 100 °F
		TMA - Maximum allowable temperature	425 °C @ 57.5 bar g      800 °F @ 825 psi g
		Minimum allowable temperature	-29 °C      -20 °F
		* PMO (PS) - Maximum operating pressure for saturated steam service	79.9 bar g @ 295 °C      1 159 psi g @ 563 °F
		TMO (TS) - Maximum operating temperature for saturated steam service	295 °C @ 79.9 bar g      563 °F @ 1 159 psi g
		Designed for a maximum cold hydraulic test pressure of:	153.1 bar g      2 221 psi g

## Pressure/temperature limits (ISO 6552) - Screwed, Socket weld and Flanged ASME (cont'd)

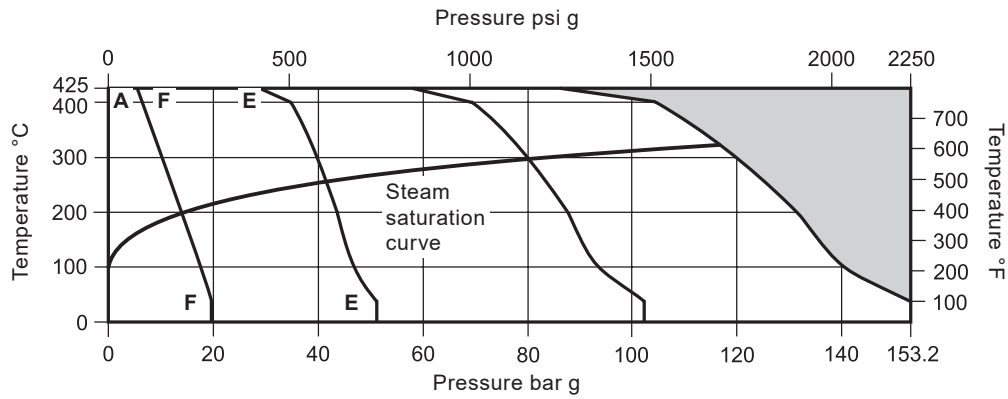

The product **must not** be used in this region or beyond the parameter of the PMA or TMA of the relative end connection.

\* **Please note** that the PMO (PS) is limited to the maximum  $\Delta P$  of the selected IBV.

<b>A-E-E</b>	<b>ASME Class 300</b>		PMA - Maximum allowable pressure	51.1 bar g @ 38 °C	741 psi g @ 100 °F
			TMA - Maximum allowable temperature	425 °C @ 28.8 bar g	797 °F @ 410 psi g
			Minimum allowable temperature	-29 °C	-20 °F
		*	PMO (PS) - Maximum operating pressure for saturated steam service	41.7 bar g @ 254 °C	605 psi g @ 489 °F
			TMO (TS) - Maximum operating temperature for saturated steam service	254 °C @ 41.7 bar g	489 °F @ 605 psi g
			Designed for a maximum cold hydraulic test pressure of:	76.6 bar g	1111 psi g
<b>A-F-F</b>	<b>ASME Class 150</b>		PMA - Maximum allowable pressure	19.6 bar g @ 38 °C	284 psi g @ 100 °F
			TMA - Maximum allowable temperature	425 °C @ 5.5 bar g	797 °F @ 80 psi g
			Minimum allowable temperature	-29 °C	-20 °F
		*	PMO (PS) - Maximum operating pressure for saturated steam service	13.8 bar g @ 197 °C	200 psi g @ 387 °F
			TMO (TS) - Maximum operating temperature for saturated steam service	197 °C @ 13.8 bar g	387 °F @ 200 psi g
			Designed for a maximum cold hydraulic test pressure of:	29.4 bar g	426 psi g

## Pressure/temperature limits (ISO 6552) - Flanged EN1092-1

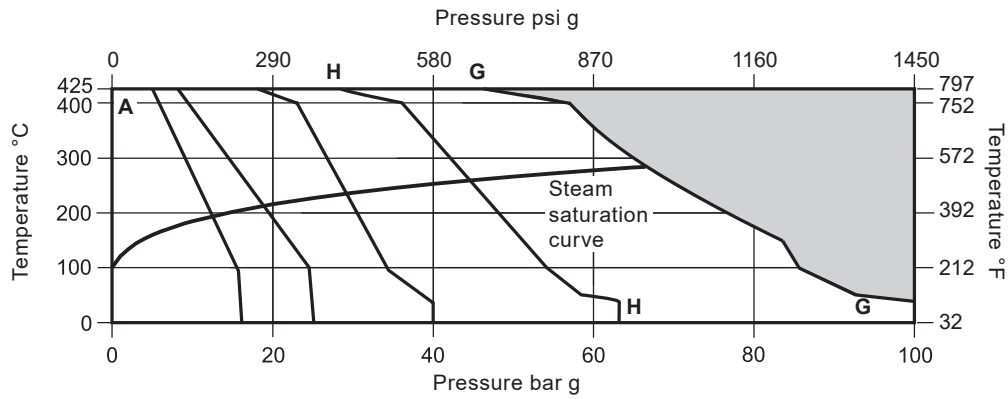

The product **must not** be used in this region or beyond the parameter of the PMA or TMA of the relative end connection.

\* Please note that the PMO (PS) is limited to the maximum  $\Delta P$  of the selected IBV.

Body design conditions		PN100	
PMA - Maximum allowable pressure		100 bar g @ 50 °C	1450 psi g @ 122 °F
TMA - Maximum allowable temperature		425 °C @ 44.9 bar g	797 °F @ 651 psi g
Minimum allowable temperature		-29 °C	-20.2 °F
<b>A-G-G</b>	<b>PN100</b>		
* PMO (PS)	- Maximum operating pressure for saturated steam service	66 bar g	957 psi g
TMO (TS)	Maximum operating temperature for saturated steam service	283 °C @ 44.9 bar g	541 °F @ 651 psi g
Designed for a maximum cold hydraulic test pressure of:		143 bar g	2074 psi g
PMA - Maximum allowable pressure		63 bar g @ 50 °C	914 psi g @ 122 °F
TMA - Maximum allowable temperature		425 °C @ 28.3 bar g	797 °F @ 410 psi g
Minimum allowable temperature		-29 °C	-20.2 °F
<b>A-H-H</b>	<b>PN63</b>		
* PMO (PS)	- Maximum operating pressure for saturated steam service	44 bar g	638 psi g
TMO (TS)	Maximum operating temperature for saturated steam service	257 °C @ 28.3 bar g	495 °F @ 410 psi g
Designed for a maximum cold hydraulic test pressure of:		90 bar g	1305 psi g

## Pressure/temperature limits (ISO 6552) - Flanged EN1092-1 (continued)

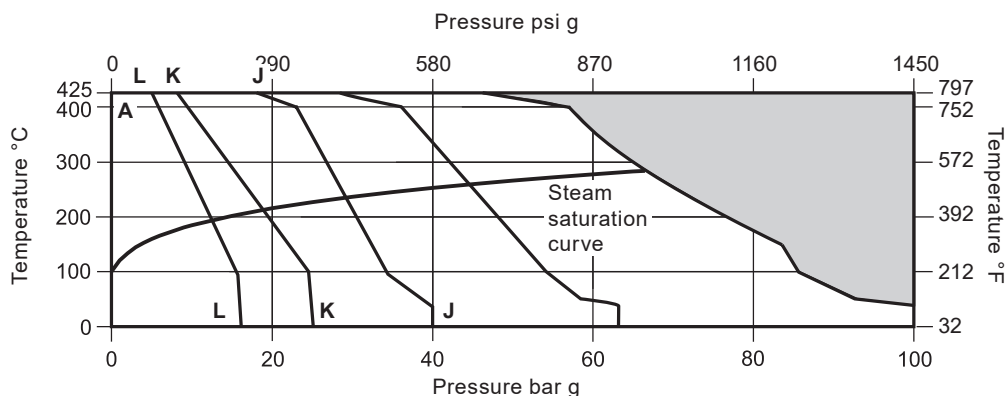

The product **must not** be used in this region or beyond the parameter of the PMA or TMA of the relative end connection.

\* **Please note** that the PMO (PS) is limited to the maximum  $\Delta P$  of the selected IBV.

		PMA - Maximum allowable pressure	40 bar g @ 50 °C	580 psi g @ 122 °F
		TMA - Maximum allowable temperature	425 °C @ 17.9 bar g	797 °F @ 260 psi g
		Minimum allowable temperature	-29 °C	-20.2 °F
<b>A-J-J</b>	<b>PN40</b>	* PMO (PS) - Maximum operating pressure for saturated steam service	29 bar g	421 psi g
		TMO (TS) - Maximum operating temperature for saturated steam service	234 °C @ 17.5 bar g	453 °F @ 254 psi g
		Designed for a maximum cold hydraulic test pressure of:	57.2 bar g	830 psi g
		PMA - Maximum allowable pressure	25 bar g @ 50 °C	363 psi g @ 122 °F
		TMA - Maximum allowable temperature	425 °C @ 11.2 bar g	797 °F @ 162 psi g
		Minimum allowable temperature	-29 °C	-20.2 °F
<b>A-K-K</b>	<b>PN25</b>	* PMO (PS) - Maximum operating pressure for saturated steam service	19 bar g	276 psi g
		TMO (TS) - Maximum operating temperature for saturated steam service	212 °C @ 11.2 bar g	414 °F @ 162 psi g
		Designed for a maximum cold hydraulic test pressure of:	35.7 bar g	518 psi g
		PMA - Maximum allowable pressure	16 bar g @ 50 °C	232 psi g @ 122 °F
		TMA - Maximum allowable temperature	425 °C @ 7.1 bar g	797 °F @ 103 psi g
		Minimum allowable temperature	-29 °C	-20.2 °F
<b>A-L-L</b>	<b>PN16</b>	* PMO (PS) - Maximum operating pressure for saturated steam service	12 bar g	174 psi g
		TMO (TS) - Maximum operating temperature for saturated steam service	191 °C @ 7.1 bar g	376 °F @ 103 psi g
		Designed for a maximum cold hydraulic test pressure of:	22.8 bar g	331 psi g

## Capacities - DN15

**Note:** IBV inverted bucket steam traps should be selected for use at the most appropriate working differential pressure and not on the basis of load.

**Condensate discharge capacities (kg/h)** - The discharge capacities in the table are referring to the operating temperature of the saturated steam and the PMO (PS) of the steam trap shall be the relevant  $\Delta P$  maximum differential pressure of each specific model.

**For optimum trap selection you need to know the following criteria:**

- a) The hourly amount of condensate to be discharged, inclusive of the safety factor: x 1.5 for continuous use, x 2 to x 3 for intermittent use.
- b) The effective differential pressure.

### Working example:

Condensate discharge = 500 kg/h

Effective differential pressure = 30 bar

Upstream pressure = 45 bar g

Backpressure = 15 bar g

**The unit of choice** would have a  $\Delta P$  max. differential pressure of **70 bar** which is greater than the upstream pressure.

For full product selection and nomenclature follow the guide on page 13.

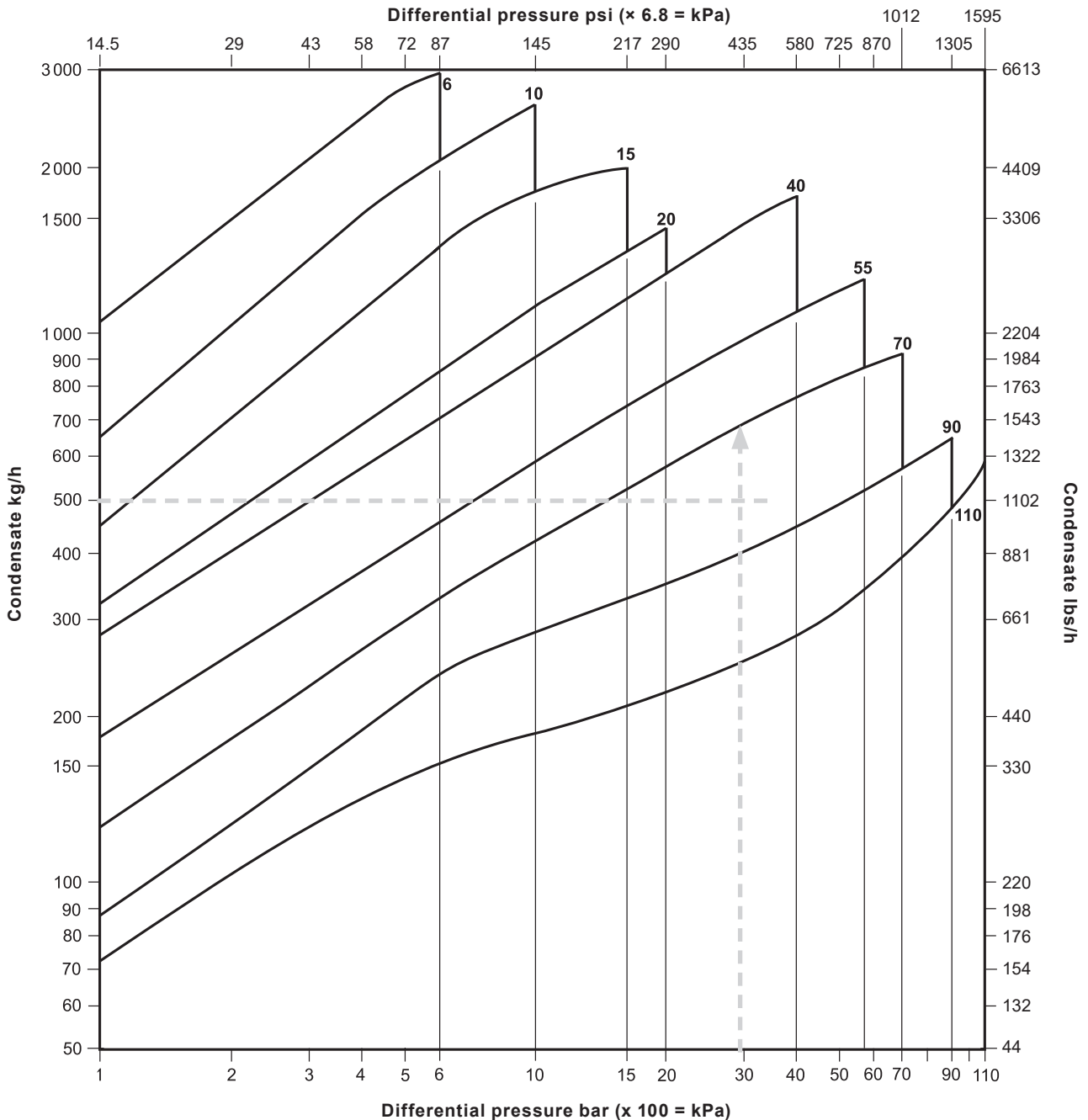



## Capacities - DN20

**Note:** IBV inverted bucket steam traps should be selected for use at the most appropriate working differential pressure and not on the basis of load.

**Condensate discharge capacities (kg/h)** - The discharge capacities in the table are referring to the operating temperature of the saturated steam and the PMO (PS) of the steam trap shall be the relevant  $\Delta P$  maximum differential pressure of each specific model.

**For optimum trap selection you need to know the following criteria:**

- The hourly amount of condensate to be discharged, inclusive of the safety factor: x 1.5 for continuous use, x 2 to x 3 for intermittent use.
- The effective differential pressure.

### Working example:

Condensate discharge = 1050 kg/h

Effective differential pressure = 30 bar

Upstream pressure = 45 bar g

Backpressure = 15 bar g

**The unit of choice** would have a  $\Delta P$  max. differential pressure of **55 bar** which is greater than the upstream pressure.

For full product selection and nomenclature follow the guide on page 13.

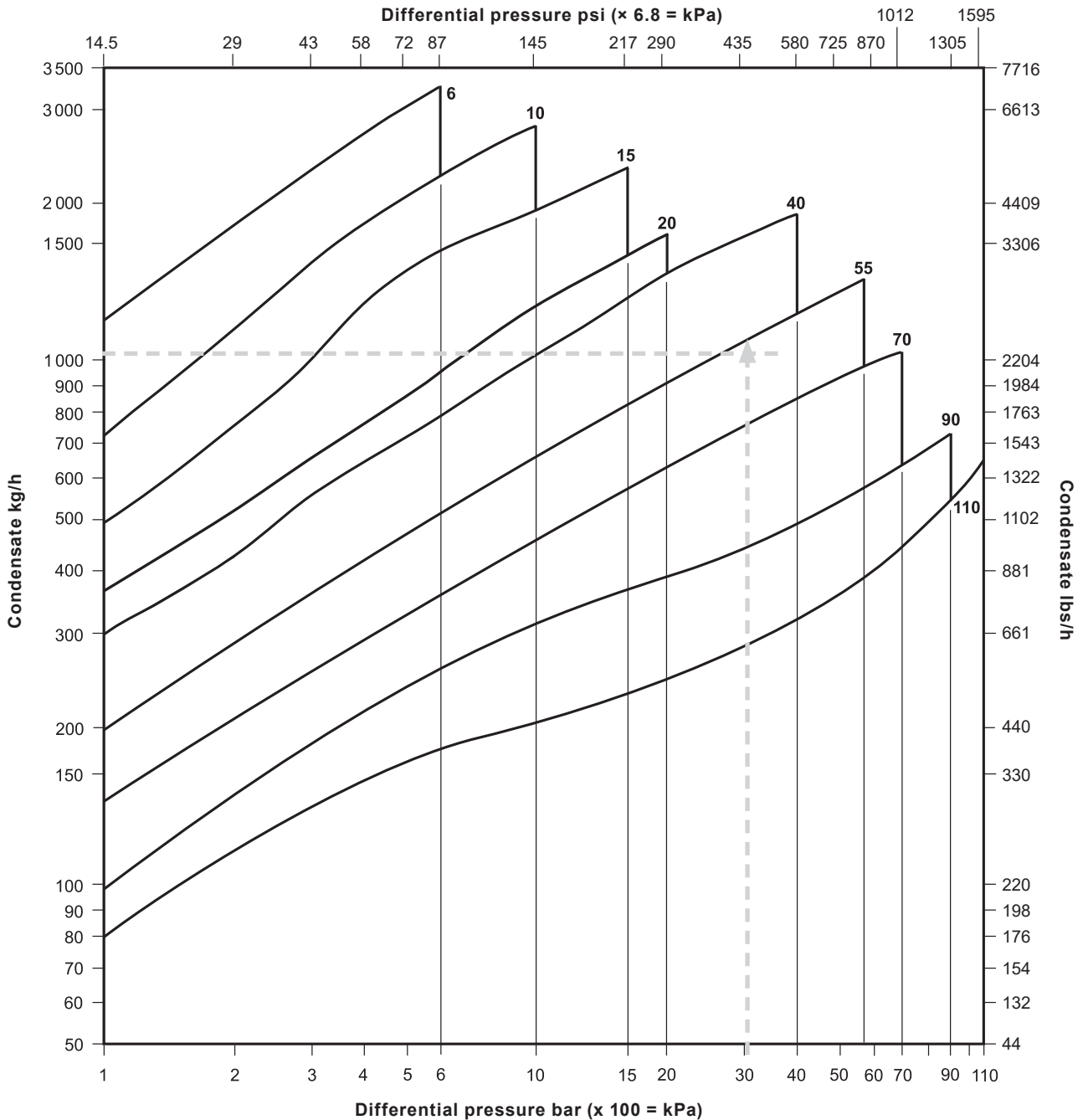

## Capacities - DN25

**Note:** IBV inverted bucket steam traps should be selected for use at the most appropriate working differential pressure and not on the basis of load.

**Condensate discharge capacities (kg/h)** - The discharge capacities in the table are referring to the operating temperature of the saturated steam and the PMO (PS) of the steam trap shall be the relevant  $\Delta P$  maximum differential pressure of each specific model.

**For optimum trap selection you need to know the following criteria:**

- a) The hourly amount of condensate to be discharged, inclusive of the safety factor: x 1.5 for continuous use, x 2 to x 3 for intermittent use.
- b) The effective differential pressure.

### Working example:

Condensate discharge = 2000 kg/h

Effective differential pressure = 4 bar

Upstream pressure = 5 bar g

Backpressure = 1 bar g

**The unit of choice** would have a  $\Delta P$  max. differential pressure of **15 bar** which is greater than the upstream pressure.

For full product selection and nomenclature follow the guide on page 13.

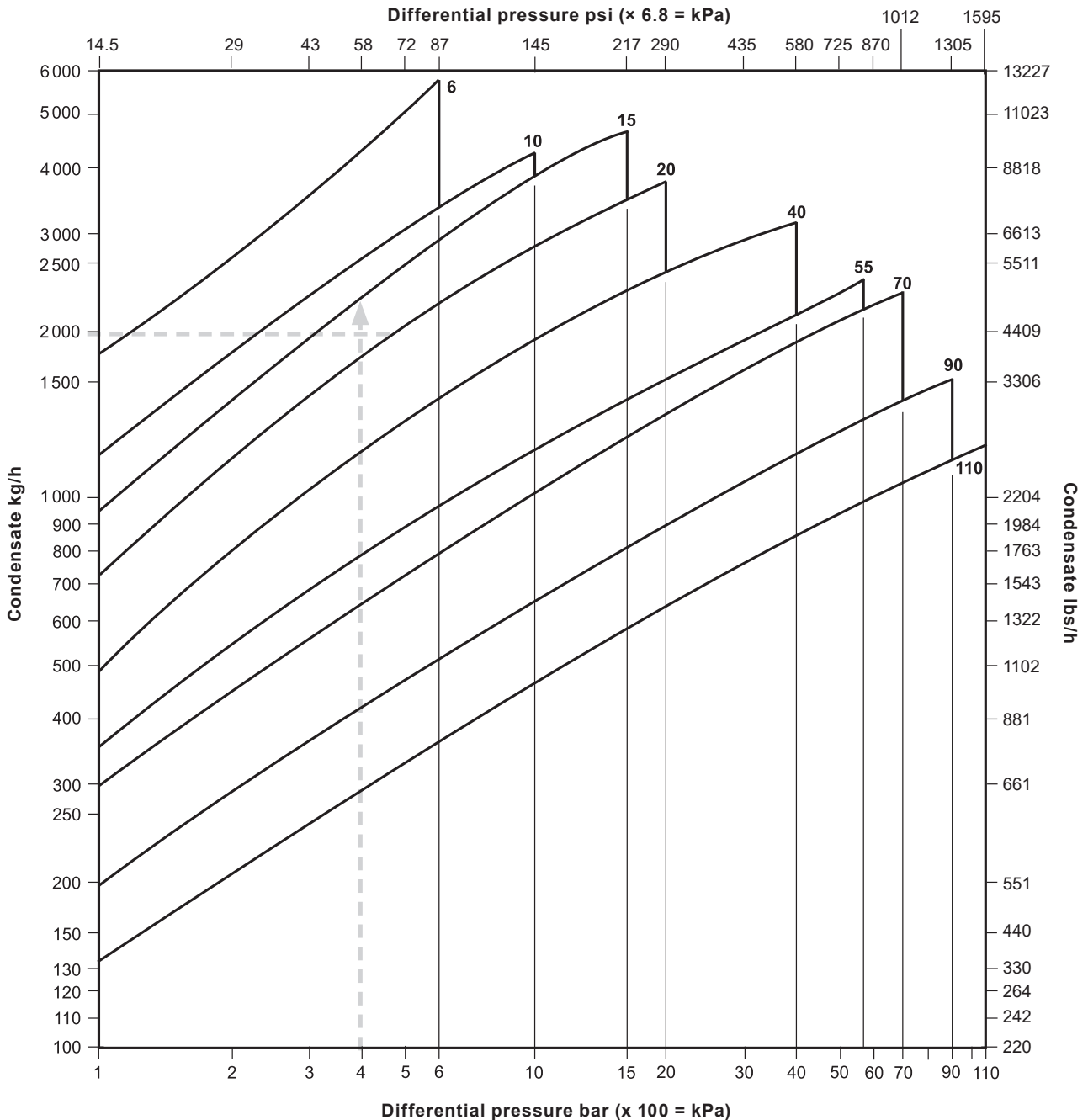

## Capacities - DN40

**Note:** IBV inverted bucket steam traps should be selected for use at the most appropriate working differential pressure and not on the basis of load.

**Condensate discharge capacities (kg/h)** - The discharge capacities in the table are referring to the operating temperature of the saturated steam and the PMO (PS) of the steam trap shall be the relevant  $\Delta P$  maximum differential pressure of each specific model.

**For optimum trap selection you need to know the following criteria:**

- The hourly amount of condensate to be discharged, inclusive of the safety factor: x 1.5 for continuous use, x 2 to x 3 for intermittent use.
- The effective differential pressure.

### Working example:

Condensate discharge = 2000 kg/h

Effective differential pressure = 50 bar

Upstream pressure = 75 bar g

Backpressure = 25 bar g

**The unit of choice** would have a  $\Delta P$  max. differential pressure of **110 bar** which is greater than the upstream pressure.

For full product selection and nomenclature follow the guide on page 13.

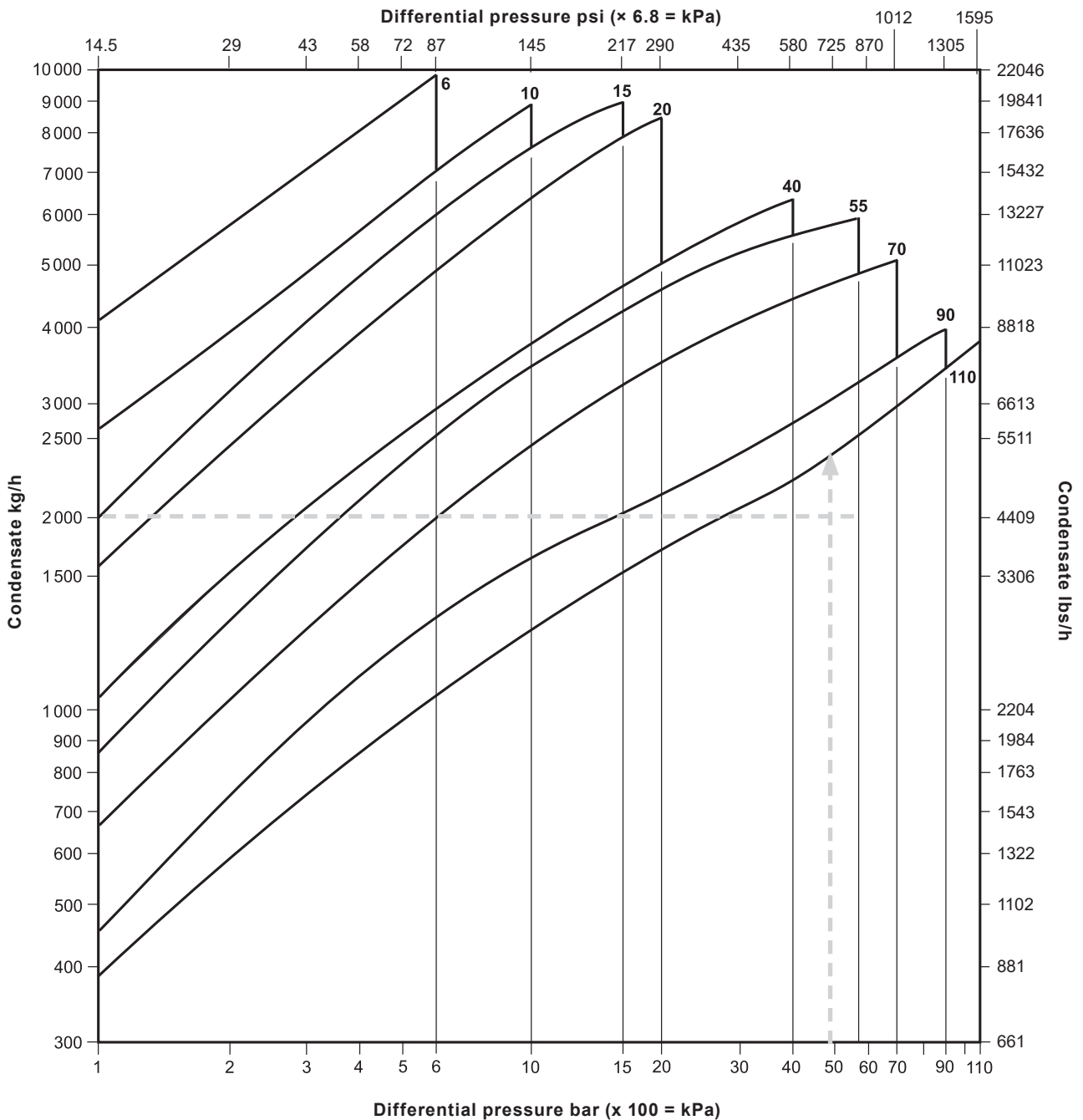

## Capacities - DN50

**Note:** IBV inverted bucket steam traps should be selected for use at the most appropriate working differential pressure and not on the basis of load.

**Condensate discharge capacities (kg/h)** - The discharge capacities in the table are referring to the operating temperature of the saturated steam and the PMO (PS) of the steam trap shall be the relevant  $\Delta P$  maximum differential pressure of each specific model.

**For optimum trap selection you need to know the following criteria:**

- a) The hourly amount of condensate to be discharged, inclusive of the safety factor: x 1.5 for continuous use, x 2 to x 3 for intermittent use.
- b) The effective differential pressure.

### Working example:

Condensate discharge = 6000 kg/h

Effective differential pressure = 8 bar

Upstream pressure = 10 bar g

Backpressure = 2 bar g

**The unit of choice** would have a  $\Delta P$  max. differential pressure of **20 bar** which is greater than the upstream pressure.

For full product selection and nomenclature follow the guide on page 13.

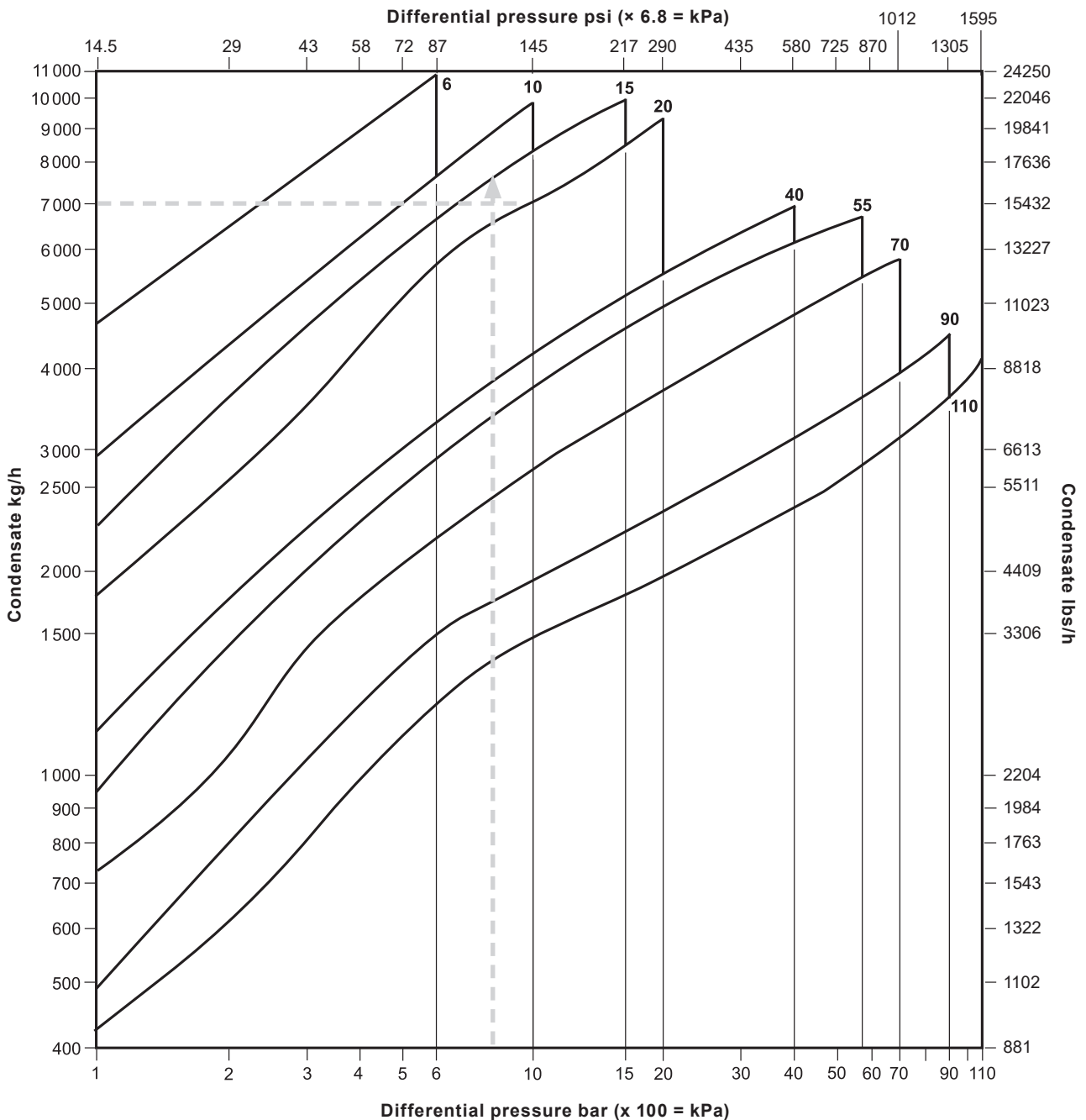

## Capacities - DN80

**Note:** IBV inverted bucket steam traps should be selected for use at the most appropriate working differential pressure and not on the basis of load.

**Condensate discharge capacities (kg/h)** - The discharge capacities in the table are referring to the operating temperature of the saturated steam and the PMO (PS) of the steam trap shall be the relevant  $\Delta P$  maximum differential pressure of each specific model.

**For optimum trap selection you need to know the following criteria:**

- a) The hourly amount of condensate to be discharged, inclusive of the safety factor: x 1.5 for continuous use, x 2 to x 3 for intermittent use.
- b) The effective differential pressure.

### Working example:

Condensate discharge = 5000 kg/h

Effective differential pressure = 30 bar

Upstream pressure = 55 bar g

Backpressure = 25 bar g

**The unit of choice** would have a  $\Delta P$  max. differential pressure of **90 bar** which is greater than the upstream pressure.

For full product selection and nomenclature follow the guide on page 13.

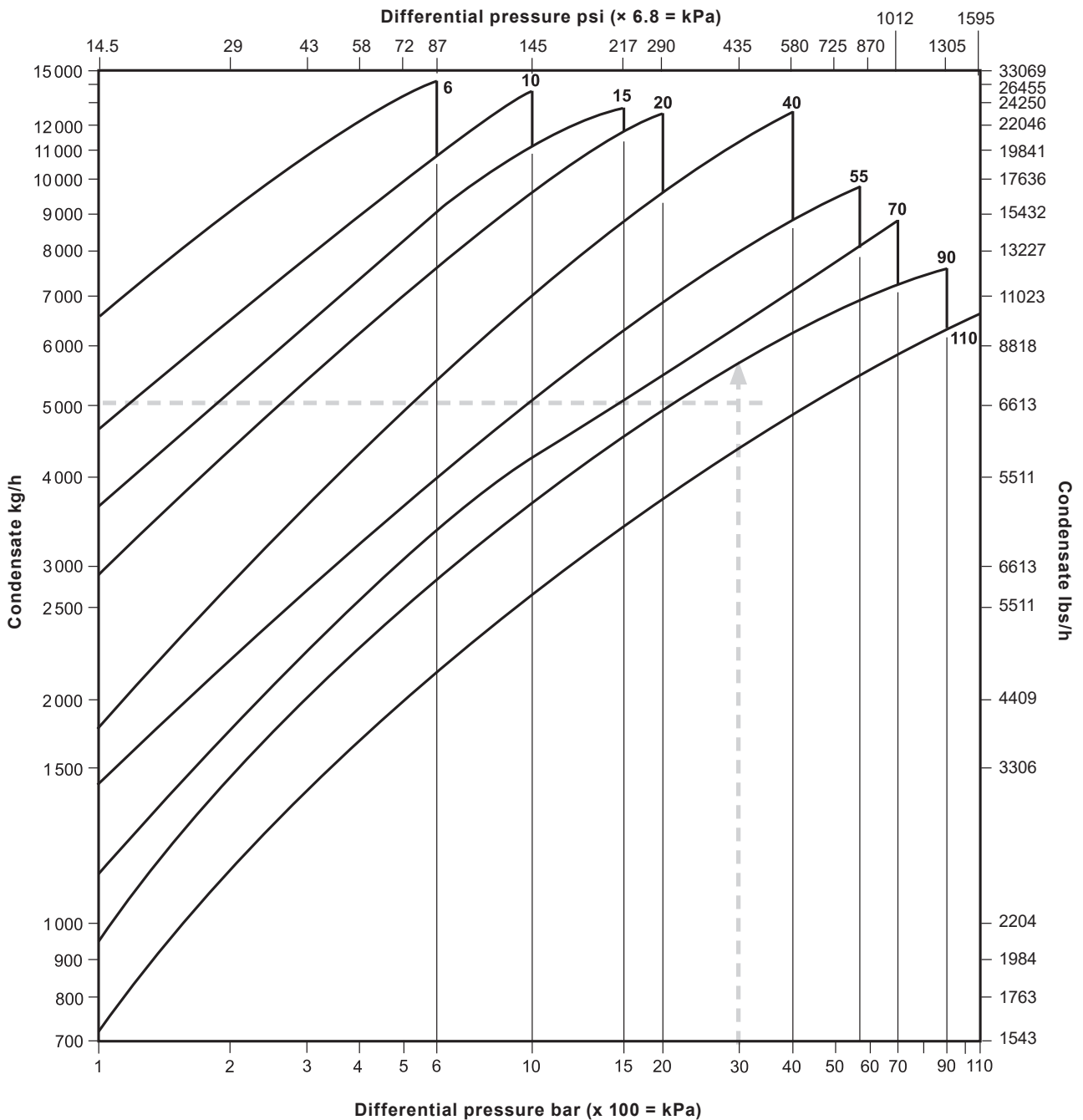

**Dimensions** (approximate) in mm (inches)

IBV size	A	B	C	D	E
DN15 1/2"	260 (10.2)	488 (19.2)	420 (16.5)	25 (0.98)	165 (6.50)
DN20 3/4"					
DN25 1"	345 (13.6)	616 (24.3)	530 (20.9)	40 (1.57)	210 (8.27)
DN40 1 1/2"	411 (16.2)	774 (30.5)	650 (25.6)	39 (1.54)	265 (10.4)
DN50 2"		782 (30.8)			
DN80 3"	532 (20.9)	1 026 (40.4)	850 (33.5)	36 (1.42)	305 (12.0)

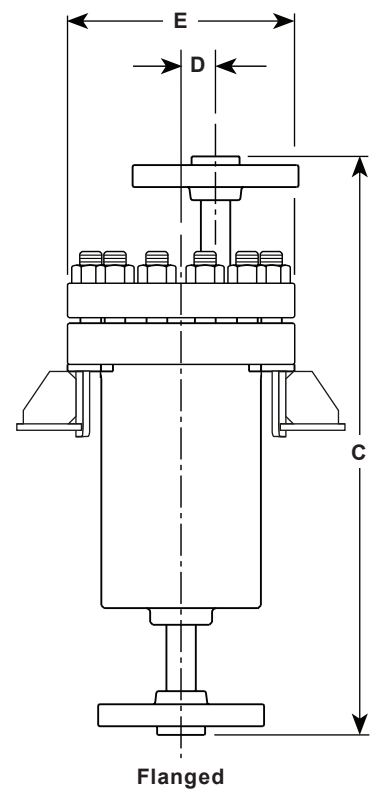
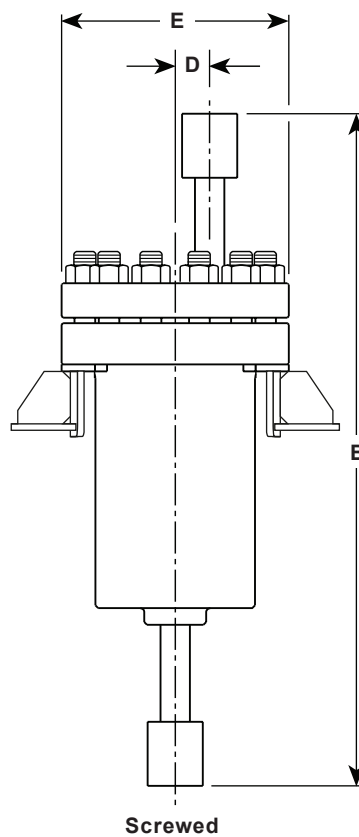
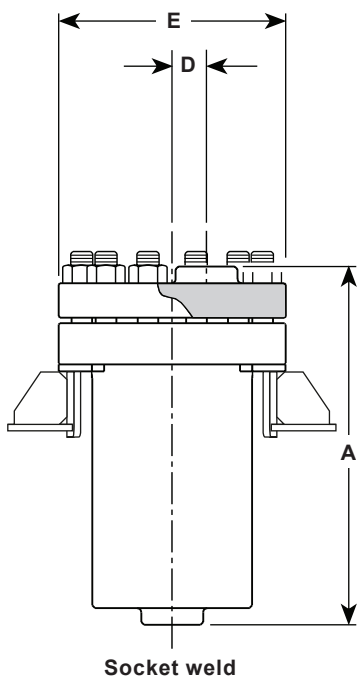

## Weights (approximate) in kg (lbs)

\* on request

IBV size	BSP + NPT	Socket weld	Flanged ASME Class:					Flanged EN 1092:				
			150	300	600	900	1500*	PN16	PN25	PN40	PN63	PN100
<b>DN15</b> ½"	20 (44.1)	18 (39.7)	20 (44.1)	20 (44.1)	20 (44.1)	22 (48.5)	22 (48.5)	20 (44.1)	20 (44.1)	20 (44.1)	20 (44.1)	22 (48.5)
<b>DN20</b> ¾"	26 (57.3)	24 (52.9)	26 (57.3)	28 (61.7)	28 (61.7)	30 (66.1)	30 (66.1)	28 (61.7)	28 (61.7)	28 (61.7)	28 (61.7)	30 (66.1)
<b>DN25</b> 1"	42 (92.6)	39 (86.0)	42 (92.6)	44 (97.0)	44 (97.0)	48 (106)	48 (106)	42 (92.6)	42 (92.6)	42 (92.6)	42 (92.6)	46 (101)
<b>DN40</b> 1½"	68 (150)	65 (143)	70 (154)	72 (159)	72 (159)	78 (172)	78 (172)	70 (154)	70 (154)	70 (154)	70 (154)	74 (163)
<b>DN50</b> 2"	68 (150)	65 (143)	72 (159)	74 (163)	76 (168)	88 (194)	88 (194)	72 (159)	72 (159)	72 (159)	74 (163)	78 (172)
<b>DN80</b> 3"	125 (276)	120 (265)	132 (291)	136 (300)	138 (304)	152 (335)	162 (357)	130 (287)	130 (287)	130 (287)	134 (295)	138 (304)

## Safety information, installation and maintenance

For full details see the Installation and Maintenance Instructions supplied with the product.

### Installation note:

The trap must be installed below the drain point with the body upright in a vertical position, the cover at the top and the inlet connection at the bottom; this orientation will ensure that the bucket mechanism will rise and fall vertically without any friction. It is recommended that a strainer is installed upstream of the IBV to protect it from contamination.

To permit safe inspection for cleaning or maintenance purpose it is again recommended that suitable shut-off valves are installed upstream and downstream of the IBV application.

It needs to be appreciated that there is blast discharge with this device, consequently the downstream accessories, if any, should be installed at a minimum distance of 1 m (3.28 ft) from the IBV.

### Disposal

This product is recyclable. No ecological hazard is anticipated with the disposal of this product providing due care is taken.

## IBV product nomenclature and selection guide:

Please note that other units are available on request to suit the specifics of a particular process application.

<b>Series</b>	C = Carbon steel	C
<b>PMO (PS) @ Saturated steam temperature for the body rating</b>	<b>Carbon steel</b> 116 bar g = ASME Class 900 body	116
<b>ΔP maximum differential pressure</b>	ΔP = 6, 10, 15, 20, 40, 55, 70, 90, 110 bar	110
<b>Size</b>	1/2", 3/4", 1", 1 1/2", 2", 3" = <b>or</b> DN15, DN20, DN25, DN40, DN50, DN80	3"
<b>Connections</b>	<b>Screwed</b> = BSP or NPT	ASME Class 300
	<b>Socket weld</b> = According to ASME B 16.11	
	<b>Flanged</b> ASME = ASME Class 150, 300, 600, 900, (*1500 available on request) EN 1092 = PN16, PN25, PN40, PN63, PN100	
<b>Optional extras</b>	Blank = Standard	
	NACE = NACE compliancy	
	CV = Check valve <b>Please note</b> that this option is only available for units that have a ΔP maximum differential pressure of 40 bar and above - See above.	

IBV product selection example:

- 
  - 
  - 
  - 
  - 
  -

### How to order

1 off Spirax Sarco IBV - C - 116 - 110 - 3" - Flanged ASME Class 300 inverted bucket vertical steam trap having a carbon steel body and cover with stainless steel internals.

The following will be supplied, if specified, at the time of order placement:

1. A special name-plate when a U-STAMP has been specified.



## Spare parts

The spare parts available are shown in heavy outline.  
Parts drawn in a grey line are not supplied as spares.

### Available spares

Valve assembly	4, 7, 8, 9, 10, 11, 12, 13
Bucket assembly	4, 6, 9, 10
Cover gasket (packet of 3)	4

### How to order spares

Always order spares by using the description given in the column headed 'Available spares' and state the type of trap, pressure rating and size and type of the connections.

**Example:** 1 - Valve assembly for a Spirax Sarco IBV - C - 116 - 110 - 3" - Flanged ASME Class 300 inverted bucket vertical steam trap.

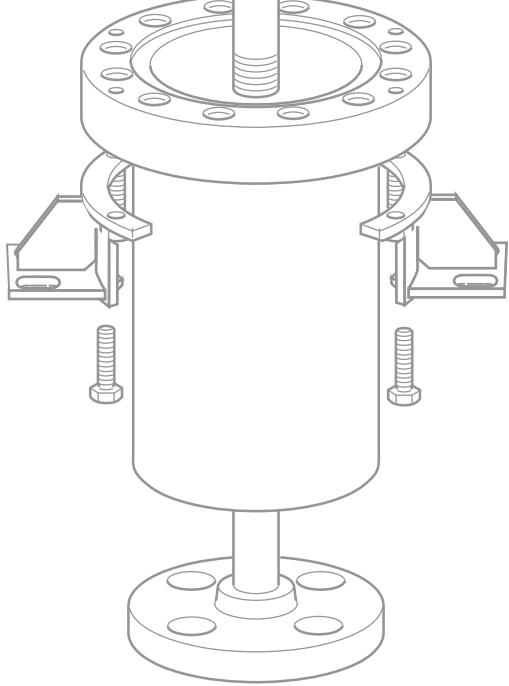
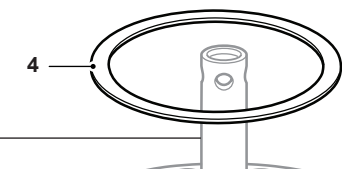
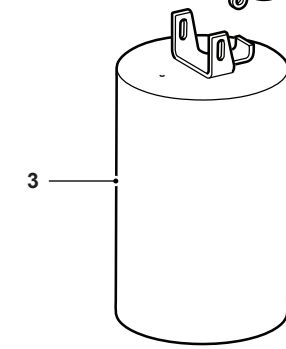
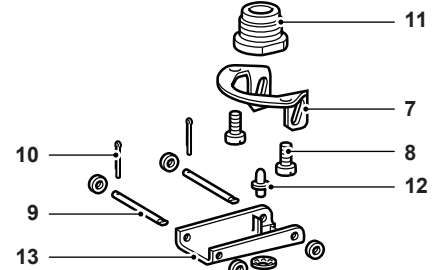
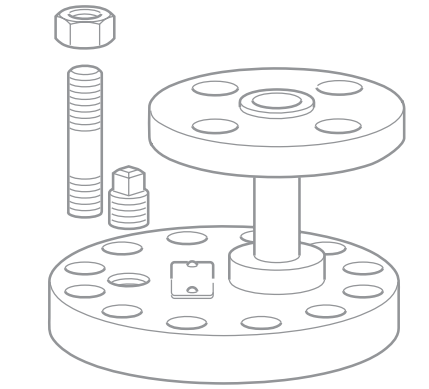

### Optional extra

Inbuilt stainless steel check valve

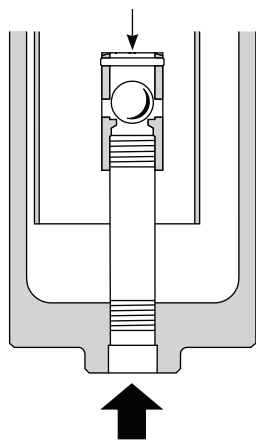

Please note that this option is only available for units that have a DP maximum differential pressure of 40 bar and above - See the IBV product nomenclature and selection guide on page 13 for clarification.