



HM34 Series Carbon Steel Inverted Bucket Steam Traps

Description

The HM34 is an inverted bucket steam trap manufactured in carbon steel with an internal strainer fitted as standard. It is designed for use on horizontal installations and will operate on steam pressures up to 32 bar g.

Standards

This product fully complies with the requirements of the Pressure Equipment Directive 2014/68/EU.

Certification

This product is available with certification to EN 10204 2.2.

Note: All certification/inspection requirements must be stated at the time of order placement.

Size 1/2" and 3/4"

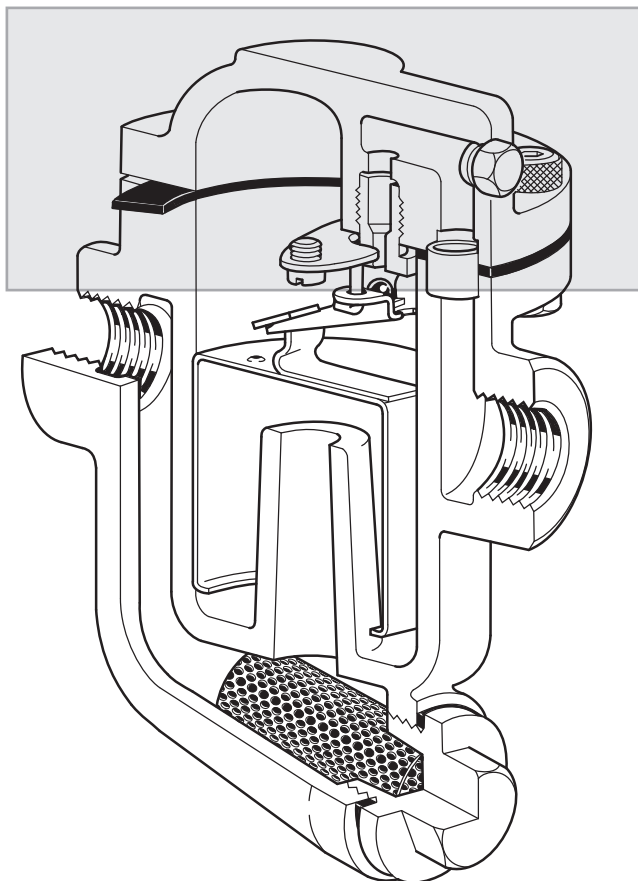

Size 1"

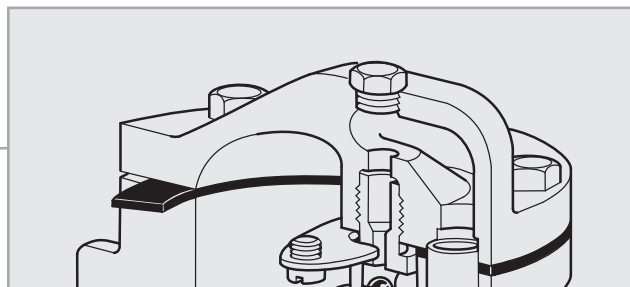

Drawing to show difference in top connection for 1" model

Sizes and pipe connections

1/2", 3/4" and 1" screwed BSP T Rp (ISO 7-1) or NPT.

DN25 socket weld ends BS 3799 Class 3000.

DN15, DN20 and DN25 standard flange EN 1092 PN40.

Available on request: Flanged Class 150 and Class 300 connections.

Pressure/temperature limits (ISO 6552)

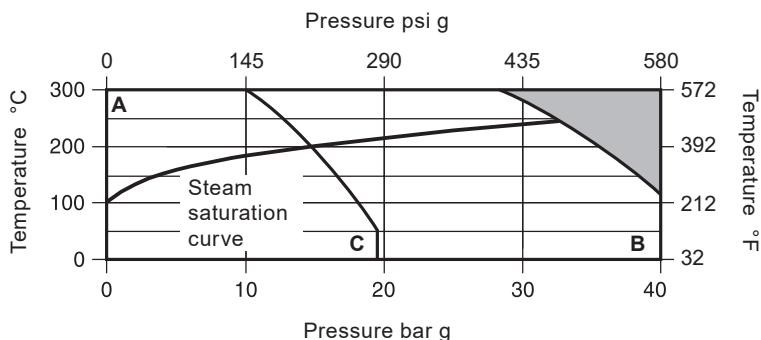

The product **must not** be used in this region.

A - B Screwed, socket weld, flanged EN 1092 PN40 and Class 300.

A - C Flanged Class 150

Body design conditions						PN40
PMA	Maximum allowable pressure	40 bar g @ 120 °C		580 psi g @ 248 °F		
TMA	Maximum allowable temperature	300 °C		572 °F		
	Minimum allowable temperature	-10 °C		14 °F		
PMO	Maximum operating pressure for saturated steam service	32 bar g		464 psi g		
TMO	Maximum operating temperature	300 °C		572 °F		
	Minimum operating temperature	0 °C		32 °F		
ΔPMX	Maximum differential pressure					
Size	4 bar (58 psi)	8.5 bar (123 psi)	12 bar (174 psi)	20 bar (290 psi)	32 bar (464 psi)	
DN15 - ½"	HM34/8	HM34/7	HM34/6	HM34/5	HM34/4	
DN20 - ¾"	HM34/10	HM34/8	HM34/7	HM34/6	HM34/5	
DN25 - 1"	HM34/12	HM34/10	HM34/8	HM34/6	HM34/5	
Designed for a maximum cold hydraulic test pressure of:		60 bar g		870 psi g		

Materials

Size 1/2" and 3/4"

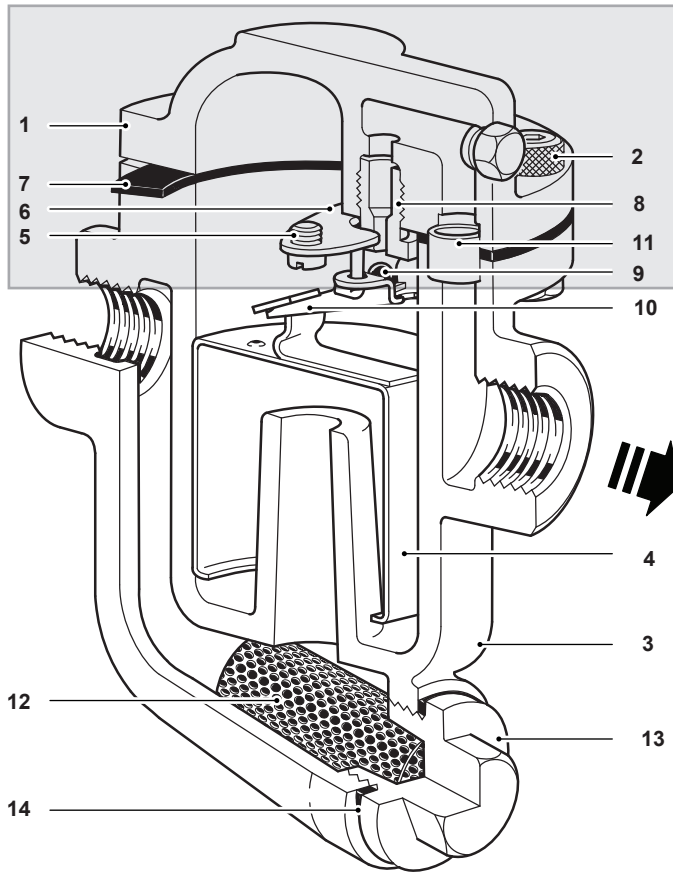

Size 1"

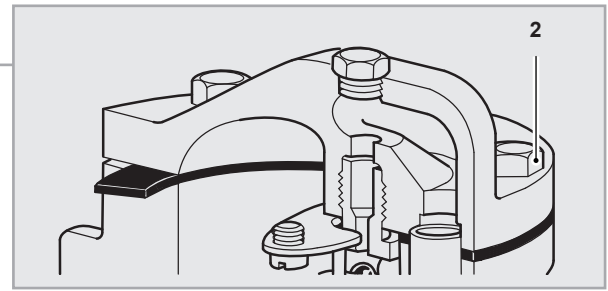

Drawing to show difference in top connection for 1" model

No.	Part	Material	
1	Cover	1/2", 3/4"	Forged steel 1.0460 (C22.8)
		1"	Cast steel 1.0619 +N
	Cover screws	1/2", 3/4"	Steel BS 4168 Gr. 8.8
2	Cover bolts	1"	Steel BS 3692 Gr. 8.8
		Cover nuts	1/2", 3/4", 1" Steel BS 3692 Gr. 8.8
3	Body	Cast steel	1.0619 +N
4	Bucket	Stainless steel	BS 1449 304 S31
5	Valve guide plate screw	Stainless steel M 4.5 x 10	BS 4183 18/8
6	Valve guide plate	Stainless steel	BS 1449 304 S11
7	Cover gasket	Reinforced exfoliated graphite	
8	Valve seat	Stainless steel	AISI 431
9	Valve	Stainless steel	AISI 440B
10	Valve lever	Stainless steel	BS 1449 321 S31
11	Ferrule	1/2", 3/4"	Stainless steel BS 970 321 S31
		1"	Stainless steel BS 3605 (CFS) 304 S14
12	Strainer screen	Stainless steel	ASTM A240 316L
13	Strainer cap	Steel	1.0460 (C22.8)
14	Strainer gasket	Reinforced exfoliated graphite	

Capacities

1/2"
DN15

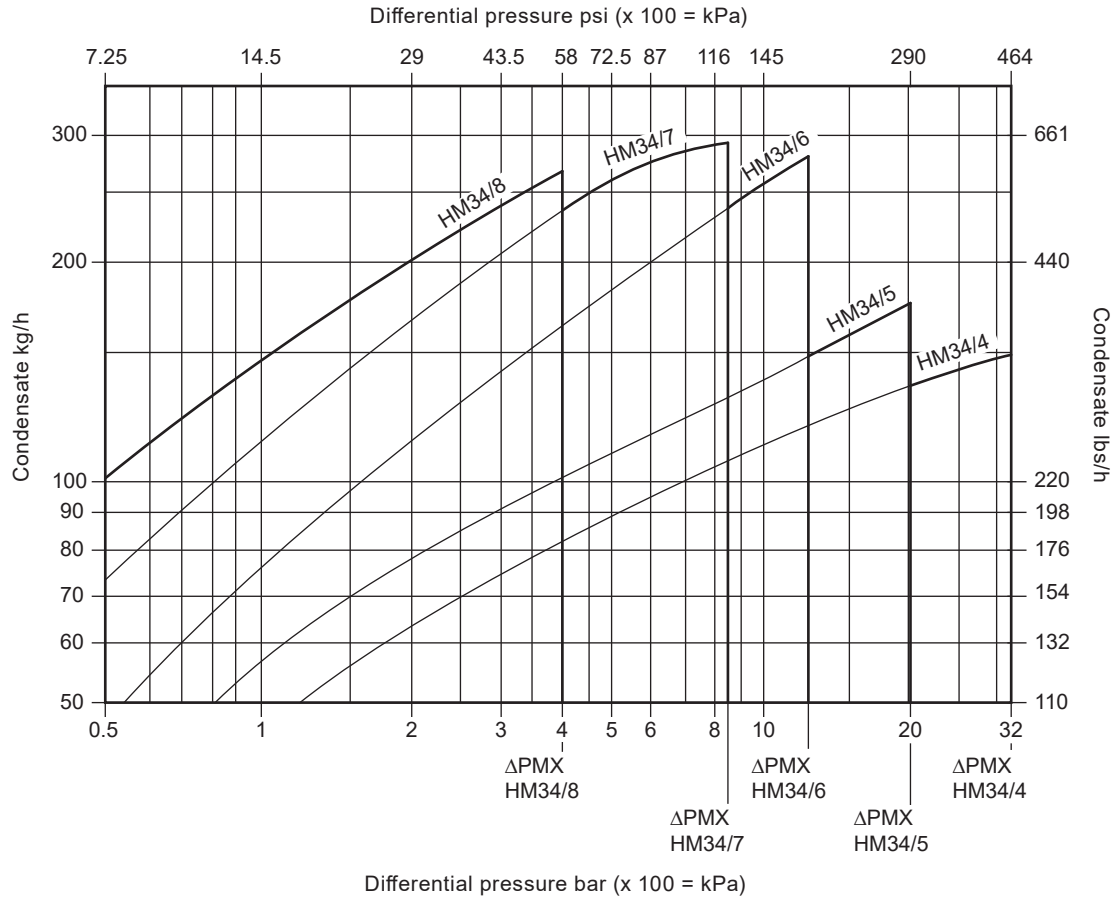

Selection note

Traps should be selected for the most appropriate working pressure differential and not on the basis of load, For example; DN25 HM34 with a load of 80 kg/h (176.3 lbs) at 7 bar (101.5 psi) differential should be handled by an HM34/10 and not an HM34/5.

3/4"
DN20

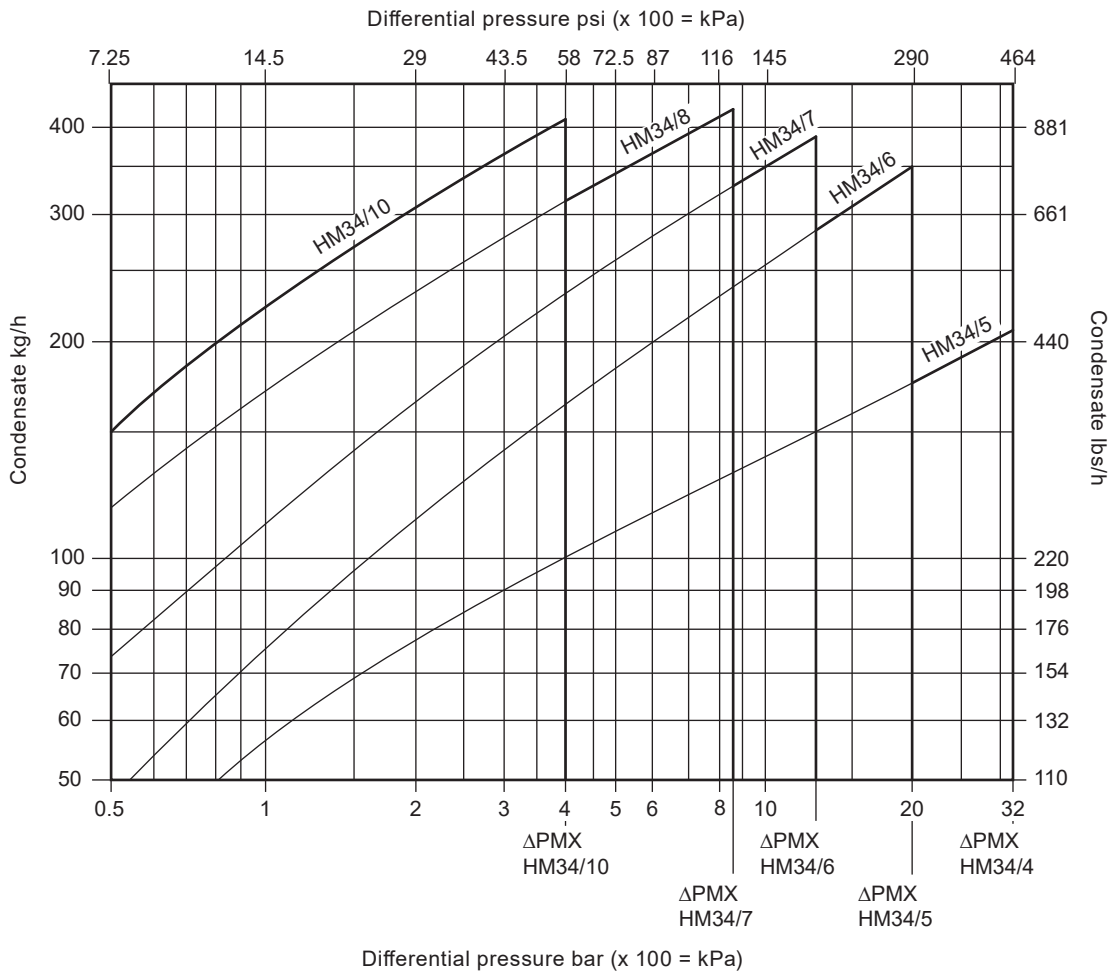

Selection note

Traps should be selected for the most appropriate working pressure differential and not on the basis of load, For example; DN25 HM34 with a load of 80 kg/h (176.3 lbs) at 7 bar (101.5 psi) differential should be handled by an HM34/10 and not an HM34/5.

**1"
DN25**

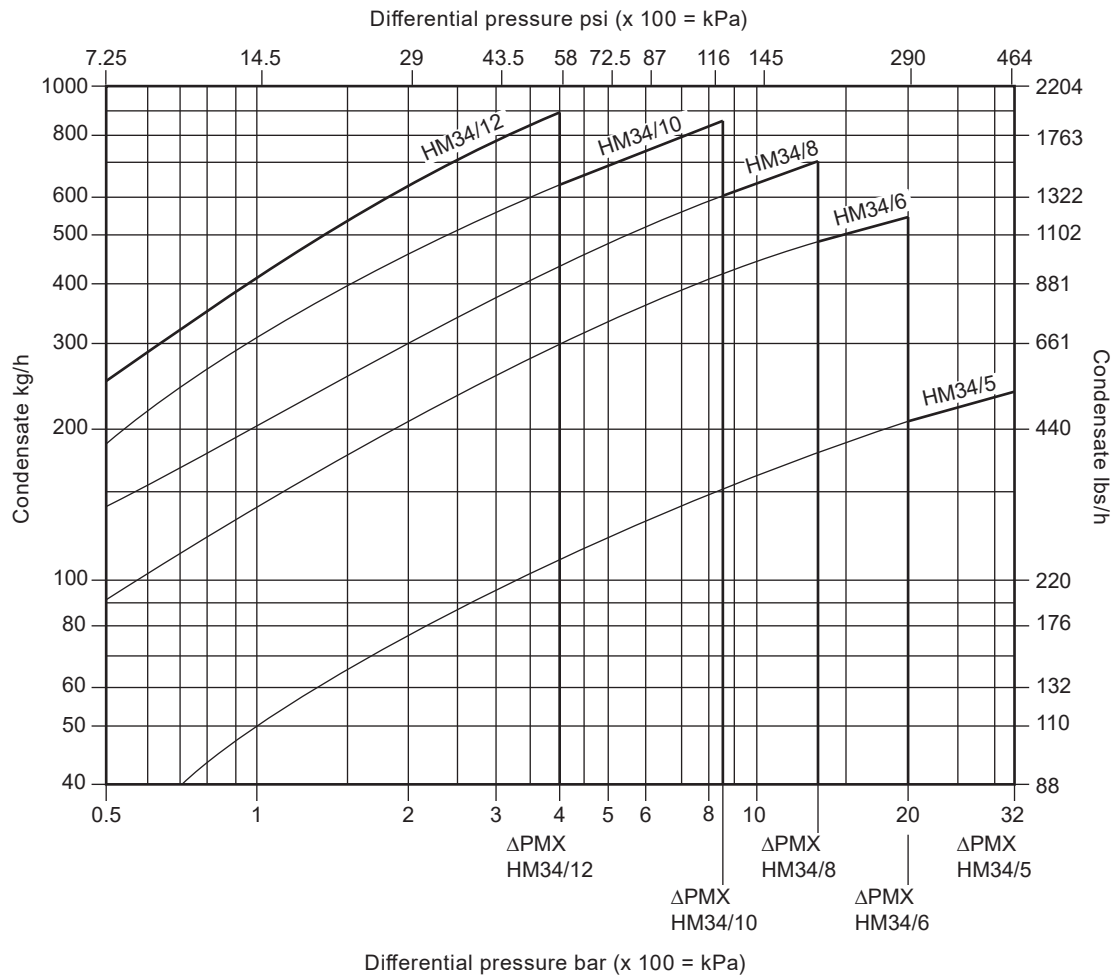

Selection note

Traps should be selected for the most appropriate working pressure differential and not on the basis of load, For example; DN25 HM34 with a load of 80 kg/h (176.3 lbs) at 7 bar (101.5 psi) differential should be handled by an HM34/10 and not an HM34/5.

Dimensions/weights (approximate) in mm (inches) and kg (lbs)

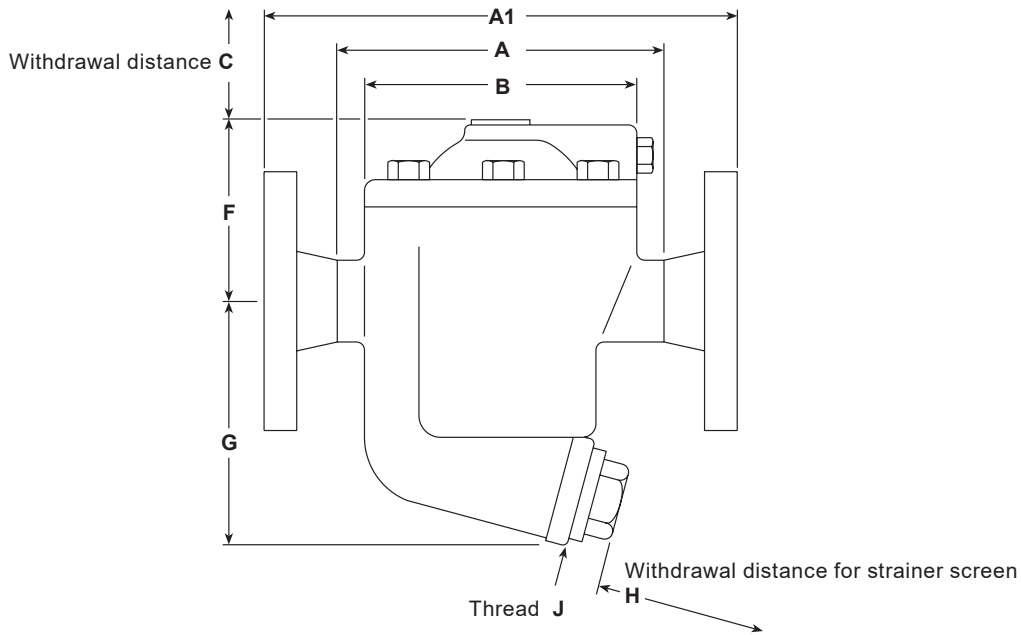

Screwed and socket weld connections

Size	A	B	C	F	G	H	J	Weight
1/2"	120 (4.72)	105 (4.13)	100 (3.94)	67 (2.64)	89 (3.50)	65 (2.56)	M28	2.6 (5.7)
				88 (3.46)	107 (4.21)		M28	4.0 (8.8)
1"	180 (7.09)	160 (6.30)	160 (6.30)	145 (5.71)	120 (4.72)	85 (3.35)	M32	10.4 (22.9)

Flanged connections

Size	A1	B	C	F	G	H	J	Weight
DN15	210 (8.27)	105 (4.13)	100 (3.94)	67 (2.64)	89 (3.50)	65 (2.56)	M28	4.5 (9.9)
				88 (3.46)	107 (4.21)		M28	7.0 (15)
DN25	230 (9.06)	160 (6.30)	160 (6.30)	145 (5.71)	120 (4.72)	85 (3.35)	M32	12.0 (26.5)

Safety information, installation and maintenance

For full details see the Installation and Maintenance Instructions (IM-S03-11) supplied with the product.

Installation note

The trap must be installed with the body upright so that the bucket is rising and falling vertically. The inlet and outlet connections should be in a horizontal plane, with the trap installed below the drain point so that a water seal can be maintained around the open end of the bucket.

Disposal

This product is recyclable. No ecological hazard is anticipated with the disposal of this product providing due care is taken.

How to order

Example: 1 off Spirax Sarco 1/2" HM34/8 inverted bucket steam trap with screwed BSP T Rp (ISO 7-1) connections.

Spare parts

The spare parts available are shown in solid outline. Parts shown in a grey line are not supplied as spares.

Available spares

Valve and seat assembly		5 (2 off), 6, 8, 10
Bucket		4
Cover gasket and ferrule	(packet of 3 each)	7, 11
Strainer screen		12
Strainer screen gasket	(packet of 3 each)	14
Set of cover bolts and nuts	(set of 6)	2

How to order spares

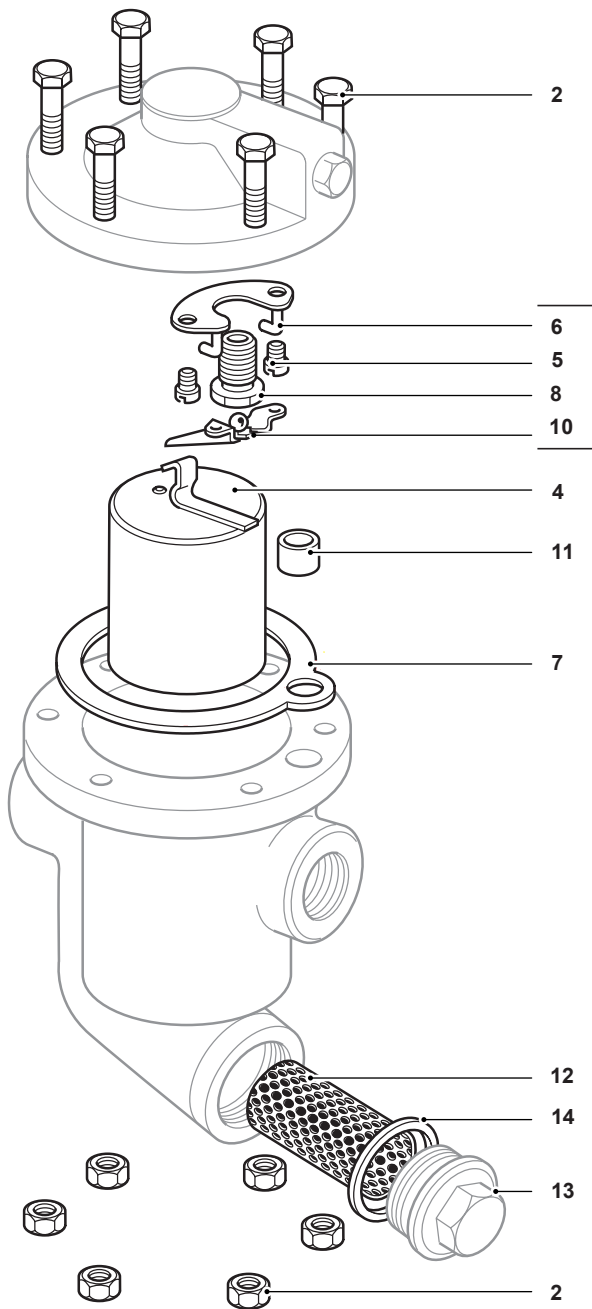

Always order spare parts by using the description given in the column headed 'Available spares' and state the size, type of trap and pressure range.

Example: 1 off Valve and seat assembly for a Spirax Sarco DN25 HM34/7 inverted bucket steam trap.



Valve and seat assembly

Recommended tightening torques

Item	Size	 or  mm	N m	(lbf ft)
2	1/2", 3/4"		M8 x 30	25 - 28 (18-21)
	1"		M12 x 45	25 - 28 (18-21)
8	1/2", 3/4"	13	-	50 - 55 (37-41)
	1"	17	-	80 - 88 (59-65)
13	1/2", 3/4"	22	M28	90 - 100 (66-74)
	1"	27	M32	125 - 145 (92-107)