



Cert. No. LRQ 0963008

ISO 9001

spirax sarco

TI-P337-46
MI Issue 2

Gilflo ILVA Flowmeter DN250 and DN300

Description

The Gilflo ILVA flowmeter operates on the spring loaded variable area principle and produces a differential pressure related to the rate of flow. It can be used with most industrial fluids, gases and both saturated and superheated steam. A general description of the ILVA flowmetering system and its associated equipment is given in a separate TI sheet.

Sizes and pipe connections

DN250 and DN300. For DN50, DN80, DN100, DN150 and DN200 sizes see separate literature.

Suitable for fitting between the following flanges:

EN 1092 PN16, PN25 and PN40.

ASME (ANSI) B 16.5 Class 150, 300 and 600.

JIS 20.

KS 20.

The Gilflo ILVA flowmeter should be installed in pipework manufactured to BS 1600 or ASME (ANSI) B 36.10 Schedule 40. For different pipe standards/schedules, downstream spool pieces with an equivalent internal diameter to BS 1600 or ASME (ANSI) B 36.10 Schedule 40 should be used. If this is not possible, please contact Spirax Sarco Limited.

Materials

Part	Material
Body	Cast stainless steel S.316 (CF8M/1.4408)
Internals	431 S29/S303/S304/S316
Spring	Inconel X750

Pressure/temperature limits

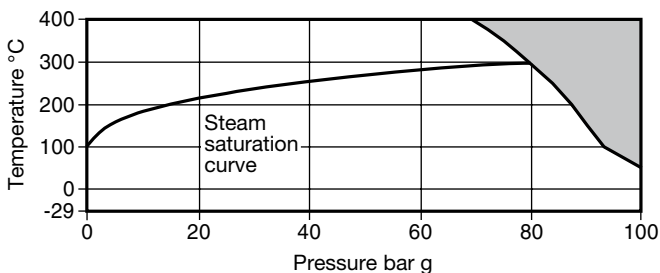

The product **must not** be used in this region.

Body design conditions	ASME (ANSI) 600
PMA Maximum allowable pressure	100 bar g @ 50°C
TMA Maximum allowable temperature	400°C @ 69 bar g
Minimum allowable temperature	-29°C
PMO Maximum operating pressure is dependant on the flange specification	
Minimum operating pressure	0.6 bar g
TMO Maximum operating temperature	400°C @ 69 bar g
Minimum operating temperature	-29°C
Note: For lower operating temperatures consult Spirax Sarco	
Maximum viscosity	30 centipoise
ΔPMX Maximum differential pressure	498 m bar
Designed for a maximum cold hydraulic test pressure of 155 bar g	

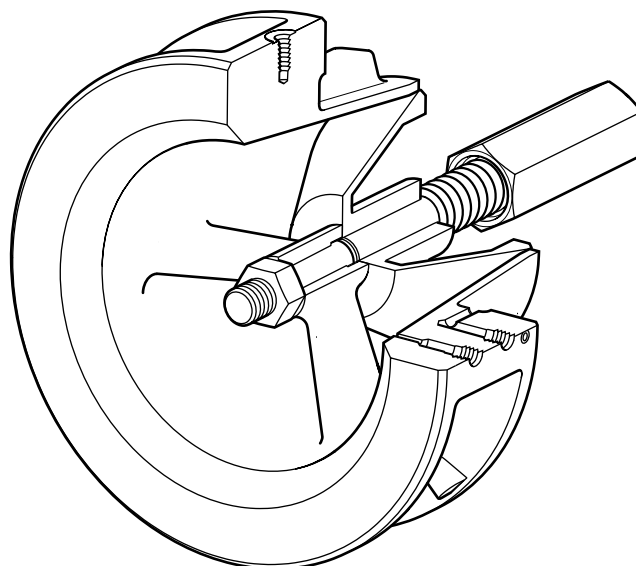

Performance

The Gilflo ILVA is used in conjunction with linearising electronics such as the M800 flow computer or M750 display unit. Alternatively the output signal linearisation can be performed on an EMS/BEMS or equivalent.

Accuracy when used with M800 or M750:

±1% of measured value from 5% to 100% of maximum rated flow.

±0.1% FSD from 1% to 5% of maximum rated flow.

Repeatability better than 0.25%

Turndown: up to 100:1

Caution: The Scanner 2000 mass flow transmitters can be configured at the factory to work with a single, specific Gilflo ILVA flowmeter. For correct operation the configured transmitter must always be installed with its allocated flowmeter. Labels on the packaging give the serial numbers of the matched products.

Pressure drop

The maximum pressure drop across the Gilflo ILVA pipeline unit is 498 m bar (200 ins water gauge) at maximum rated flow.

Flow capacity

To determine the capacity of the Gilflo ILVA for different fluids, it is necessary to calculate the equivalent water flowrate Q_e (in l/min) as described in Step 1, under the section 'sizing the Gilflo ILVA' then selecting the appropriate size of flowmeter from the Table under Step 2 overleaf.

How to order

Example: 1 off Spirax Sarco DN250 Gilflo ILVA flowmeter for installation between EN 1092 PN40 flanges. The body material is to be 316 stainless steel. The flow medium will be saturated steam at 10 bar g and the maximum flow will be 28000 kg/h.

Dimensions/weights (approximate) in mm and kg

Size	A	B	C	D	E	F	Weight
DN250	104	204	444	330	35.0	35	41.5
DN300	120	250	530	385	42.5	35	67.0

Note:- Pressure tapplings are threaded 1/4" NPT

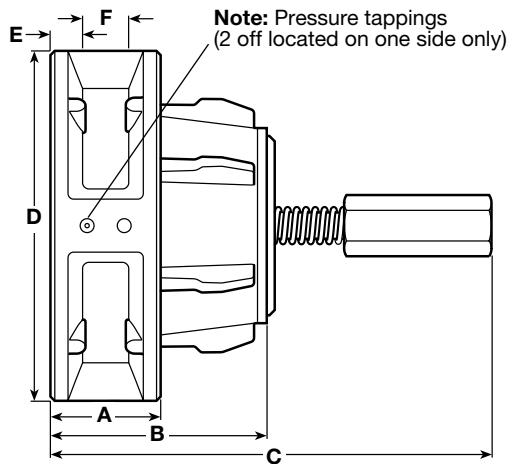

Safety information, installation and maintenance

For full details see the Installation and Maintenance Instructions supplied with the product.

Installation note:

The following main points are given here for guidance:

- The Gilflo ILVA should be mounted with a minimum of 6 straight pipe diameters upstream and 3 downstream. No valves, fittings or cross sectional changes are permitted within these pipe lengths. Where an increase in nominal pipe diameter is required upstream of the flowmeter, the length of straight pipe should be increased to 12 diameters. Similarly, where a Gilflo ILVA is installed downstream of two 90 degree bends in two planes, a pressure reducing valve or a partially open valve, 12 upstream pipe diameters should be allowed.
- It is important that the internal upstream and downstream diameters of pipe are smooth. Ideally seamless pipes should be used. It is recommended that slip-on flanges be used to avoid any intrusive weld beads on the internal diameter of the pipe.
- Care should be taken to install the Gilflo ILVA concentrically in the line. If this is not done, flow measurement errors may occur.
- The Gilflo ILVA should be mounted horizontally. For vertical installations, consult Spirax Sarco.
- For steam applications, good basic steam engineering practices should be followed:
 - Correct line drainage through adequate trapping.
 - Good alignment and support of associated pipework.
 - Line size changes achieved by the use of eccentric reducers.

Maintenance note:

There are no user serviceable parts in the Gilflo ILVA. A visual check together with confirmation that the orifice / cone reference dimension is within tolerance is possible.

Sizing - Gilflo ILVA flowmeter minimum and maximum saturated steam flowrates in kg / h

Notes:

- These capacities are based on a differential pressure across the flowmeter of 498 m bar H₂O (200 Inches).
- Minimum flow is 1% of maximum (100:1 turndown).
- The table below is a guide only.

Size	Q _E	Steam pressure bar g											
		1	3	5	7	10	12	15	20	25	30	40	
DN250	Max.	7750	15985	22185	26915	30899	36043	39099	43292	49541	55155	60325	69758
	Min.	78	160	222	269	309	433	391	433	495	552	603	698
DN300	Max.	10975	22637	31417	38115	43758	51042	55369	61307	70157	78107	85428	98778
	Min.	110	226	314	381	438	510	554	613	702	781	854	988

How to order example: 1 off Spirax Sarco DN250 ILVA flowmeter suitable for fitting between EN 1092 PN16 connections.

Sizing the Gilflo ILVA flowmeter

In order to determine the flow capacity of a Gilflo ILVA pipeline unit, it is necessary to calculate the equivalent water flowrate (Q_E) based on the anticipated actual flow (see Step 1).

The Table below is used to select the appropriate unit (steam only).

Step 1. Determine equivalent water flowrate (Q_E) in l/min:-

	Mass flow units	Volumetric units
Liquids	$Q_E = \frac{q_m}{\sqrt{SG}}$	$Q_E = Q_L \sqrt{SG}$
Gases and steam actual flow conditions	$Q_E = q_M \sqrt{\frac{1000}{D_F}}$	$Q_E = Q_F \sqrt{\frac{D_F}{1000}}$
Gases standard conditions	$Q_E = Q_S \sqrt{\frac{D_S}{1000} \times \frac{P_F}{P_S} \times \frac{T_S}{T_F}}$	$Q_E = Q_S \sqrt{\frac{D_S}{1000} \times \frac{P_S}{P_F} \times \frac{T_F}{T_S}}$

Where:

Q_E = Equivalent water flowrate (litres / min)

q_m = Mass flowrate (kg / min)

Q_L = Maximum liquid flowrate (litres/min)

Q_S = Maximum gas flowrate at standard conditions (litres/min)

Q_F = Maximum gas flowrate at actual flow conditions (litres/min)

SG = Specific gravity

D_S = Density of gas at standard conditions (kg / m³)

D_F = Density of gas at actual flow conditions (kg / m³)

P_S = Standard pressure: 1.013 bar a, 1.033 kg/cm² a, 14.70 psi a

P_F = Actual flow pressure in same absolute units as P_S

T_S = Standard temperature (K) = °C + 273

T_F = Actual flow temperature (K) = °C + 273

Step 2. Using the value of Q_E as determined in Step 1, select the correct size of the Gilflo ILVA flowmeter using the Table below. In practice, it will often be the line size that determines the choice of the flowmeter.

Flowmeter type	Max. Q _E litres / min	Maximum pressure drop Wg
DN250	7750	200
DN300	10975	200

Example: Determine which Gilflo pipeline unit is required to measure the flow of compressed air when:

1: Estimated maximum rate of flow = 28000 s m³ / h at 7 bar g and 20°C.
Note: Standard conditions = 1.013 bar a, 0°C giving a standard density of 1.29 kg / m³

2: Calculate Q_E from:

$$Q_E = Q_S \sqrt{\frac{D_S}{1000} \times \frac{P_S}{P_F} \times \frac{T_F}{T_S}}$$

$$Q_E = (28000 \times 16.667) \times \sqrt{\frac{1.29}{1000} \times \frac{1.013}{8.013} \times \frac{293}{273}}$$

$$Q_E = 6174 \text{ litres / min}$$

So a DN250 ILVA is recommended.

Note: 1 m³ / h = 16.667 litres / min