



FTS62

Stainless Steel Ball Float Steam Traps (DN15 to DN25)

Description

The FTS62 is a stainless steel bodied ball float steam trap having stainless steel working internals and automatic air venting facility.

FTS62 available options when facing the body:

L-R Select L-R for a flow direction of **Left-to-Right**

or



R-L Select R-L for a flow direction of **Right-to-Left**

Optional extra:

On request the cover (2) can be drilled and tapped for the purpose of fitting a balance line.

If this option is requested at the time of order placement there will be an extra charge incurred and the unit will be treated as a special product.

Standards

This product fully complies with the requirements of the EU Pressure Equipment Directive/UK Pressure Equipment (Safety) Regulations and carries the  /  mark.

Certification

This unit is available with certification to EN 10204 3.1.

Note: All certification/inspection requirements must be stated at the time of order placement.

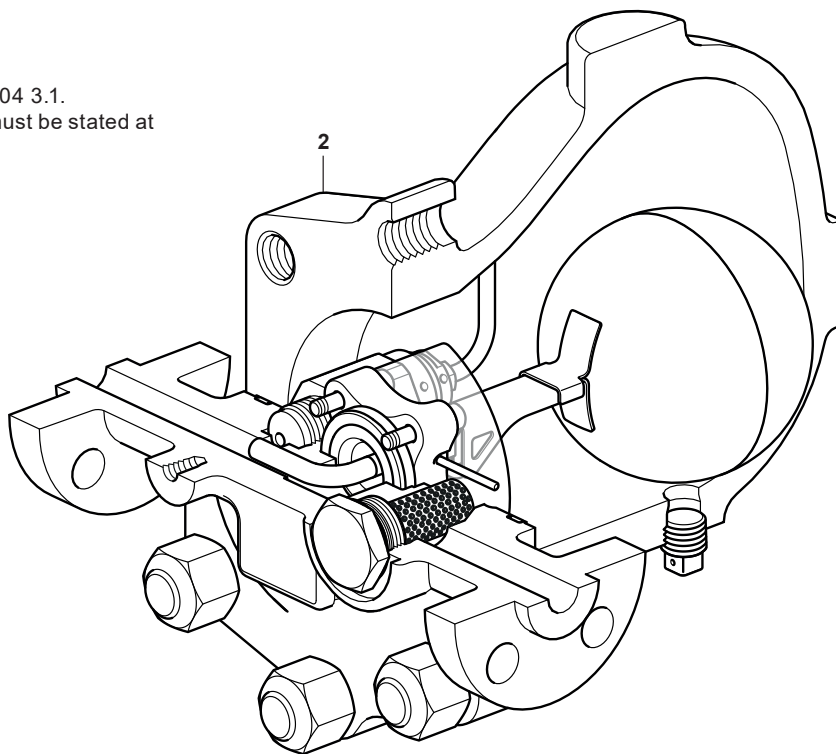

Sizes and pipe connections

1/2", 3/4" and 1"	Screwed BSP or NPT
1/2", 3/4" and 1"	Socket weld ends to BS 3799 and Class 3000 lbs
Standard flanges:	
DN15, DN20 and DN25	Flanged EN 1092-1 PN100 †
1/2", 3/4" and 1"	Flanged ASME B 16.5 Class 600

Note for the PN100 variant:

† The material used for the weld on flange variant is:
Stainless steel 1.4301.

The material used for the studs and nuts upon all versions is

- Studs = ASTM A193 B7
- Nuts = ASTM A194 Gr. 4 to EN 10269

11, 12, 15, 16

* Please note that part numbers 11, 12, 15 and 16 are more clearly identified on the spares illustration on page 6.

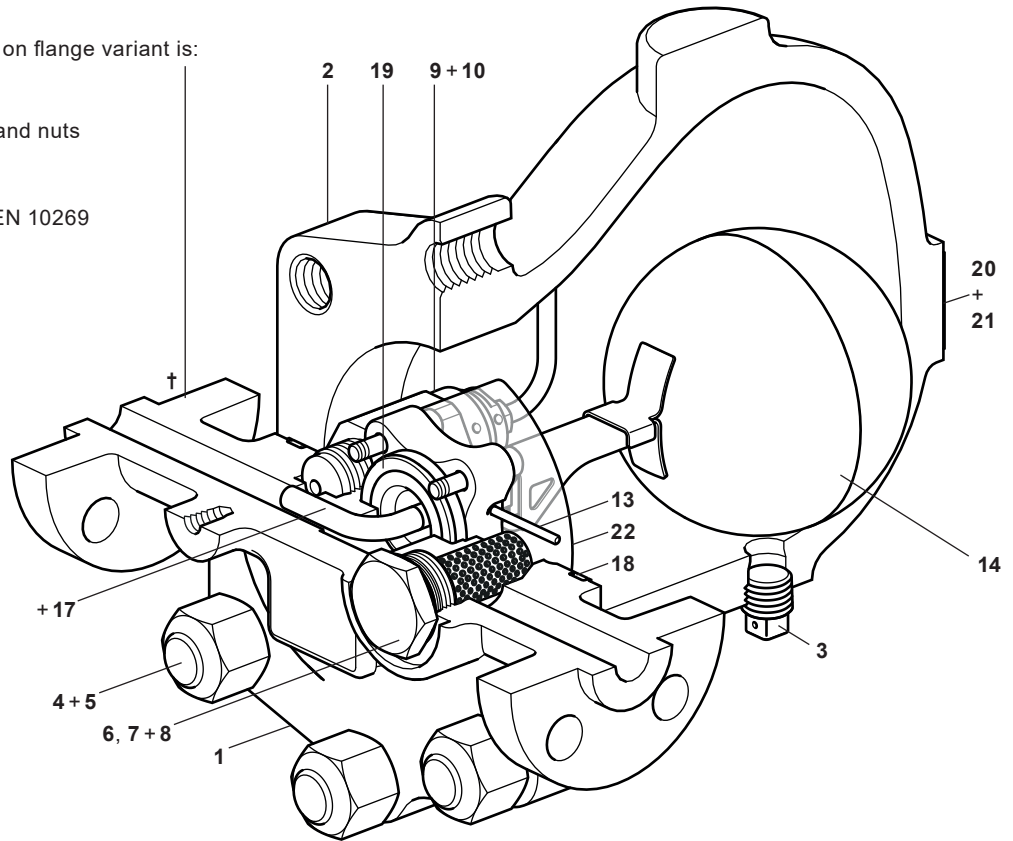

Materials

No.	Part	Material	
1	Body	Stainless steel	ASTM A351 CF8 EN10213 1.4308
2	Cover	Stainless steel	ASTM A351 CF8 EN10213 1.4308
3	3/8" NPT taper plug	Stainless steel	CF8/1.4308 or 1.4301/304
4	3/4" UNF nut (6)	Carbon steel	ASTM A194 Gr. 7
5	3/4" UNF studs x 85mm long (x6)	Carbon steel	ASTM A193 B7
6	Strainer cap	Stainless steel	CF8/1.4308 or 1.4301/304
7	Strainer screen	Stainless steel	AISI 316L
8	'S' type gasket	Stainless steel	AISI 304
9	Air vent assembly	Stainless steel	AISI 431 S29 + 303
10	Air vent tube	Stainless steel	ASTM A269 304L
11*	Seat clamp	Stainless steel	CF8/1.4308 or AISI 303
12*	M6x30 long cap screw (x4)	Stainless steel	EN 150 3506-1
13	Pivot pin	Stainless steel	ASTM A276 304
14	Float assembly	Stainless steel	AISI 304L
15*	1/2" Ø ball	Stainless steel	AISI 316
16*	Conical spring	Stainless steel	Gr. 302 S26 Gr. 1
17	Valve seat and discharge pipe assembly	Stainless steel	AISI 431 S29 + 304L
18	Spirally wound gaskets	Body to Cover and Seat to Body	Graphite filler + 304 stainless strip
19			
20	Name-plate	Stainless steel	204
21	Hammer drive screws (x 2)	Stainless steel	18-8
22	Baffle plate	Stainless steel	304L

Pressure/temperature limits (ISO 6552)

Screwed Socket weld

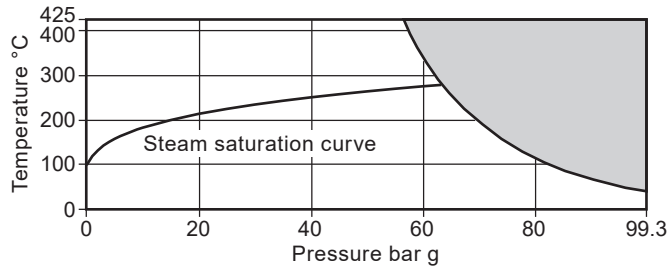

The product must not be used in this region or beyond the parameter of the PMA or TMA of the relative end connection.

Body design condition	ASME Class 600
PMA Maximum allowable pressure	99.3 bar g @ 38 °C
TMA Maximum allowable temperature	425 °C @ 56 bar g
Minimum allowable temperature	-29 °C
PMO Maximum operating pressure for saturated steam service	63.1 bar g @ 280 °C
TMO Maximum operating temperature	425 °C @ 56 bar g
Minimum operating temperature Note: For lower operating temperatures consult Spirax Sarco	0 °C
Minimum operating differential pressure	0.1 bar g
Δ PMX Maximum differential pressure	FTS62-46 46 bar
	FTS62-62 62 bar
Designed for a maximum cold hydraulic test pressure of:	149 bar g

Flanged PN100

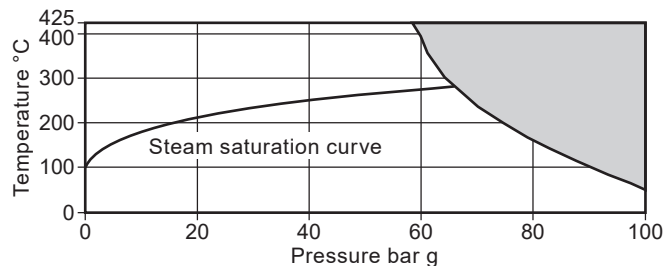

The product must not be used in this region or beyond the parameter of the PMA or TMA of the relative end connection.

Body design condition	PN100
PMA Maximum allowable pressure	100 bar g @ 50 °C
TMA Maximum allowable temperature	425 °C @ 58.9 bar g
Minimum allowable temperature	-29 °C
PMO Maximum operating pressure for saturated steam service	65.8 bar g @ 283 °C
TMO Maximum operating temperature	425 °C @ 58.9 bar g
Minimum operating temperature Note: For lower operating temperatures consult Spirax Sarco	0 °C
Minimum operating differential pressure	0.1 bar g
Δ PMX Maximum differential pressure	FTS62-46 46 bar
	FTS62-62 62 bar
Designed for a maximum cold hydraulic test pressure of:	150 bar g

Pressure/temperature limits (ISO 6552) - Flanged ASME

Flanged ASME Class 600

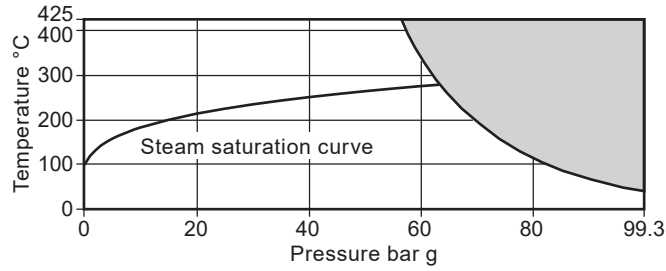

The product must not be used in this region or beyond the parameter of the PMA or TMA of the relative end connection.

Body design condition	ASME Class 600	
PMA Maximum allowable pressure	99.3 bar g @ 38 °C	
TMA Maximum allowable temperature	425 °C @ 56 bar g	
Minimum allowable temperature	-29 °C	
PMO Maximum operating pressure for saturated steam service	63.1 bar g @ 280 °C	
TMO Maximum operating temperature	425 °C @ 56 bar g	
Minimum operating temperature Note: For lower operating temperatures consult Spirax Sarco	0 °C	
Minimum operating differential pressure	0.1 bar g	
ΔPMX Maximum differential pressure	FTS62-46	46 bar
	FTS62-62	62 bar
Designed for a maximum cold hydraulic test pressure of:	149 bar g	

Capacities

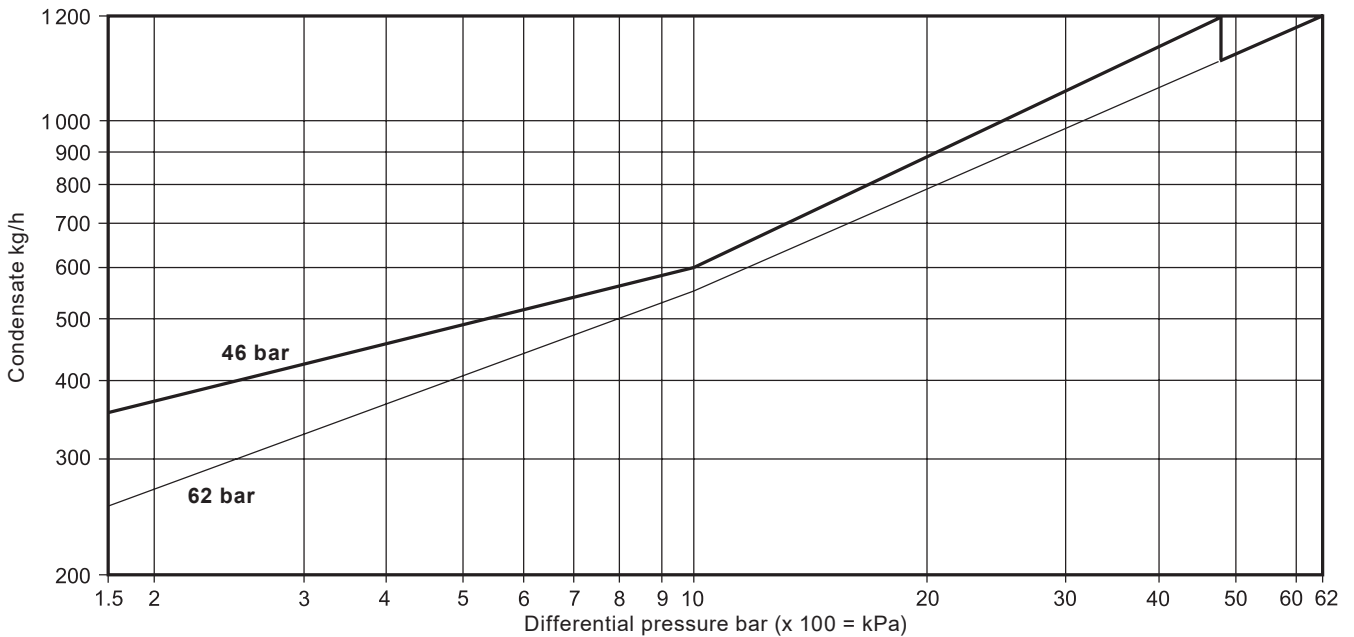

Capacities shown above are based on condensate at saturation temperature. Under start-up conditions when condensate is cold the internal bi-metallic air vent will be open and provides additional capacity to the main valve. The following table gives the minimum additional cold water capacities from the air vent on all sizes.

Note: The air vent closing temperature range = 120 °C to 135 °C.

For differential pressures less than 1.5 bar g, the additional cold water capacity is minimal.

ΔP (bar)	1.5	10	30	46	62
FTS62	Minimum additional cold water capacity (kg/h)				
46 bar version	20	426	536	800	
62 bar version	20	350	440	930	800

Dimensions/weights (approximate) in mm and kg

Size	Flanged						Screwed and Socket weld			Common sizes			
	PN100			ASME 600			A	B	Weight	C	D	E	F
	A	B	Weight	A	B	Weight							
DN15	300	304.0	25.0	261	299	24.0	190	287.5	22.0	172.5	148	251.5	239
DN20	300	316.5	26.0	271	309	25.5	190	287.5	22.0	172.5	148	251.5	239
DN25	300	321.5	28.0	291	314	27.0	190	287.5	22.0	172.5	148	251.5	239

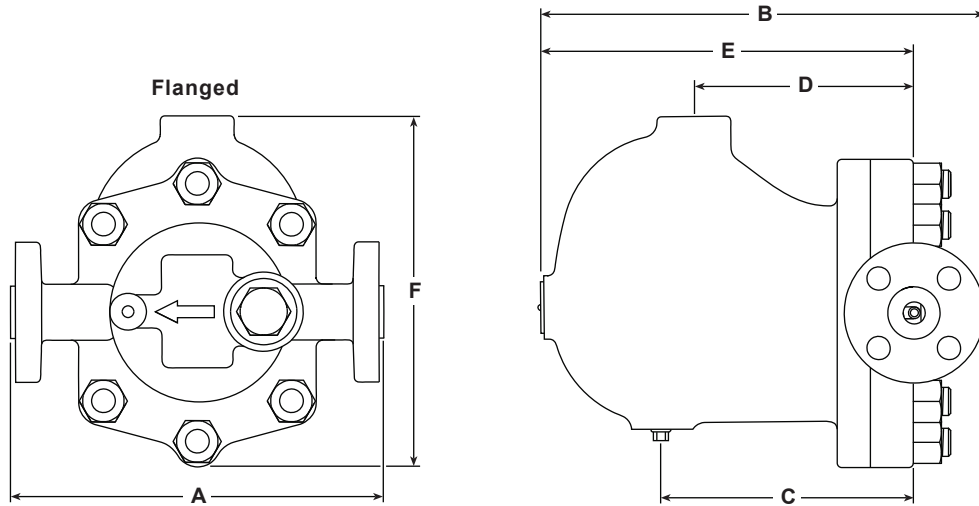

Notes: 1. PN100 EN 1092-1 and ASME 600 B 16.5 face-to-face dimensions

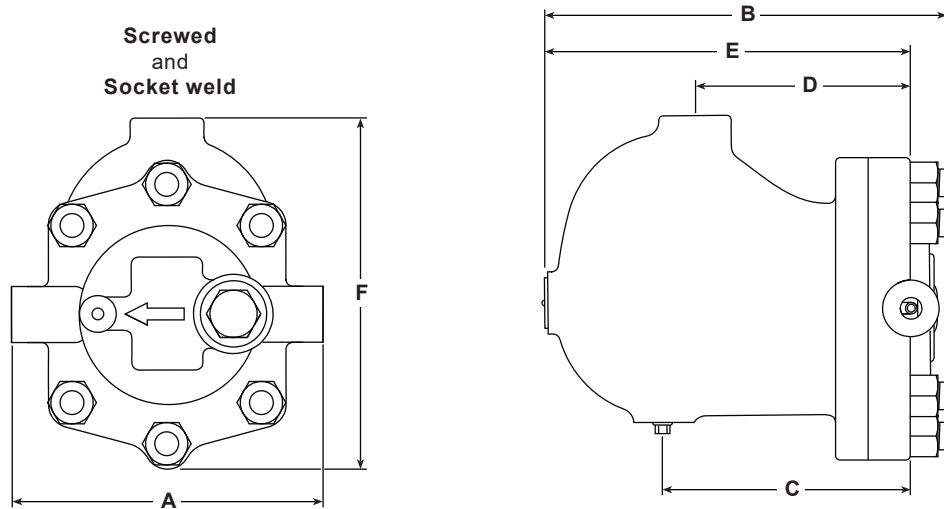

Safety information, installation and maintenance

For full details see the Installation and Maintenance Instructions (IM-P179-15) supplied with the product.

Installation note:

The FTS62 must be installed with the direction of flow as indicated on the body, and with the float arm in a horizontal plane so that it rises and falls vertically.

Disposal

This product is recyclable. No ecological hazard is anticipated with the disposal of this product, providing due care is taken.

How to order

Example: 1 off Spirax Sarco DN25 FTS62-62 L-R ball float steam trap, flanged to EN 1092 PN100 with stainless steel body and cover and thermostatic air vent.

Spare parts

The spare parts available are shown in solid outline. Parts drawn in a grey line are not supplied as spares.

Available spares

Body/cover gasket kit	18
Air vent assembly + Air vent tube	9 and 10
Strainer screen + 'S' type gasket	7 and 8
	3
	12
	13
	14
Maintenance kit	15
	16
	17
	8, 18 and 19
	22
Overhaul kit	3, 7, 8, 9, 10, 12, 13, 14, 15, 16, 17, 18, 19 and 22

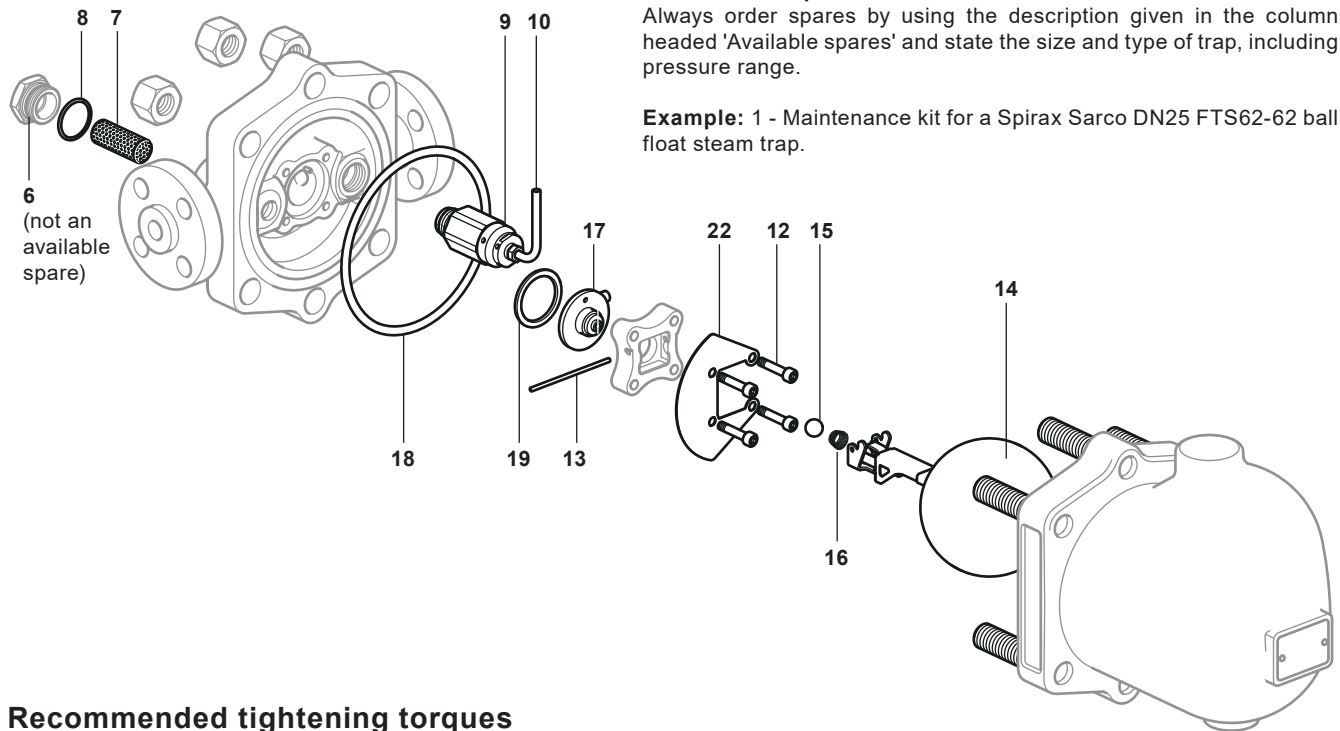



How to order spares

Always order spares by using the description given in the column headed 'Available spares' and state the size and type of trap, including pressure range.

Example: 1 - Maintenance kit for a Spirax Sarco DN25 FTS62-62 ball float steam trap.

Recommended tightening torques

Item	Part		inch or mm		N m	lbf ft
3	3/8" NPT Square head plug		11 mm A/F	3/8" NPT	As required	
4	3/4" UNF Hex. Nut		1.125" A/F	3/4" UNF	252-260	186 - 192
6	Strainer cap		32 mm A/F	M28 x 1.5	170-190	125-140
9	Air vent assembly		32 mm A/F	M22 x 1.5	80-88	59-65
10	Air vent tube assembly		11 mm A/F	M10 x 1.5	10-12	7-9
12	M6 x 30 Socket head cap screw		5 A/F (Hex Key)	M6	14-16	10-12

