



FTGS14

Ball Float Steam Trap (Screwed)

Description

The FTGS14 ball float steam trap has an austenitic stainless steel body, stainless steel working internals and integral automatic air venting facility. The SG iron cover is electroless nickel-plated offering increased resistance to erosion. The FTGS14 can be maintained without disturbing the pipework.

Available options	FTGS14 (R-L)	Horizontal connections with flow from right to left
	FTGS14 (L-R)	Horizontal connections with flow from left to right
	FTGS14V	Vertical connections with flow from top to bottom

Capsule

The BP99/32 capsule which is used in the FTGS14 is suitable for use on 150 °C superheat @ 0 bar g and 50 °C superheat @ 32 bar g.

Optional extras

A **manually adjustable needle valve** (designated 'C' on the nomenclature i.e. **FTGS14-C**) can be fitted to the trap. This option provides a **steam lock release (SLR)** feature in addition to the standard air vent. For further information please consult Spirax Sarco.

An **integral strainer screen** (designated 'X' on the nomenclature i.e. **FTGS14X**) can be fitted to the trap. For further information please consult Spirax Sarco.

Standards

This product fully complies with the requirements of the European Pressure Equipment Directive 2014/68/EU.

Certification

This product is available with a manufacturers Typical Test Report.

Note: All certification/inspection requirements must be stated at the time of order placement.

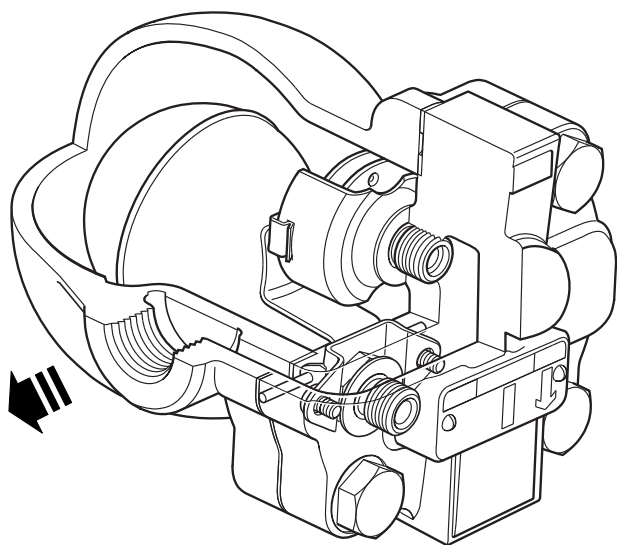

FTGS14 (R-L)

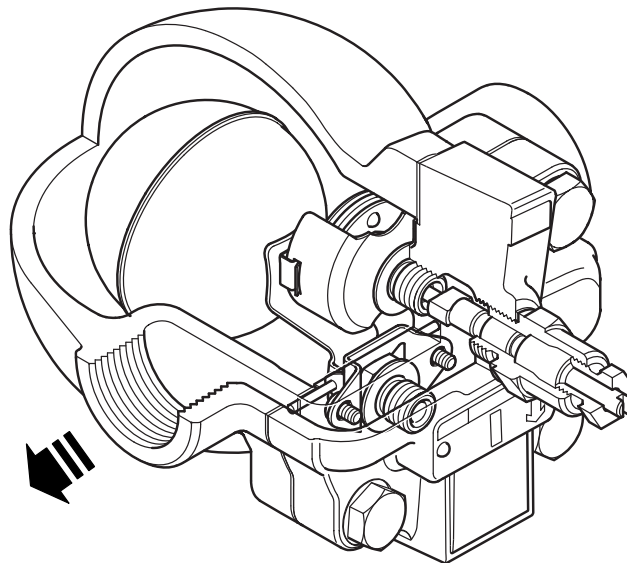

FTGS14-C (R-L)
(with optional SLR)

Sizes and pipe connections

½", ¾" and 1" screwed BSP T Rp (ISO 7-1) and NPT.

Pressure/temperature limits (ISO 6552)

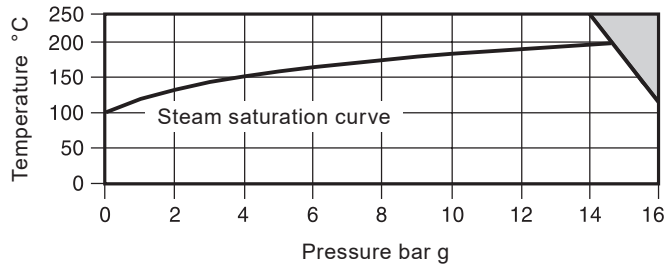

The product **must not** be used in this region.

Body design conditions		PN16	
PMA	Maximum allowable pressure	16 bar g @ 120 °C	
TMA	Maximum allowable temperature	250 °C	
Minimum allowable temperature		-10 °C	
PMO	Maximum operating pressure for saturated steam service	14.6 bar g	
TMO	Maximum operating temperature	250 °C @ 13.8 bar g	
Minimum operating temperature		0 °C	
	FTGS14-4.5	4.5 bar	
ΔPMX	Maximum differential pressure	FTGS14-10	10 bar
		FTGS14-14	14 bar
Product is safe for use under full vacuum conditions			
Designed for a maximum cold hydraulic test pressure of:		24 bar g	

Materials

FTGS14 (R-L)

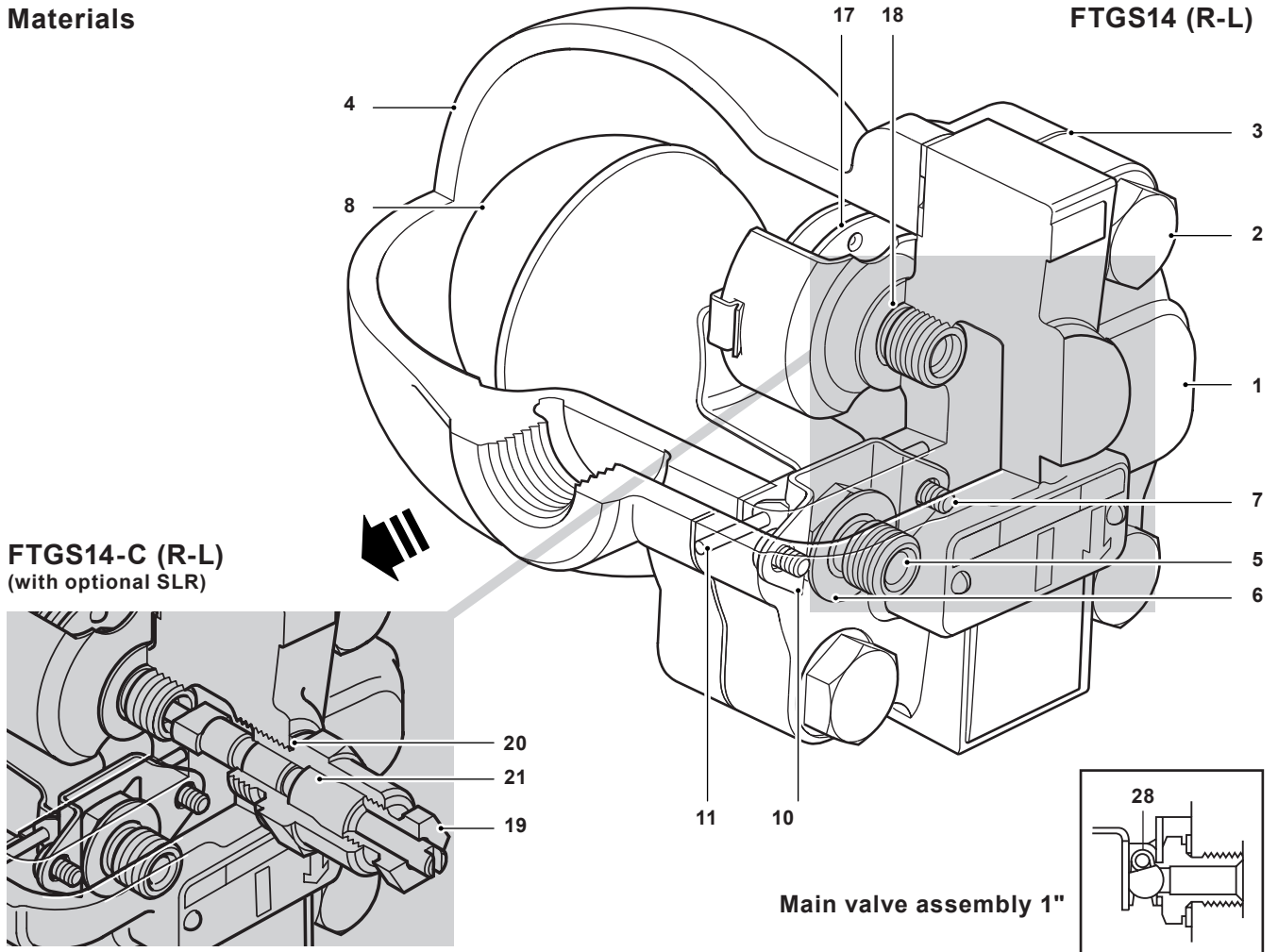

No.	Part	Material	
1	Body	Austenitic stainless steel	EN 10213-4 (1.4308) ASTM A351 CF8
2	Cover bolts	Steel	
3	Cover gasket	Reinforced exfoliated graphite	
4	Cover	Electroless nickel plated SG iron	DIN 1693 GGG 40
5	Valve seat	Stainless steel	
6	Valve seat gasket	Stainless steel	
7	Pivot frame assembly screws	Stainless steel	
8	Ball float and lever	Stainless steel	
10	Pivot frame	Stainless steel	
11	Pivot pin	Stainless steel	
17	Air vent assembly	Stainless steel	
18	Air vent seat gasket	Stainless steel	
19	SLR assembly	Stainless steel	
20	SLR gasket	Stainless steel	
21	SLR seal	Graphite	
28	Valve spring (1" only)	Stainless steel	

Note: Due to regional manufacturing differences some standard versions may be supplied with a 'C' type body with a stainless steel plug and gasket. If this configuration is specifically required it must be specified at the time of order placement.

Capacities

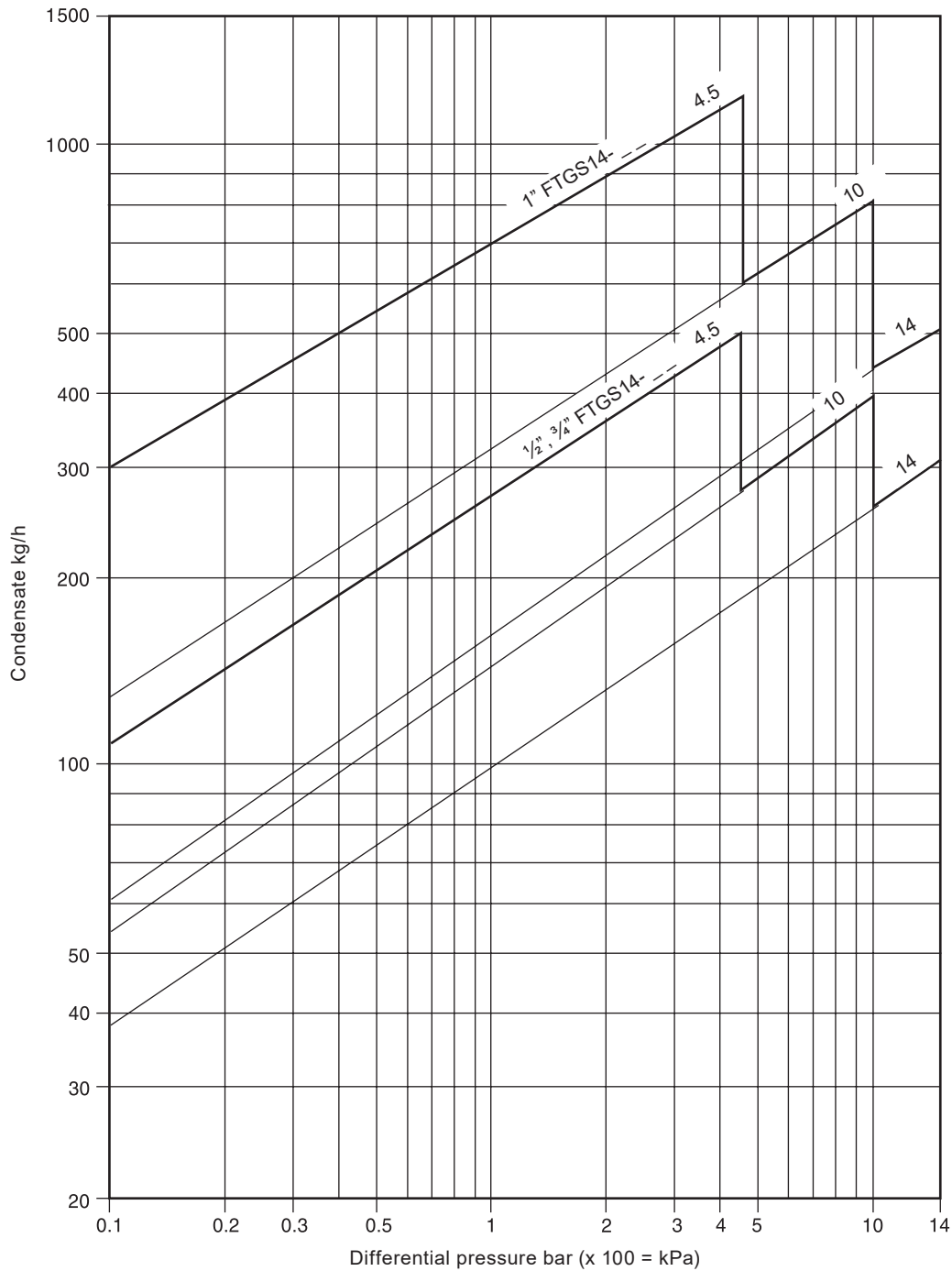

Additional cold water capacities from the thermostatic air vent under start-up conditions

Capacities shown above are based on condensate at saturation temperature. Under start-up conditions when the condensate is cold the internal thermostatic air vent will be open and provides additional capacity to the main valve. The following table gives the minimum additional cold water capacities from the air vent.

ΔP (bar)	0.5	1	2	3	4.5	7	10	14
	Minimum additional cold water capacity (kg/h)							
1/2" and 3/4"	70	140	250	380	560	870	1 130	1 500
1"	120	240	360	500	640	920	1 220	1 500

Dimensions/weights (approximate) in mm and kg

Size	A	B	B1	C	D	E Withdrawal distance	F	Weight
½" and ¾"	123	107	96	70	150	105	38	3.4
1"	145	107	117	70	160	120	38	4.6

FTGS14

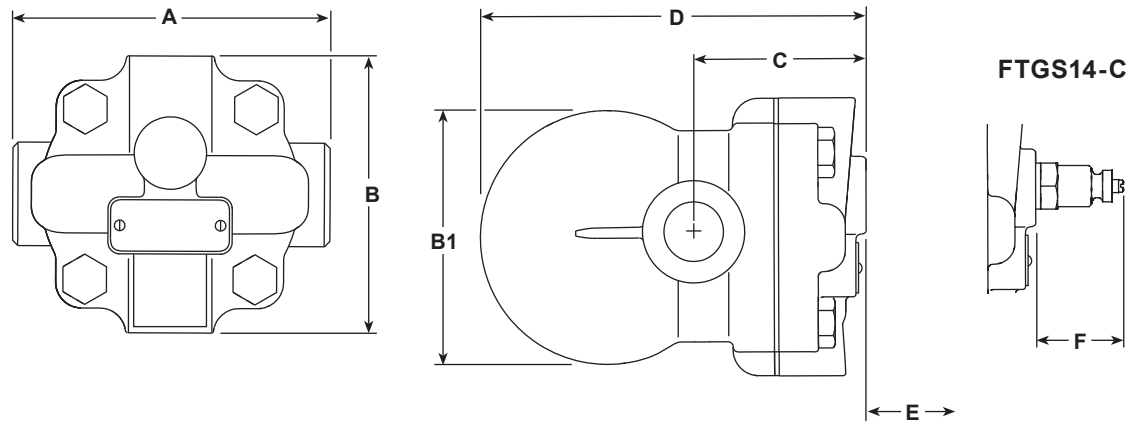

Safety information, installation and maintenance

For full details see the Installation and Maintenance Instructions (IM-P145-12) supplied with the product.

Installation note

The FTGS14 must be installed with the direction of flow as indicated on the body and the arrow on the nameplate must point downwards with the float arm in a horizontal plane so that it rises and falls vertically. If required the flow orientation can be changed on site.

Disposal

This product is recyclable. No ecological hazard is anticipated with the disposal of this product providing due care is taken.

How to order

Example: 1 off Spirax Sarco ½" FTGS14-4.5 (L-R) ball float steam trap with screwed BSP connections and integral air vent.

Spare parts

The spare parts available are shown in solid outline. Parts drawn in a grey line are not supplied as spares.

Available spares

Maintenance kit	3, 5, 6, 7 (2 off), 8, 10, 11, 17, 18, 28 (1" only)
Main valve assembly with float	3, 5, 6, 7 (2 off), 8, 10, 11, 28 (1" only)
Air vent assembly	3, 17, 18
Manually adjustable needle valve (FTGS14-C only)	19 + 21, 20
Cover gasket (packet of 3)	3



How to order spares

Always order spares by using the description given in the column headed 'Available spares' and state the size, type of trap and pressure range.

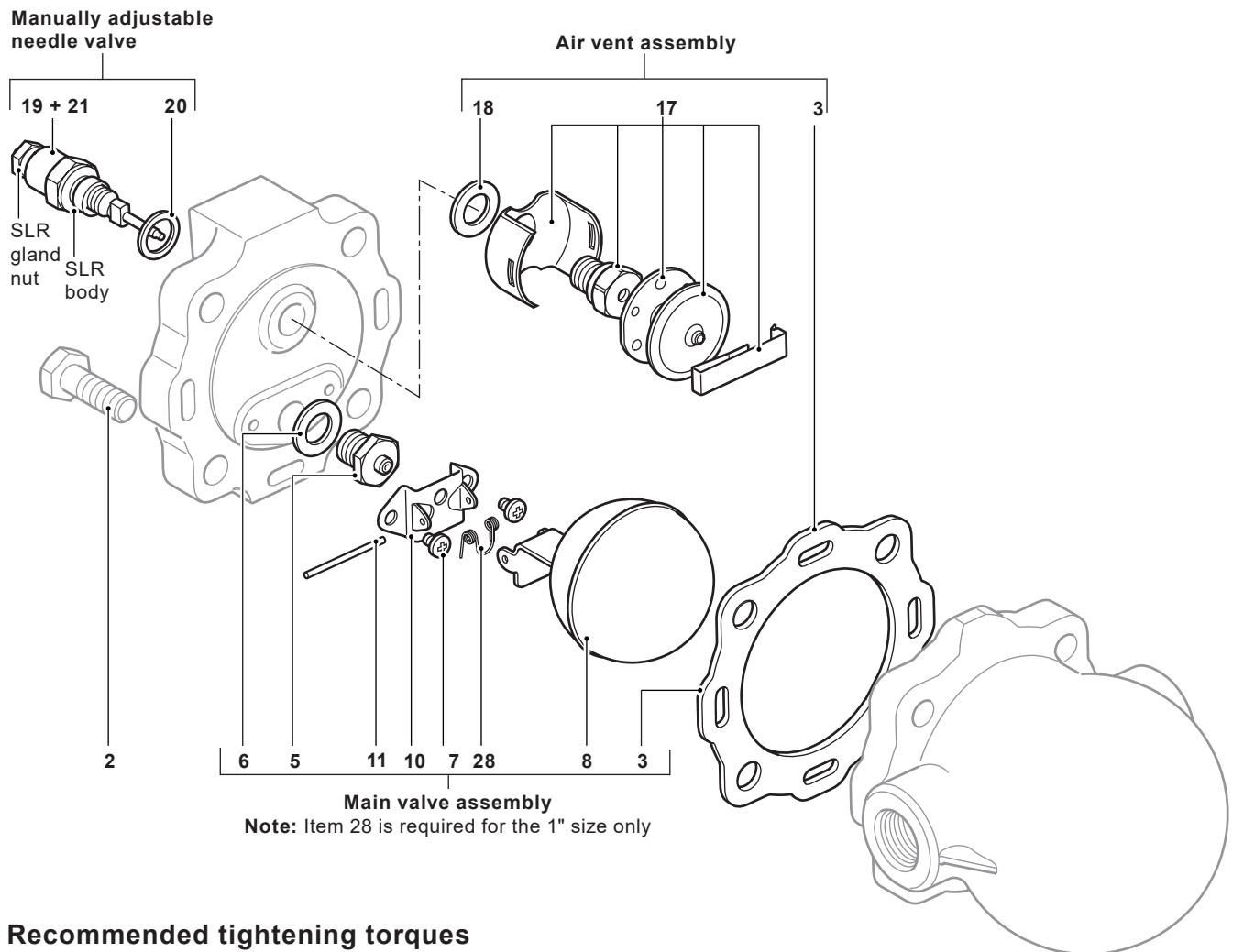
Example: 1 - Main valve assembly for a Spirax Sarco ½" FTGS14-10 ball float steam trap.



Recommended tightening torques

Item	Part	 or 	mm	N m	lbf ft	
2	Cover bolts		17 mm A/F	M10 x 30	47 - 50	35 - 37
5	Main valve seat		17 mm A/F		50 - 55	37 - 40
7	Main valve assembly screws		Pozidrive	M4 x 6	2.5 - 3.0	1.8 - 2.2
17	Air vent assembly		17 mm A/F		50 - 55	37 - 40
19	SLR body		19 mm A/F		57 - 63	42 - 46
	SLR gland nut		13 mm A/F		3 - 5	2.2 - 3.7