

spirax sarco

FT57

SG Iron

Ball Float Steam Trap with Flanged Connections

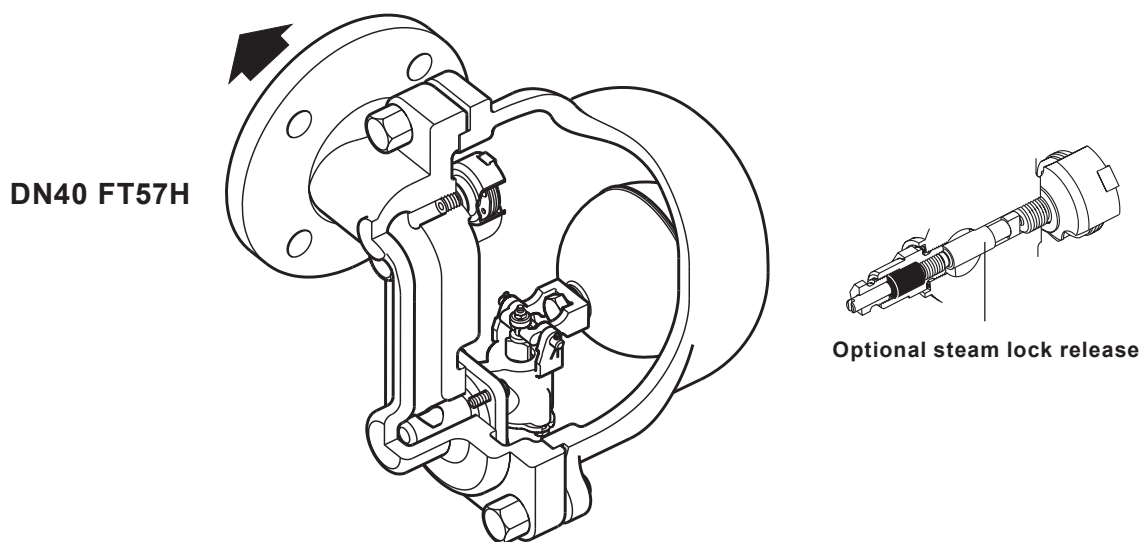

Description

The FT57 is an SG iron ball float steam trap with internal thermostatic air vent for the prompt removal of large condensate loads from steam systems. The trap is supplied with integrally flanged connections (for horizontal installation) and can be maintained without disturbing the pipework. Body and cover are produced by TÜV approved foundries. For further information see TI-P603-05.

Available options

FT57H - Horizontal flow.

Standards

These products fully comply with the requirements of the EU Pressure Equipment Directive/UK Pressure Equipment (Safety) Regulations and carries the **CE** mark when so required.

Certification

This product is available with certification to EN 10204 3.1.

Note: All certification/inspection requirements must be stated at the time of order placement.

Sizes and pipe connections

DN15, DN20, DN25, DN40 and DN50.

Standard flange EN 1092 PN40 (formerly DIN 2501).

Face-to-face dimensions to BS EN 26554 Series 1.

Optional extras

Manually adjustable needle valve (designated 'C' on the nomenclature) can be fitted to all versions. This option provides a **steam lock release** feature in addition to the standard air vent.

The cover can be drilled and tapped for the purpose of fitting a balance line and drain cock if requested at the point of order.

Materials

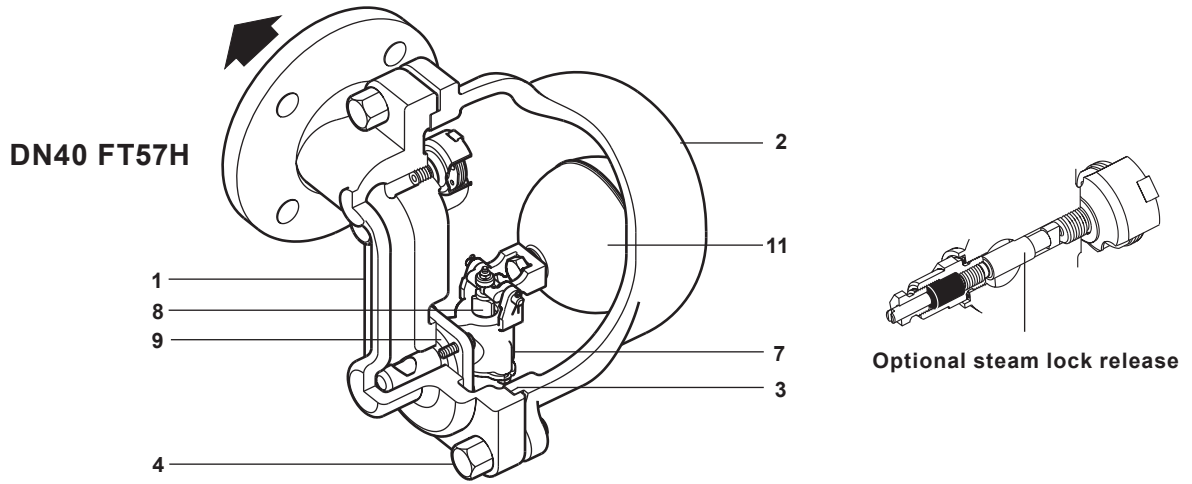

No.	Part	Material	
1	Body	SG iron	EN-GJS-400-18U-LT
2	Cover	SG iron	EN-GJS-400-18U-LT
3	Cover gasket	Reinforced exfoliated graphite	
4	Cover bolts	Steel	25 CrMo 4 (1.7218)
5	Valve seat	DN15-DN25	Stainless steel X 22 CrNi 17 2 (1.4057)
6	Valve	DN15-DN25	Stainless steel X 105 CrMo 17 (1.4125)
7	Valve seat	DN40-DN50	Stainless steel X 22 CrNi 17 2 (1.4057)
8	Valve	DN40-DN50	Stainless steel X 22 CrNi 17 2 (1.4057)
9	Main valve gasket	Exfoliated graphite	
10	Ball float	Stainless steel	X 5 CrNi 18 10 (1.4301)
11			

Note: All other internals are manufactured in stainless steel.

Dimensions/weights (approximate) in mm and kg

Size	A	B	C	D	E	Weight
DN15	150	48	126	151	119	7.5
DN20	150	53	126	151	119	8.0
DN25	160	58	126	151	119	8.5
DN40	230	75.5	192	208	168	27.0
DN50	230	83	192	208	168	28.0

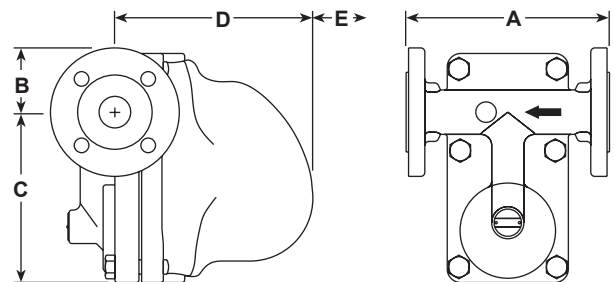

FT57H DN15 - DN50

ΔPMX - Maximum differential pressures

Size and model	FT57H-4	FT57H-4.5	FT57H-8	FT57H-10	FT57H-12	FT57H-20	FT57H-28	FT57H-32
DN15, DN20 and DN25	4 bar	-	8 bar	-	12 bar	20 bar	-	32 bar
DN40 and DN50	-	4.5 bar	-	10 bar	-	-	28 bar	-

Pressure/temperature limits

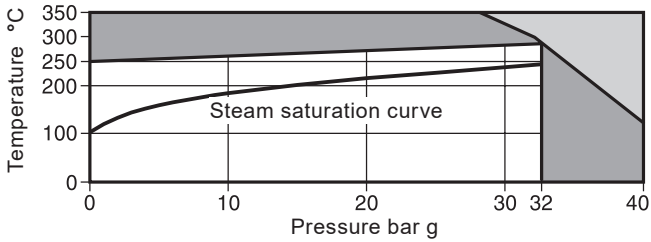

- The product **must not** be used in this region.
- The product should not be used in this region or beyond its operating range as damage to the internals may occur.

Body design conditions		PN40
PMA	Maximum allowable pressure	40 bar g @ 120 °C
TMA	Maximum allowable temperature	350 °C @ 28 bar g
Minimum allowable temperature		-10 °C
PMO	Maximum operating pressure for saturated steam service	32 bar g
TMO	Maximum operating temperature	287 °C @ 32 bar g
Minimum operating temperature		0 °C
Note: For lower operating temperatures consult Spirax Sarco		
ΔPMX	Maximum differential pressures	See overleaf
Designed for a maximum cold hydraulic test pressure of:		60 bar g

Caution: The trap in its complete operational form must not be subjected to a pressure of greater than 48 bar otherwise damage to the internal mechanism may result.

Capacities (in accordance with ISO 7842)

Capacities shown are based on boiling hot condensate.

DN15, DN20 and DN25

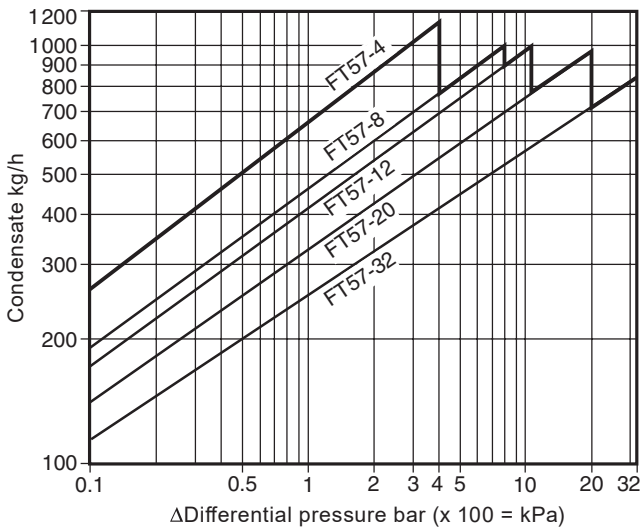

DN40 and DN50

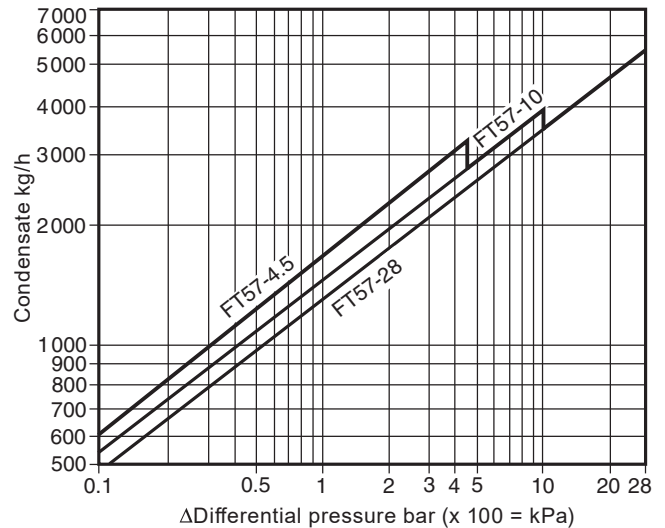

Additional cold water capacities from thermostatic air vent under start-up conditions

Under start-up conditions when the condensate is cold the internal thermostatic air vent will be open and provides additional capacity to the main valve. The Table below gives the minimum additional cold water capacities from the air vent.

Minimum additional cold water capacities from the air vent (kg/h)

Pressure (bar)	0.5	1	2	3	4	4.5	8	10	12	16	20	28	32
DN15, DN20 and DN25	460	680	900	1080	1250	-	1700	-	2000	2250	2550	-	3000
DN40 and DN50	460	680	900	1080	-	1300	1700	1900	-	2250	2550	2900	-

How to order

Example: 1 off Spirax Sarco DN40 FT57H-4.5 ball float steam trap with SG iron body and cover. Flanged connections to EN 1092 PN40. Trap to be fitted with the optional balance and drain connections.

Note: If the product has the optional steam lock release fitted the nomenclature would be FT57-4.5-C.

Safety information, installation and maintenance

For full details see the Installation and Maintenance Instructions (IM-P603-03) supplied with the product.

Installation note

The trap is designed for installation with the float arm in a horizontal plane so that it rises and falls vertically, ideally with a drop leg immediately preceding the trap. Suitable isolation valves must be installed to allow for safe maintenance/replacement. Where steam traps are fitted in exposed conditions, the possibility of freezing damage may be reduced by thermal insulation/drainage/isolation.

Maintenance note



Maintenance can be completed with the trap in the pipeline, once the safety procedures have been observed. It is recommended that new gaskets and spares are used whenever maintenance is undertaken.

Caution: The cover gasket and main valve assembly gasket may contain a thin stainless steel support ring which may cause physical injury if it is not handled and disposed of carefully.

Disposal

No ecological hazard is anticipated with the disposal of this product provided due care is taken.

Recommended tightening torques

Item No.	Part	 or 	mm	N m		
4	DN15, DN20 and DN25	FT57H	Bolt	10 (socket)	M12 x 35	70 - 75
		FT57V	Stud		M12	35 - 40
			Nut	19 A/F	M12	70 - 75
	DN40 and DN50	FT57H	Bolt	24 A/F	M16 x 55	150 - 165
		FT57V	Stud		M16	70 - 80
			Nut	24 A/F	M16	150 - 165
5	Valve seat		17 A/F	M12	50 - 55	
14	Valve bolts		10 A/F	M6 x 10	10 - 12	
16	Erosion deflector bolts		10 A/F	M6 x 10	10 - 12	
17	Air vent seat		17 A/F		50 - 55	
19	(SLR sub-assembly)		19 A/F		40 - 45	
21	(SLR retaining nut)		13 A/F		4 - 5	

Spare parts

The spare parts available are shown in heavy outline. Parts shown in grey line are not supplied as spares.

Available spares

Main valve assembly with float (DN15, 20 and 25)	5, 6, 10, 12, 13, 14, 15
Main valve assembly with erosion deflector (DN40 and 50)	7, 8, 9, 16
Ball float (DN40 and 50 only)	11
Air vent assembly	17, 18
Complete set of gaskets (packet of 3)	3, 9, 18, 20
Steam lock release and air vent assembly	17, 18, 19, 20, 21, 22, 23

How to order spares

Always order spare parts by using the description given in the column headed 'Available spares' and state the size, Model No., orientation i.e. horizontal (H) or vertical (V) and pressure rating of the trap.

Example: 1 - Main valve assembly for a DN40 FT57H-4.5 ball float steam trap. For operating pressures up to 4.5 bar.

Note: If the product has the optional steam lock release fitted the nomenclature would be FT57H-4.5-C.

FT57H shown

