



FT44 Carbon Steel Ball Float Steam Traps (DN15 to DN50)

Description

The FT44 is a carbon steel bodied ball float steam trap having stainless steel working internals and automatic air venting facility. The body and cover castings are produced by a TÜV approved foundry. The trap is supplied with integrally flanged connections and can be maintained without disturbing the pipework. Vertical flanged connections, designated FT44V, are available for all sizes. Flow direction for the horizontal trap is clearly illustrated above. For vertically orientated traps the flow is downwards only.

Available options:

FT44 – Horizontal flow

FT44V – Vertical flow

Capsule

The BP99/32 capsule which is used in the FT44 is suitable for use on 150 °C superheat @ 0 bar g and 50 °C superheat @ 32 bar g.

Optional extras

A **manually adjustable needle valve** (designated 'C' on the nomenclature i.e. **FT44-C**) can be fitted to the **FT44 horizontal version only**.

This option provides a **steam lock release (SLR)** feature in addition to the standard air vent. For further information please consult Spirax Sarco.

The **top of the cover can be drilled and tapped 3/8" BSP or NPT** for the purpose of fitting a balance line if requested at the point of order.

The **bottom of the cover can be drilled and tapped 3/8" BSP or NPT** for the purpose of fitting a drain cock if requested at the point of order.

FT44

DN15, DN20 and DN25

DN15 shown

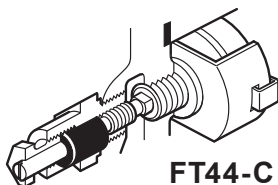
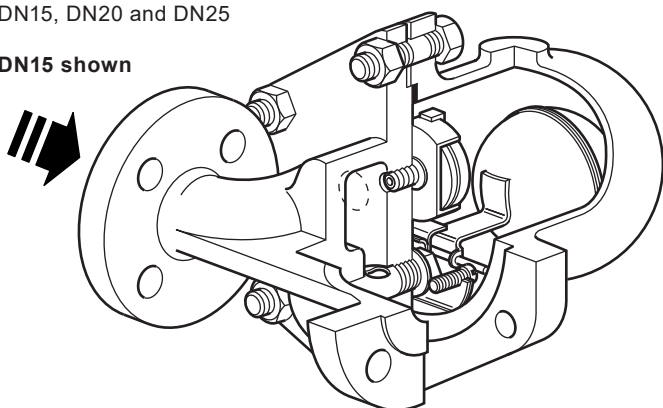

FT44

DN40 and DN50

DN50 shown

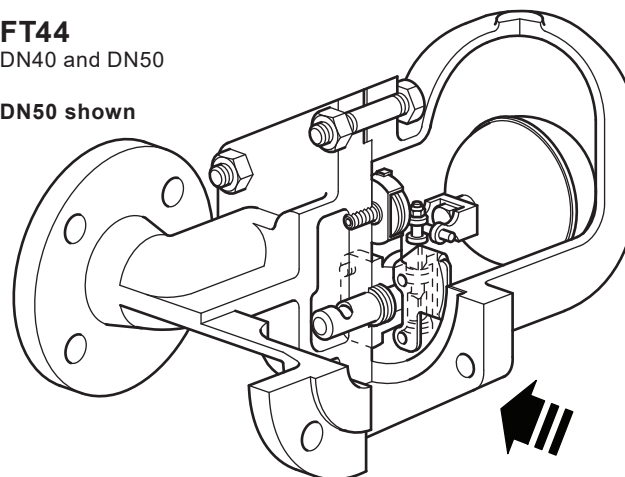

Standards

This product fully complies with the requirements of the European Pressure Equipment Directive 2014/68/EU and carries the  mark when so required.

Certification

This product is available with certification to EN 10204 3.1.

Note: All certification/inspection requirements must be stated at the time of order placement.

Sizes and pipe connections

DN15, DN20, DN25, DN40 and DN50.



Horizontal traps: Note the flow direction when facing the body: - DN15 to DN25 is left to right. - DN40 and DN50 is right to left. Standard flanges are EN 1092 PN40 with face-to-face dimensions in accordance with EN 26554 (Series 1), ASME B 16.5 Class 150, ASME B 16.5 Class 300 and JIS/KS 20 flanges are also available with extended face-to-face dimensions.

Vertical traps: Note that the flow direction is vertically downwards only.

Standard flanges are EN 1092 PN40 with face-to-face dimensions in accordance with EN 26554 (Series 1). ASME B 16.5 Class 150, ASME B 16.5 Class 300 and JIS/KS 20 are also available with face-to-face dimensions in accordance with EN 26554 (Series 1). ASME /JIS/KS flanges are supplied with tapped holes to receive flange bolts. ASME flanges have UNC threads and JIS/KS have metric threads.

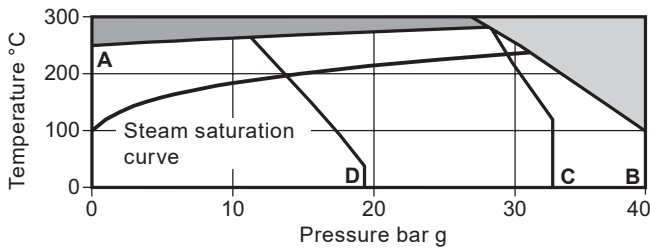
Pressure/temperature limits



-  The product **must not** be used in this region.
-  This product should not be used in this region as damage to the internals may occur.

A - B Flanged EN 1092 PN40 and ASME 300

A - C Flanged JIS/KS 2

A - D Flanged ASME 150.

Body design conditions	PN40
PMA Maximum allowable pressure	40 bar g @ 100 °C
TMA Maximum allowable temperature	300 °C @ 27.5 bar g
Minimum allowable temperature	-10 °C
PMO Maximum operating pressure for saturated steam service Note: The DN40 and DN50 traps are limited to a PMO equal to DPMX	32 bar g @ 239 °C
TMO Maximum operating temperature	285 °C @ 28.5 bar g
Minimum operating temperature Note: For lower operating temperatures consult Spirax Sarco	0 °C

	Size	DN15, DN20, DN25	DN40, DN50
ΔPMX Maximum differential pressure	FT44-4.5	4.5 bar	4.5 bar
	FT44-10	10 bar	10 bar
	FT44-14	14 bar	-
	FT44-21	21 bar	21 bar
	FT44-32	32 bar	32 bar

Product is safe for use under full vacuum conditions

Designed for a maximum cold hydraulic test pressure: 60 bar g

Caution: The trap in its complete operational form must not be subjected to a pressure greater than 48 bar otherwise damage to the internal mechanism may result.

Materials

FT44

DN15, DN20 and DN25

DN15 shown

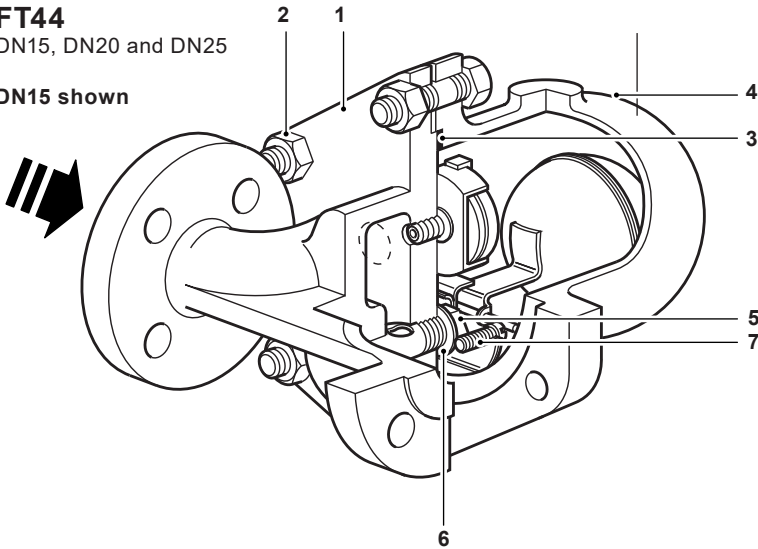

FT44
DN40 and DN50

DN50 shown

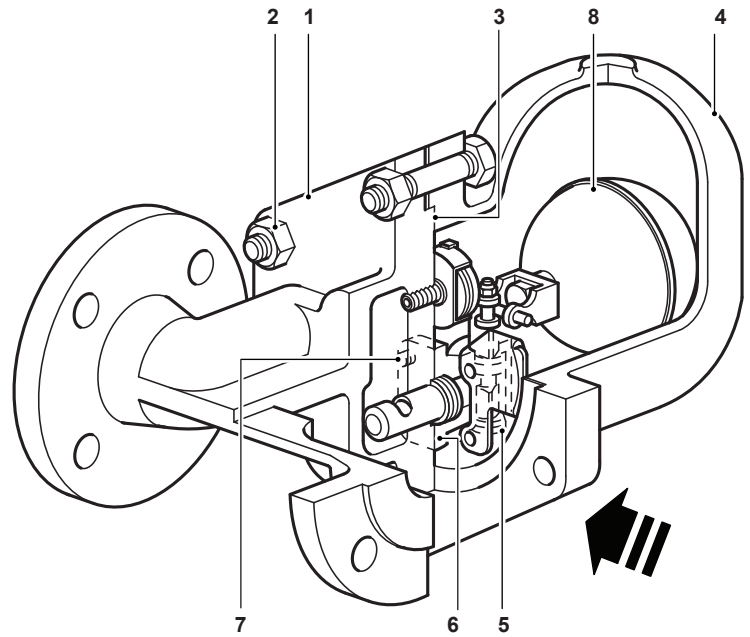

No.	Part	Material		
1	Body	Carbon steel	1.0619+N/WCB	
	Cover studs	Steel	BS 4882 B7M	
2	Cover nuts	DN15, DN20 and DN25	Steel EN 10269 25 Cr Mo 4	
		DN40 and DN50	Steel BS 3692 Gr. 8	
3	Cover gasket	Reinforced exfoliated graphite		
4	Cover	Carbon steel	1.0619+N/WCB	
	Valve seat	DN15, DN20 and DN25	Stainless steel BS 970 431 S29	
5	Main valve assembly with erosion deflector	DN40 and DN50	Stainless steel BS 3146 Pt2 ANC2	
			BS 970 416 S37	
	Valve seat gasket	DN15, DN20 and DN25	Stainless steel BS 1449 304 S11	
6	Main valve assembly gasket	DN40 and DN50	Reinforced exfoliated graphite	
	Pivot frame assembly screws	DN15, DN20 and DN25	Stainless steel BS 4183 18/8	
7	Main valve assembly	Bolts	DN40	Stainless steel BS 970 302 S25
		Studs and nuts	DN50	Stainless steel BS 970 431 S29

Materials continued on the next page

Materials (continued)

FT44

DN15, DN20 and DN25

DN15 shown

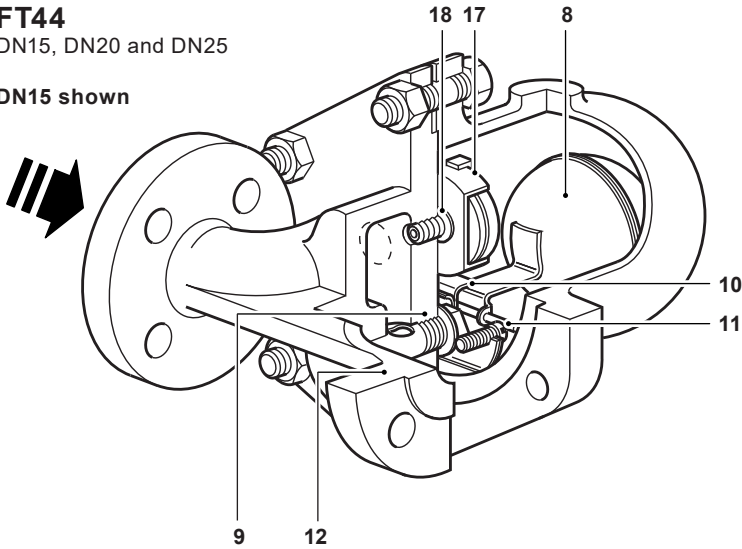

FT44-C

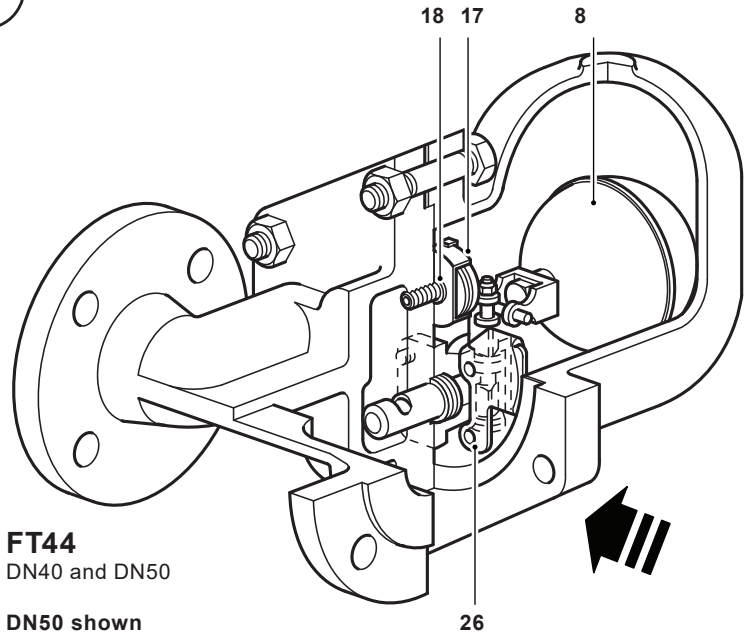
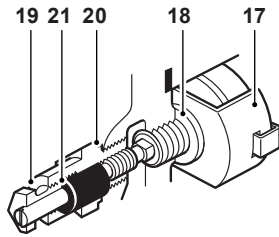

FT44
DN40 and DN50
DN50 shown

No.	Part		Material	
8	Ball float and lever		Stainless steel	BS 1449 304 S16
9	Support frame	DN15, DN20 and DN25	Stainless steel	BS 1449 304 S16
10	Pivot frame	DN15, DN20 and DN25	Stainless steel	BS 1449 304 S16
11	Pivot pin	DN15, DN20 and DN25	Stainless steel	
12	Erosion deflector		Stainless steel	BS 970 431 S29
17	Air vent assembly		Stainless steel	
18	Air vent seat gasket		Stainless steel	BS 1449 409 S19
19	SLR assembly		Stainless steel	BS 970 303 S31
20	SLR gasket		Steel	BS 1449 CS4
21	SLR seal		Graphite	
26	Inlet plate	DN40 and DN50 only	Stainless steel	BS 1449 304 S16

Capacities

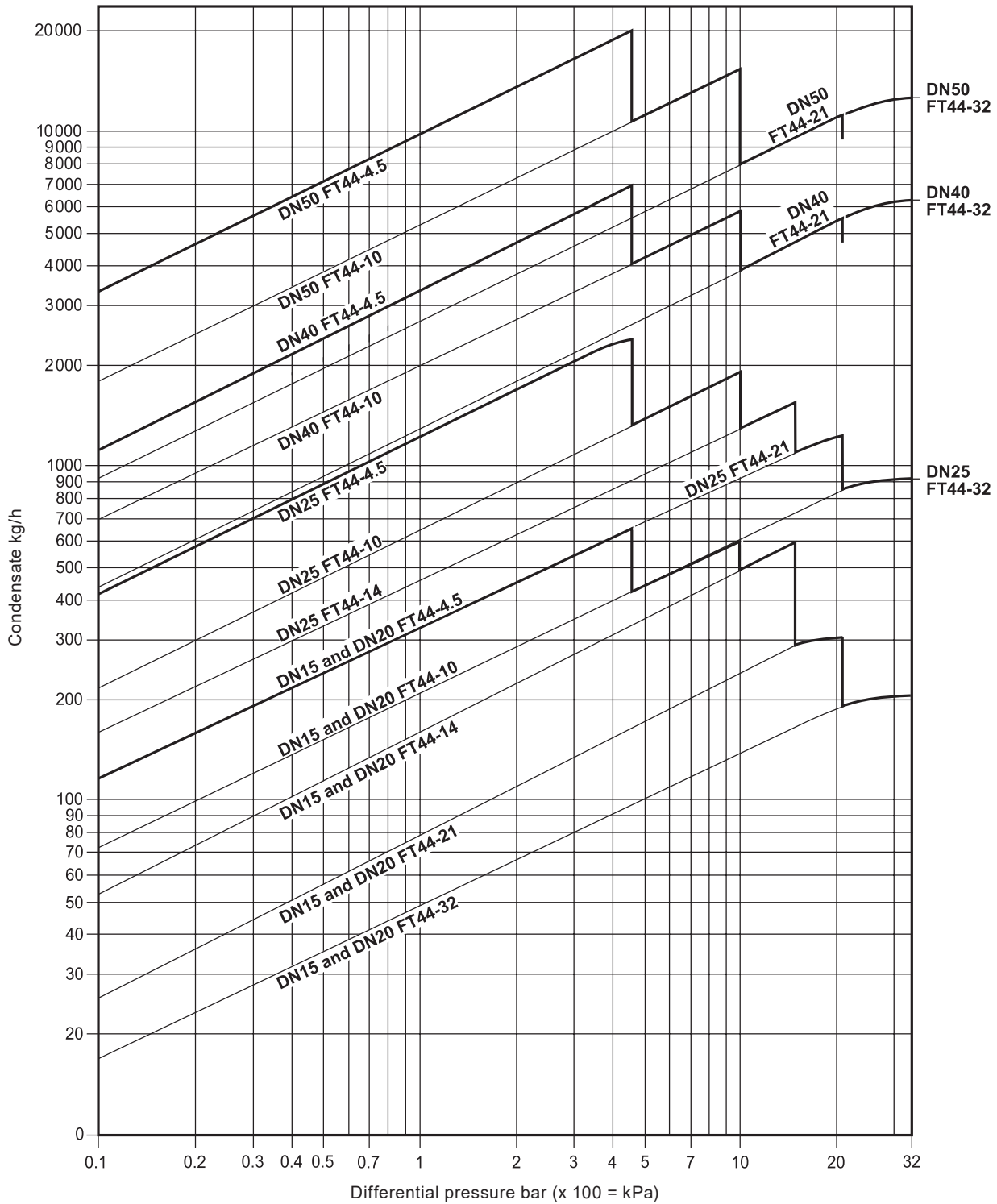

Additional cold water capacities from the thermostatic air vent under start-up conditions

Capacities shown above are based on condensate at saturation temperature. Under start-up conditions when the condensate is cold the internal thermostatic air vent will be open and provides additional capacity to the main valve.

The table opposite gives the minimum additional cold water capacities from the air vent.

ΔP (bar)		0.5	1	2	3	4.5	7	10	14	21	32
		Minimum additional cold water capacity (kg/h)									
DN15 and DN20	up to 21 bar	450	600	780	1 040	1 140	1 350	1 530	1 750	2 300	-
	32 bar only	170	250	380	520	600	780	860	1 140	1 170	1 200
DN25, DN40 and DN50	up to 21 bar	460	680	900	1 080	1 300	1 600	1 980	2 050	2 600	-
	32 bar only	90	120	350	460	600	850	900	1 020	1 200	1 300

Dimensions/weights (approximate) in mm and kg

Notes:

- Dimensions in brackets relate to vertical connections only.
- PN40 face-to-face dimensions are in accordance with EN 26554 (Series 1).

Size	PN40 A (A)	ASME 300 A (A)	ASME 150 A (A)	JIS/KS 20K A (A)	B	C
DN15	150 (150)	209 (150)	203 (150)	206 (150)	80	80
DN20	150 (150)	209 (150)	205 (150)	210 (150)	80	80
DN25	160 (160)	212 (160)	208 (160)	210 (160)	115	85
DN40	230 (230)	327 (230)	321 (230)	322 (230)	130	115
DN50	230 (230)	320 (230)	313 (230)	311 (230)	141	123

FT44

DN15 and DN20

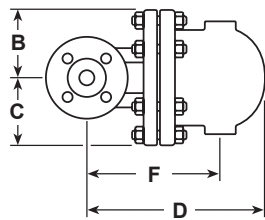
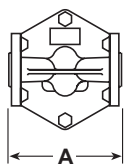

FT44

DN25, DN40 and DN50

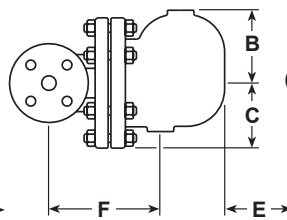

FT44V

DN15 and DN20

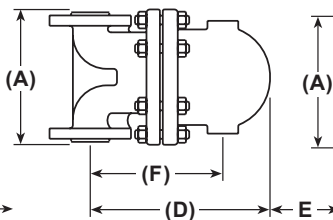

FT44V

DN25, DN40 and DN50

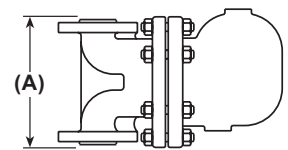

Size	PN40	ASM 300	ASME 150	JIS/KS 20K	All	PN40					ASME/ JIS/KS	All	Weight		
	A	A	A	A	(A)	B	C	D	D	(D)	E	F		F	(F)
DN15	150	209	203	206	(150)	80	80	215	163	(215)	120	155	103	(155)	10.8
DN20	150	209	205	210	(150)	80	80	225	163	(225)	120	165	103	(165)	10.8
DN25	160	212	208	210	(160)	115	85	276	209	(280)	170	215	147	(218)	15.0
DN40	230	327	321	322	(230)	130	115	326	248	(337)	200	200	121	(210)	33.0
DN50	230	320	313	311	(230)	141	123	332	251	(347)	200	235	154	(250)	34.0

Safety information, installation and maintenance

For full details see the Installation and Maintenance Instructions (IM-S02-30) supplied with the product.

Installation note:

The FT44 must be installed with the direction of flow as indicated on the body, and with the float arm in a horizontal plane so that it rises and falls vertically.

Disposal

This product is recyclable. No ecological hazard is anticipated with the disposal of this product, providing due care is taken.

How to order

Example: 1 off Spirax Sarco DN25 FT44-14 ball float steam trap, flanged to EN 1092 PN40 with carbon steel body and cover and thermostatic air vent.

Spare parts

The spare parts available are shown in solid outline. Parts drawn in a grey line are not supplied as spares.

Available spares

Main valve assembly with float (DN15, DN20 and DN25 horizontal traps)*	5, 6, 7, 8, 9, 10, 11
Main valve assembly with integral erosion deflector (DN40 and 50) ** (specify horizontal or vertical trap)	5, 6, 7, 12, 26
Main valve assembly with float and erosion deflector (DN15 and DN20 vertical traps only)	5, 6, 7, 8
Ball float (DN40 and DN50)	8
Air vent assembly	17, 18
Manually adjustable needle valve (SLR - Steam lock assembly) and air vent assembly (FT44-C)	17, 18, 19, 20, 21
Complete set of gaskets (packet of 3 sets)	3, 6, 18, 20

* On horizontal traps the erosion deflector on the DN15, DN20 and DN25 is pressed into the body during manufacture and not available as a spare.

** There is no erosion deflector on vertical traps.

How to order spares



Always order spares by using the description given in the column headed 'Available spares' and state the size and type of trap, including pressure range and orientation i.e.: horizontal or vertical connections.

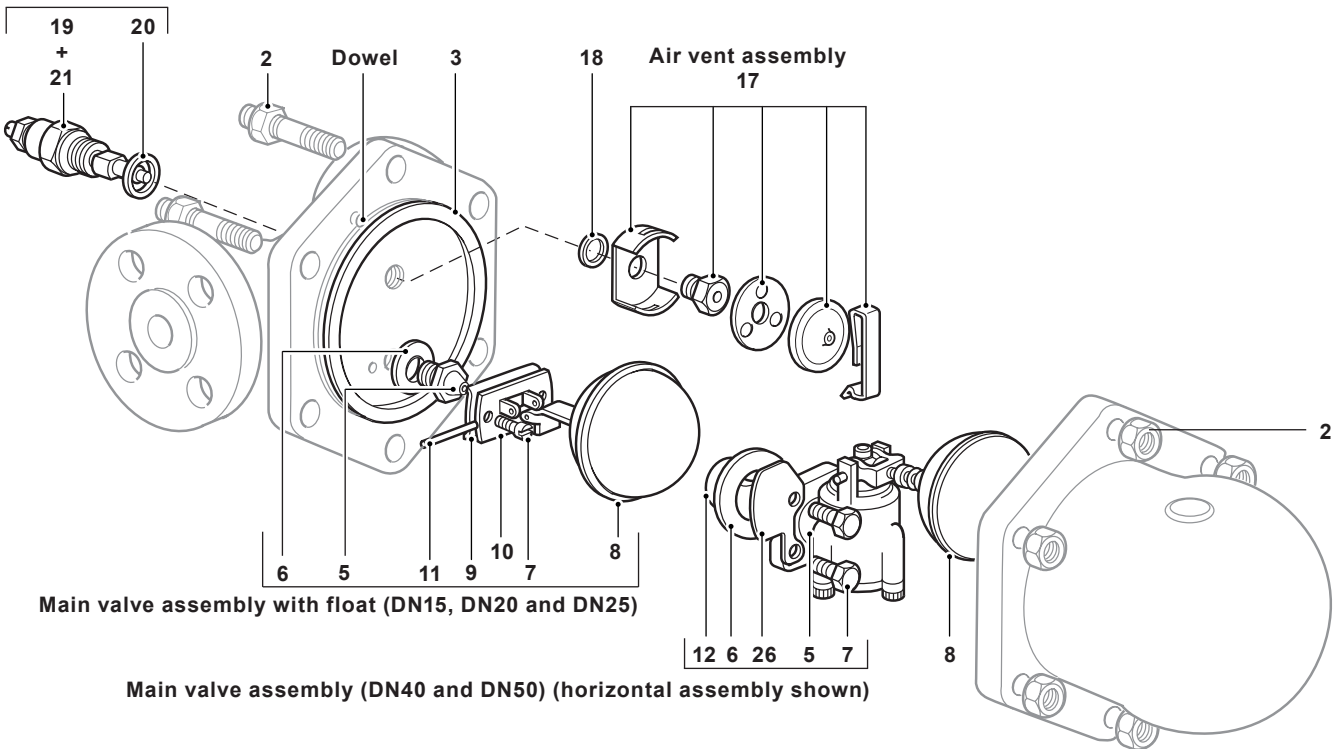

Example: 1 - Main valve assembly for a Spirax Sarco DN40 FT44-4.5V ball float steam trap, with vertical connections.

Manually adjustable needle valve



Recommended tightening torques

Item	Size	 or mm		N m
2	DN15, DN20 and DN25	17 A/F	M10 x 60	19 - 22
	DN40	24 A/F	M16 x 85	60 - 66
	DN50	24 A/F	M16 x 85	80 - 88
5	DN15, DN20 and DN25	17 A/F		50 - 55

Item	Size	 or mm		N m
7	DN15, DN20 and DN25		M5 x 20	2.5 - 2.8
	DN40	10 A/F	M6 x 20	10 - 12
	DN50	13 A/F	M8 x 20	20 - 24
17		17 A/F		50 - 55
19		22 A/F		50 - 55