



TI-P161-01
 ST Issue 2

Fig B36 Stainless Steel 'T' Type or Basket Type Strainers

Description

The **Fig B36 basket type** strainer has been designed for fitting into a horizontal pipeline and has a drain plug fitted at the bottom of the body to drain the unit. The **Fig B36 'T' type** strainer has been designed for fitting into a vertical pipeline and can have an optional drain plug fitted on the side of the body to drain the unit. These strainers are supplied as integrally flanged units and have a stainless steel strainer screen with 3 mm perforations as standard and the cover has a tapping for fitting a handling eyebolt:

- DN125 to DN150 3/8" UNC-2B tapping.
- DN200 to DN350 1/2" UNC-2B tapping.

Optional strainer screens - Available on request for all sizes:

- Stainless steel strainer screen having 0.8 mm perforations.
- Stainless steel strainer screen having 1.6 mm perforations.
- Stainless steel strainer screen having Mesh 40.
- Stainless steel strainer screen having Mesh 100.

Standards

This product fully complies with the requirements of the European Pressure Equipment Directive 97 / 23 / EC and carries the CE mark when so required.

Certification:

This product is available with certification to EN 10204 3.1 and NACE approval. **Note:** All certification/inspection requirements must be stated at the time of order placement.

Optional extras - Available at extra cost

Pressure gauge connections - Bosses are provided on the body upstream and downstream of the screen which can be drilled and tapped to accommodate pressure gauges.

The cover can be drilled and tapped for an air vent - If you want to use the strainer on a vertical pipeline ('T' position) the body should be drain of condensate via a drain plug that is situated at the side of the body.

Sizes and pipe connections

DN40, DN50, DN65, DN80, DN100, DN125, DN150, DN200, DN250, DN300 and DN350.

Flanged:

- EN 1092 PN16, PN25 and PN40.
- JIS / KS 10K and JIS / KS 20K.
- ASME B 16.5 Class 150 and Class 300.

Face-to-face dimensions are in accordance with:

- EN 558 Series 1 for the PN and JIS / KS.
- ASME B16.10 Class 150 for the ASME Class 150 rated design.
- ASME B16.10 Class 300 for the ASME Class 300 rated design.

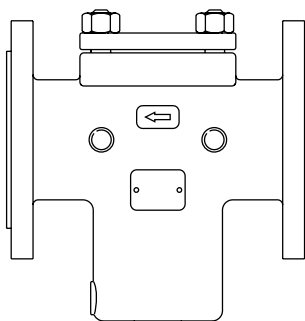
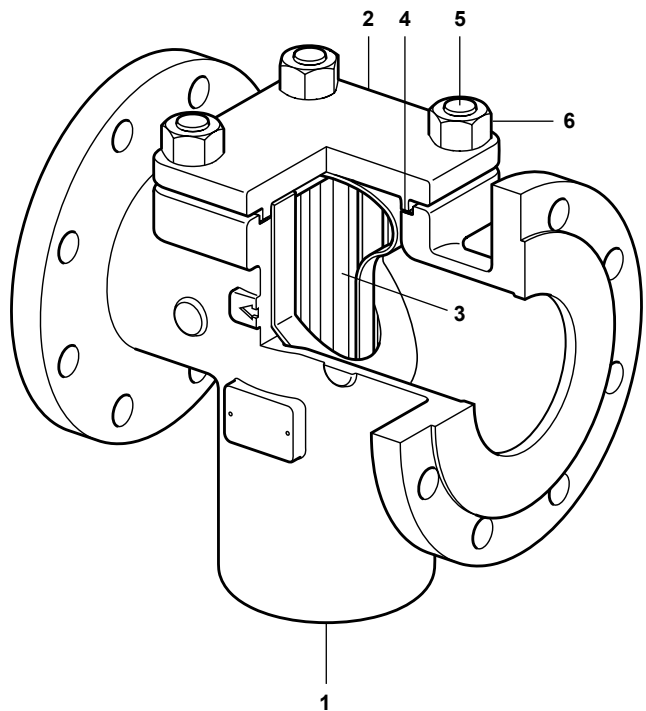

Basket type
 Designed for fitting into a horizontal pipeline

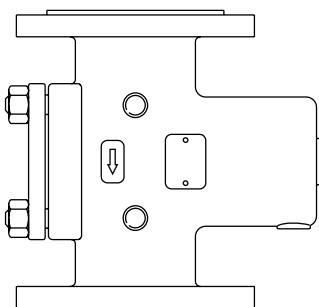

'T' type
 Designed for fitting into a vertical pipeline

Materials

No.	Part	Material	
1	Body	Stainless steel	EN 10213 1.4308 and ASTM A 351-CF8
2	Cover	Stainless steel	EN 10213 1.4308 and ASTM A 351-CF8
3	Screen	Stainless steel	
4	Gasket	Reinforced exfoliated graphite	
5	Studs	Carbon steel	ASTM A193 Gr. B8M2
6	Nuts	Carbon steel	ASTM A194 Gr. 8M

Pressure / temperature limits - EN 1092

Flanged:
PN16
PN25
PN40

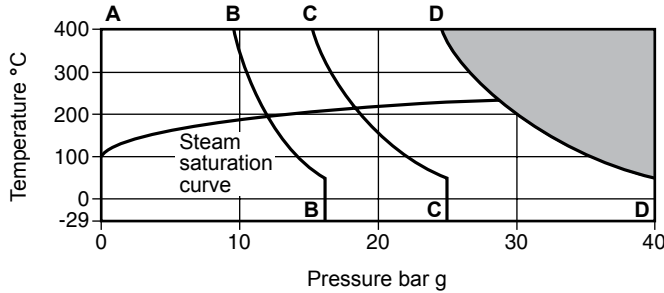

The product **must not** be used in this region or beyond the parameter of the PMA or TMA of the relative end connection.

A - B - B	PN16	Body design condition	PN16
		PMA Maximum allowable pressure	16 bar g @ 50°C
		TMA Maximum allowable temperature	400°C @ 9.5 bar g
		Minimum allowable temperature	-29°C
		PMO Maximum operating pressure for saturated steam service	12.1 bar g @ 192°C
		TMO Maximum operating temperature	400°C @ 9.5 bar g
		Minimum operating temperature	-29°C
		Designed for a maximum cold hydraulic test pressure of:	24 bar g
A - C - C	PN25	Body design condition	PN25
		PMA Maximum allowable pressure	25 bar g @ 50°C
		TMA Maximum allowable temperature	400°C @ 15.1 bar g
		Minimum allowable temperature	-29°C
		PMO Maximum operating pressure for saturated steam service	18.4 bar g @ 209°C
		TMO Maximum operating temperature	400°C @ 15.1 bar g
		Minimum operating temperature	-29°C
		Designed for a maximum cold hydraulic test pressure of:	37.5 bar g
A - D - D	PN40	Body design condition	PN40
		PMA Maximum allowable pressure	40 bar g @ 50°C
		TMA Maximum allowable temperature	400°C @ 24.1 bar g
		Minimum allowable temperature	-29°C
		PMO Maximum operating pressure for saturated steam service	28.7 bar g @ 232°C
		TMO Maximum operating temperature	400°C @ 24.1 bar g
		Minimum operating temperature	-29°C
		Designed for a maximum cold hydraulic test pressure of:	60 bar g

Pressure / temperature limits - ASME

**Flanged:
ASME Class 150
ASME Class 300**

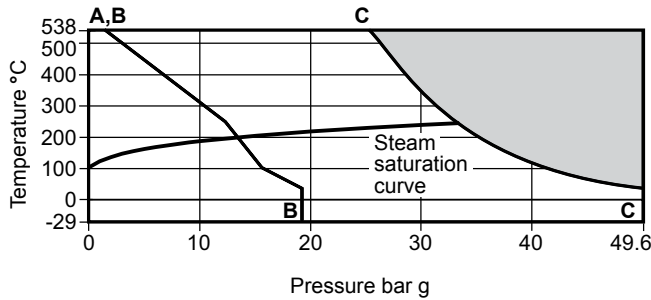

The product **must not** be used in this region or beyond the parameter of the PMA or TMA of the relative end connection.

A - B - B ASME 150	Body design condition	ASME Class 150
	PMA Maximum allowable pressure	19 bar g @ 38°C
	TMA Maximum allowable temperature	538°C @ 1.4 bar g
	Minimum allowable temperature	-29°C
	PMO Maximum operating pressure for saturated steam service	13.3 bar g @ 195°C
	TMO Maximum operating temperature	538°C @ 1.4 bar g
	Minimum operating temperature	-29°C
	Designed for a maximum cold hydraulic test pressure of:	28.5 bar g
A - C - C ASME 300	Body design condition	ASME Class 300
	PMA Maximum allowable pressure	49.6 bar g @ 38°C
	TMA Maximum allowable temperature	538°C @ 24.4 bar g
	Minimum allowable temperature	-29°C
	PMO Maximum operating pressure for saturated steam service	33 bar g @ 241°C
	TMO Maximum operating temperature	538°C @ 24.4 bar g
	Minimum operating temperature	-29°C
	Designed for a maximum cold hydraulic test pressure of:	74.4 bar g

Pressure / temperature limits - JIS/KS

Flanged:
JIS / KS 10K
JIS / KS 20K

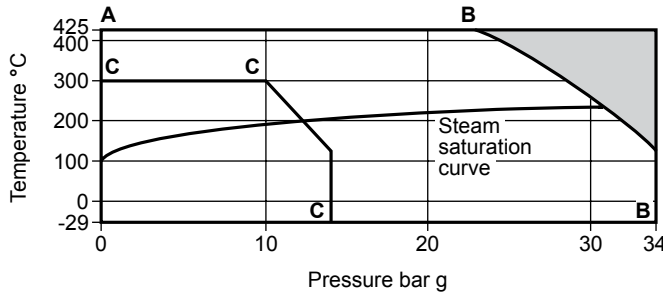

The product **must not** be used in this region or beyond the parameter of the PMA or TMA of the relative end connection.

A - B - B	JIS / KS 20K	Body design condition	JIS / KS 20K
		PMA Maximum allowable pressure	34 bar g @ 120°C
		TMA Maximum allowable temperature	425°C @ 20 bar g
		Minimum allowable temperature	-29°C
		PMO Maximum operating pressure for saturated steam service	30.5 bar g @ 240°C
		TMO Maximum operating temperature	425°C @ 20 bar g
		Minimum operating temperature	-29°C
		Designed for a maximum cold hydraulic test pressure of:	51 bar g
C - C - C	JIS / KS 10K	Body design condition	JIS / KS 10K
		PMA Maximum allowable pressure	14 bar g @ 120°C
		TMA Maximum allowable temperature	300°C @ 10 bar g
		Minimum allowable temperature	-29°C
		PMO Maximum operating pressure for saturated steam service	12.5 bar g @ 193°C
		TMO Maximum operating temperature	300°C @ 10 bar g
		Minimum operating temperature	-29°C
		Designed for a maximum cold hydraulic test pressure of:	21 bar g

Typical product name-plate

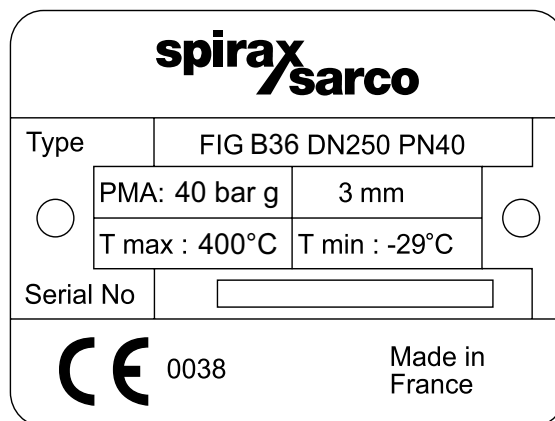

K_v values

Size	DN40	DN50	DN65	DN80	DN100	DN125	DN150	DN200	DN250	DN300	DN350
K _v	25	43	84	156	353	488	748	1869	3686	5244	8100

For conversion: C_v (UK) = K_v x 0.963 C_v (US) = K_v x 1.156

Dimensions / Weights (approximate) in mm and kg

Body rating	Size	Dimensions						Tappings				Weights	
		PN JIS KS	A		B	C	D	Standard Bottom drain	Lateral 'T' type drain	Optional		PN JIS KS	ASME
			150	300						Pressure gauge	Air vent on the cover		
PN40	DN40	200	165	229	121.5	71.5	150	1/2"	3/8"	1/4"	1/4"	14.0	15.0
	DN50	230	203	267	131.5	79.0	170	1/2"	3/8"	1/4"	1/4"	16.0	16.5
PN25	DN65	290	216	292	152.0	97.5	190	3/4"	1/2"	1/4"	1/4"	19.0	20.0
PN16	DN80	310	241	318	161.0	114.5	210	3/4"	1/2"	1/4"	1/4"	30.0	33.0
JIS/KS 20	DN100	350	292	356	181.0	125.5	250	3/4"	1/2"	1/4"	1/4"	35.5	42.5
JIS/KS 10	DN125	400	330	400	218.5	148.0	290	1 1/2"	3/4"	1/4"	1/4"	67.0	74.5
ASME 150 and ASME 300	DN150	480	356	444	238.5	174.5	330	1 1/2"	3/4"	1/4"	1/4"	76.0	86.5
	DN200	600	495	559	290.5	206.0	400	1 1/2"	3/4"	1/4"	1/4"	166.0	175.0
	DN250	730	622	622	325.5	244.0	480	1 1/2"	3/4"	1/4"	1/2"	205.0	210.5
	DN300	850	698	711	368.5	307.5	550	2"	1"	1/4"	1/2"	341.5	369.5
	DN350	980	787	838	383.5	332.0	600	2"	1"	1/4"	1/2"	459.5	426.5

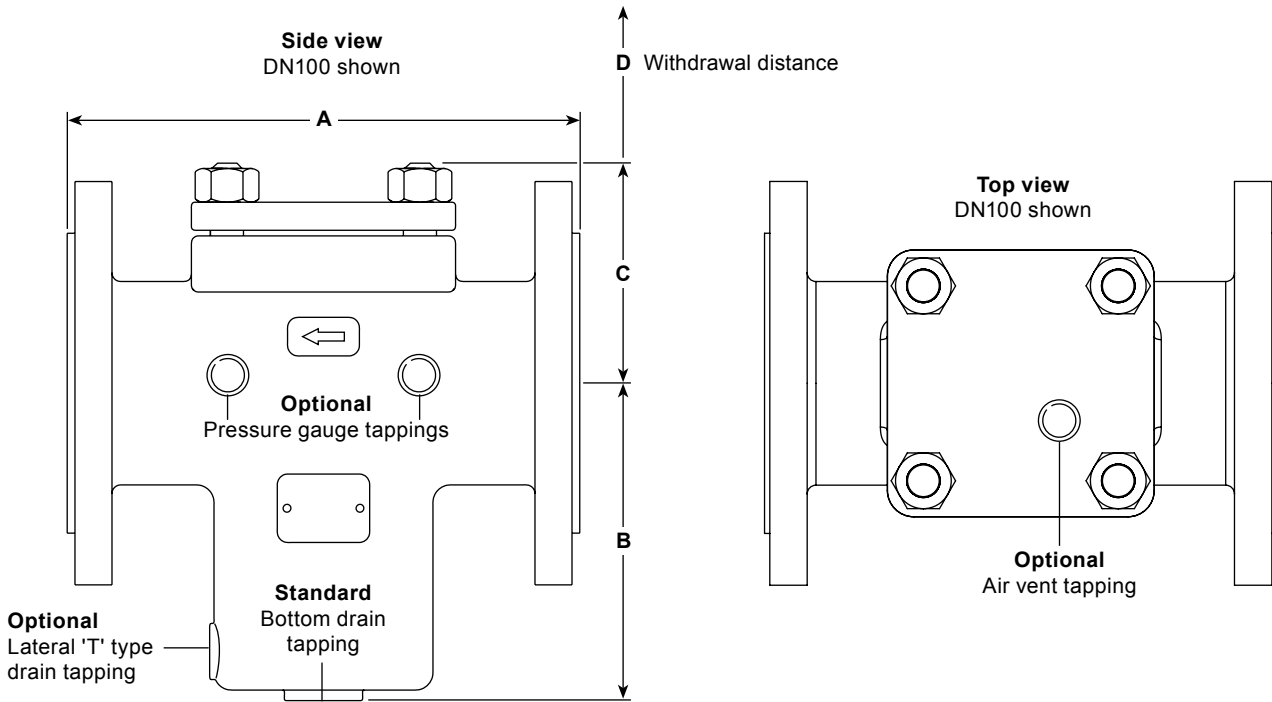

Body rating	Size	Screening area (cm ²)	Opening %				Opening / Inlet ratio			
			3.0	1.6	0.8	M100 M40	3.0	1.6	0.8	M100 M40
PN40	DN40	139	32%	30%	26%	23%	3.54	3.32	2.88	2.53
	DN50	216					3.52	3.30	2.86	2.51
PN25	DN65	343					3.31	3.10	2.69	2.36
PN16	DN80	590					3.76	3.52	3.05	2.68
JIS/KS 20	DN100	916					3.73	3.50	3.03	2.66
JIS/KS 10	DN125	1191					3.11	2.91	2.52	2.22
ASME 150 and ASME 300	DN150	1692					3.06	2.87	2.49	2.19
	DN200	3486					3.55	3.33	2.89	2.54
	DN250	5223					3.40	3.19	2.77	2.43
	DN300	7379					3.34	3.13	2.71	2.39
	DN350	9597	3.19	2.99	2.59	2.28				

Safety information, installation and maintenance

For full details see the Installation and Maintenance Instructions (IM-S60-24) supplied with the product.

Warning:

The strainer cover gasket contains a thin stainless steel support ring, which may cause physical injury if it is not handled and disposed of carefully.

Installation note:

The Fig B36 basket type strainer must be fitted in a horizontal pipeline and the Fig B36 'T' type strainer must be fitted in a vertical pipeline. Both must be fitted with the direction of flow as shown on the body.

Suitable isolation valves must be installed to allow for safe maintenance and strainer replacement.

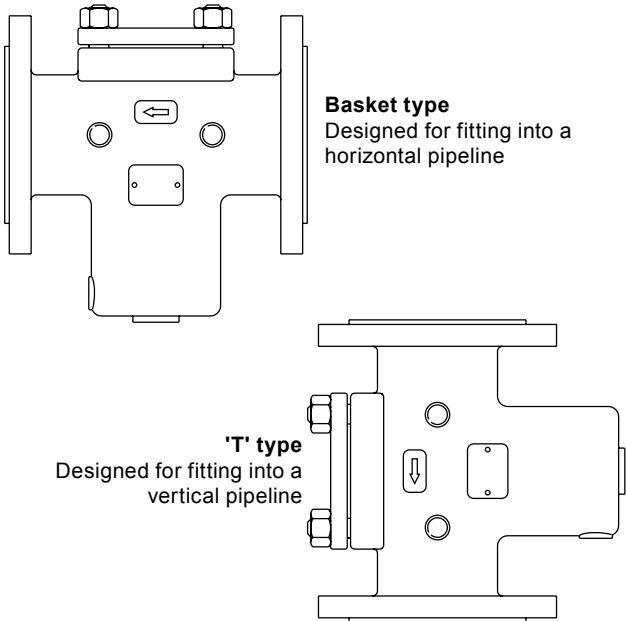

Maintenance note:

Maintenance can be completed with the strainer in the pipeline, once the safety procedures have been observed. It is recommended that a new gasket is used whenever maintenance is undertaken.

Recommended tightening torques

Size	Quantity	Dimensions	Torque (N m)
DN40	4	½" - 13 UNC	15
DN50			22
DN65	4	5/8" - 11 UNC	40
DN80	4	¾" - 10 UNC	70
DN100			100
DN125	6	¾" - 10 UNC	100
DN150	6		160
DN200	8	7/8" - 11 UNC	205
DN250	12		205
DN300	12	1 1/8" - 7 UNC	375
DN350	14		420

Disposal:

The product is recyclable. No ecological hazard is anticipated with disposal of this product, providing due care is taken.

How to order

Example: 1 off Spirax Sarco DN200 Fig B36 strainer flanged to EN 1092 PN16 with a stainless steel screen having 3 mm perforations.

Spare parts

The spare parts available are shown in solid outline. Parts drawn in broken line are not supplied as spares.

Available spares

Strainer screen (state material, size of perforations and size of strainer)	4
Cap gasket (packet of 3)	3
Set of cap studs and nuts	5, 6

How to order spares

Always order spares by using the description given in the column headed 'Available spares' and state the size and type of strainer.

Example: 1 - Stainless steel screen having 3 mm perforations for a DN250 Spirax Sarco Fig B36 strainer.

Note: When ordering a spare screen it is advisable to order a cap gasket (packet of 3).

