

spirax sarco

TI-P164-01
 ST Issue 6

Fig 4 Brass Strainer

Description

The Fig 4 is an angle type, brass bodied, screwed strainer. As standard it will be supplied with a stainless steel screen having 0.8 mm perforations. Optionally other perforations and mesh sizes are available as well as monel screens. The strainer cap can be drilled and tapped for blowdown and drain valves if required.

Standards

This product fully complies with the requirements of the European Pressure Equipment Directive 97/23/EC and carries the CE mark when so required.

Certification

This product is available with certification to EN 10204 2.2.
Note: All certification/inspection requirements must be stated at the time of order placement.

Sizes and pipe connections

1/2" and 3/4" screwed BSP (BS 21 parallel) or NPT.

Optional extras

Strainer screens

Stainless steel screen	Perforations	1.6 and 3 mm
	Mesh	40, 100 and 200
Monel screen	Perforations	0.8 and 3 mm
	Mesh	100

Blowdown or drain valve connections

The cap can be drilled and tapped to the following sizes to enable a blowdown or drain valve to be fitted at extra cost.

Strainer size	Blowdown valve or drain valve
1/2" and 3/4"	1/2"

Pressure/temperature limits (ISO 6552)

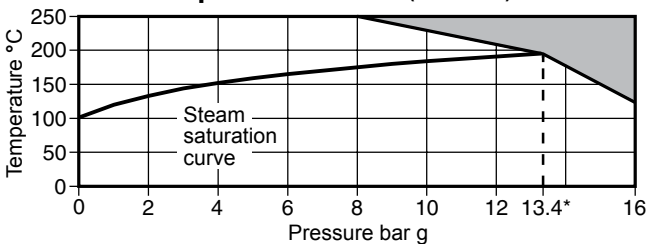

The product **must not** be used in this region.

Body design conditions		PN16
PMA	Maximum allowable pressure	16 bar g @ 120°C
TMA	Maximum allowable temperature	250°C @ 8 bar g
Minimum allowable temperature		0°C
* PMO	Maximum operating pressure for saturated steam service	13.4 bar g @ 196°C
TMO	Maximum operating temperature	250°C @ 8 bar g
Minimum operating temperature		0°C

Note: For lower operating temperatures consult Spirax Sarco
 Designed for a maximum cold hydraulic test pressure of 24 bar g

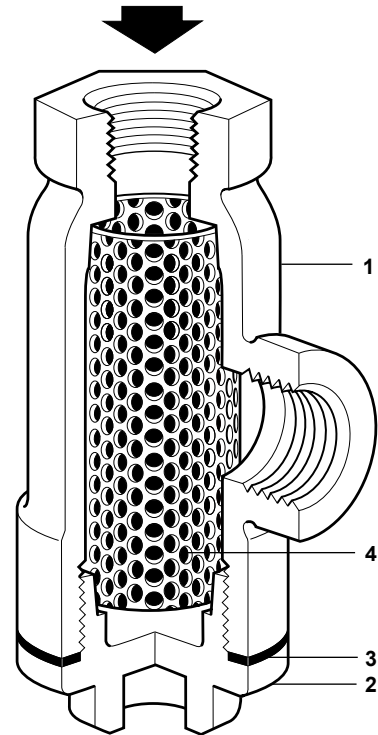

Materials

No.	Part	Material	
1	Body	Brass	EN 12165 CW 617N
2	Cap	Brass	EN 12165 CW 617N
3	Cap gasket	Reinforced exfoliated graphite	
4	Strainer screen	Stainless steel	316L

K_v values

Size	1/2"	3/4"
Perforations 0.8, 1.6 and 3 mm	4	4
Mesh 40 and 100	4	4
Mesh 200	4	4

For conversion: C_v (UK) = K_v x 0.963 C_v (US) = K_v x 1.156

Dimensions / weight (approximate) in mm and kg

Size	A	B	C	D	E	Screening area cm ²	Weight
1/2"	36	98	67	42	44	43	0.7
3/4"	36	98	67	42	44	43	0.7

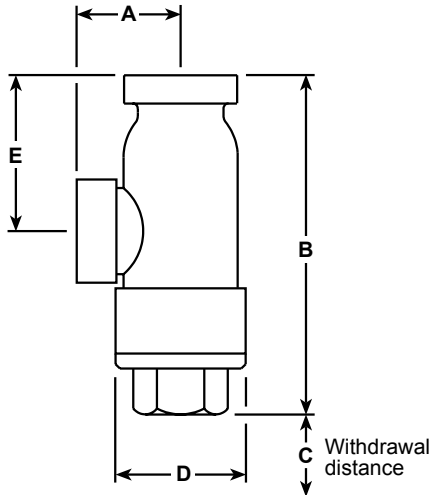

Safety information, installation and maintenance

For full details see the Installation and Maintenance Instructions (IM-P164-06) supplied with the product.

Warning:

The strainer cap gasket contains a thin stainless steel support ring, which may cause physical injury if not handled and disposed of carefully.

Installation note:

The strainer should be installed with the strainer cap at the bottom with the inlet at the top.

Maintenance note:

Maintenance can be completed with the strainer in the pipeline.

Disposal

The product is recyclable. No ecological hazard is anticipated with disposal of this product, providing due care is taken.

How to order

Example: 1 off Spirax Sarco 1/2" Fig 4 strainer, screwed BSP, with a stainless steel screen having 0.8 mm perforations.

Spare parts

The spare parts available are shown in solid outline. Parts drawn in broken line are not supplied as spares.

Available spares

Strainer screen	4
(state material, size of perforation or mesh and size of strainer)	
Cap gasket (3 off)	3



How to order spares

Always order spares by using the description given in the column headed 'Available spares' and state the size and type of strainer and perforation or mesh required.

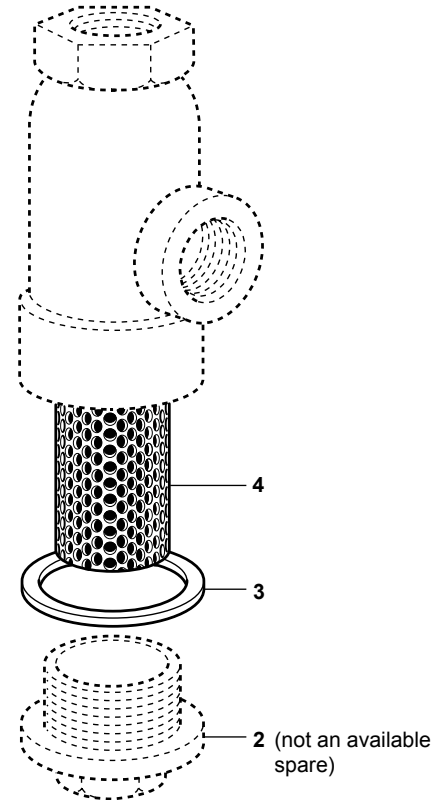
Example: 1 - Stainless steel strainer screen having 0.8 mm perforations for a 1/2" Spirax Sarco Fig 4 strainer.



Recommended tightening torques

Item	Size	 or  mm	N m
2	1/2" and 3/4"	26 A/F 1" BSP	42 - 48