



Fig 36HP Stainless Steel Strainer

Description

The Fig 36HP is a Stainless steel Y-type strainer that has been designed in accordance with ASME B16.34:2004 and ASME VIII, that is readily available with integrally flanged or butt weld connections. The standard stainless steel screen in the DN15 to DN80 size range has 0.8 mm perforations, and 1.6 mm perforations in the DN100 to DN200 size range - See 'Optional extras' for alternative perforations/mesh sizes and screen materials. If required, the strainer cover can be drilled and tapped for blowdown and drain valves.

Standards

This product fully complies with the requirements of the European Pressure Equipment Directive 2014/68/EU and carries the

 mark when so required.

Certification

This product is available with certification to EN 10204 3.1 and NACE Approval.

Note: All certification/inspection requirements must be stated at the time of order placement.

Sizes and pipe connections

Flanged:

EN 1092 PN100, EN 1092 PN63, ASME (ANSI) B16.5 Class 600 and ASME (ANSI) 600 RTJ - DN15, DN20, DN25, DN40, DN50, DN65, DN80, DN100, DN150 and DN200.

Screwed: BSP T Rp (ISO 7-1) or NPT - 1/2", 3/4", 1", 1 1/2" and 2"

Socket weld:

ASME (ANSI) B16.11 Class 3000 - 1/2", 3/4", 1", 1 1/2" and 2"

Butt weld:

ASME (ANSI) B16.25 Schedule 40 and Schedule 80 - 1/2", 3/4", 1", 1 1/2", 2", 2 1/2", 3", 4", 6" and 8"

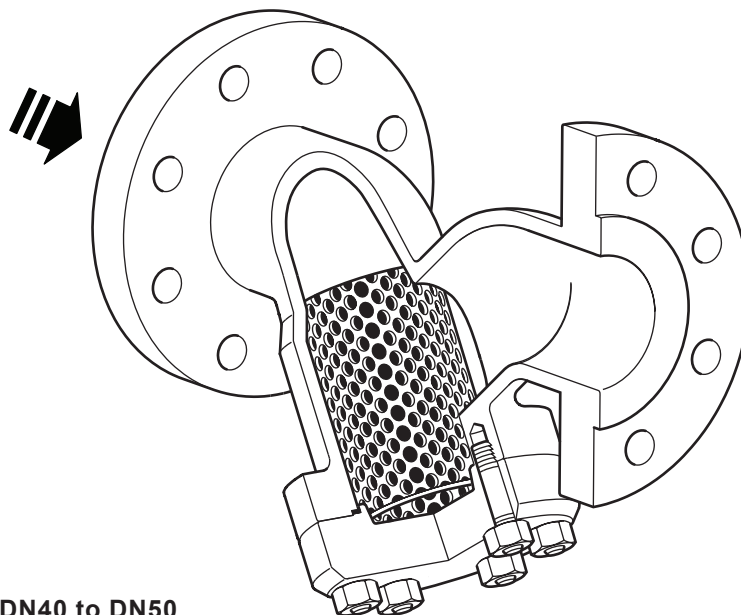

DN40 to DN50

Optional extras

The following optional extras are available for all unit sizes at an extra cost and must be stated at the time of order placement:

	0.8 mm (standard), 1 mm, 1.6 mm, 3 mm and 6 mm
Perforations:	Contact Spirax Sarco for availability of perforations not displayed.
	M20, M40, M60, M100, M200 and M400
Mesh:	Contact Spirax Sarco for availability of mesh screens not displayed.
Screen material:	AISI 316, AISI 316L (standard), AISI 304, AISI 304L and Monel

	Strainer size	Blowdown valve	Drain valve
Blowdown/drain valve connection The cover can be drilled to the following sizes to enable a blowdown or drain valve to be fitted. This option is available at extra cost.	DN15	1/4"	1/4"
	DN20 and DN25	1/2"	1/2"
	DN40	1"	3/4"
	DN50 to DN100	1 1/4"	3/4"
	DN150 to DN200	2"	3/4"

Materials

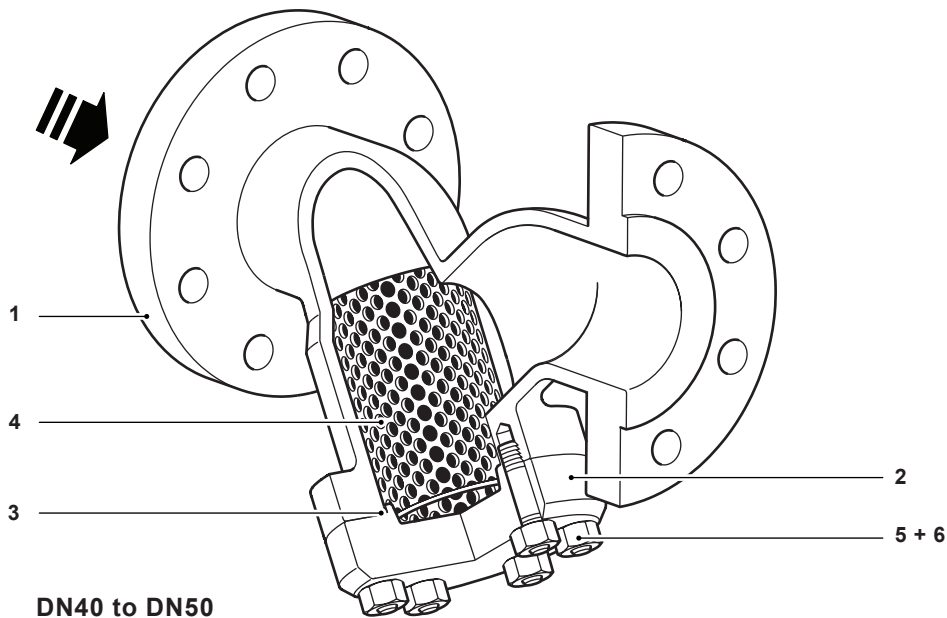

No.	Part	Material	
1	Body	Stainless steel	EN 10213 1.4408 and ASTM A351 CF8M
2	Cover	Stainless steel	EN 10213 1.4408 and ASTM A351 CF8M
3	Cover gasket	Stainless steel + Graphite	Spiral wound
4	Strainer screen	Stainless steel	AISI 316L
5	Cover stud	Stainless steel	ASTM A193 Gr. B8M2
6	Cover nut	Stainless steel	ASTM A194 Gr. 8M

Pressure/temperature limits

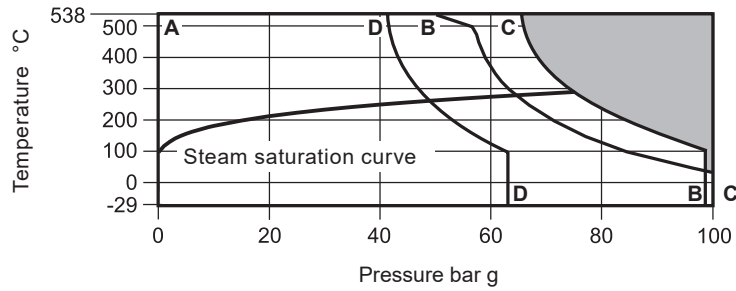

The product **must not** be used in this region.

A - B Flanged ASME (ANSI) B16.5 Class 600, ASME (ANSI) 600 RTJ, Screwed NPT, Socket weld ASME (ANSI) B16.11 Class 3000 and Butt weld ASME (ANSI) B16.25 Schedule 40 and 80.

A - C Flanged EN 1092 PN100 and Screwed BSP T Rp (ISO 7-1).

A - D Flanged EN 1092 PN63.

	A - B Flanged ASME 600 and 600 RTJ Screwed NPT Socket weld and Butt weld	A - C Flanged EN 1092 PN100 and Screwed BSP T Rp (ISO 7-1)	A - D Flanged EN 1092 PN63
Body design conditions	ASME 600	PN100	PN63
PMA Maximum allowable pressure	99.3 bar g @ 38 °C	100 bar g @ 50 °C	63 bar g @ 50 °C
TMA Maximum allowable temperature	538 °C @ 50 bar g	538 °C @ 65.4 bar g	538 °C @ 41.2 bar g
Minimum allowable temperature	-29 °C	-29 °C	-29 °C
PMO Maximum operating pressure	99.3 bar g @ 38 °C	100 bar g @ 50 °C	63 bar g @ 50 °C
TMO Maximum operating temperature	538 °C @ 50 bar g	538 °C @ 65.4 bar g	538 °C @ 41.2 bar g
Minimum operating temperature	-29 °C	-29 °C	-29 °C
Note: For lower operating temperatures consult Spirax Sarco.			
Product is safe for use under full vacuum conditions			
Designed for a maximum cold hydraulic test pressure of:	153 bar g	150 bar g	95 bar g

Kv values

Size	DN15	DN20	DN25	DN40	DN50	DN65	DN80	DN100	DN150	DN200
Perforations 0.8, 1.6 and 3 mm	5	8	13	29	46	72	103	155	340	588
Mesh M40 and M100	5	8	13	29	46	72	103	155	340	588
Mesh M200	4	6	10	23	37	58	83	124	268	464

Please consult Spirax Sarco for the Kv values of the following screens: 1 mm, 6 mm, M20, M60 and M400.

For conversion:

C_v (UK) = $K_v \times 0.963$

C_v (US) = $K_v \times 1.156$

Dimensions/weights (approximate) in mm and kg

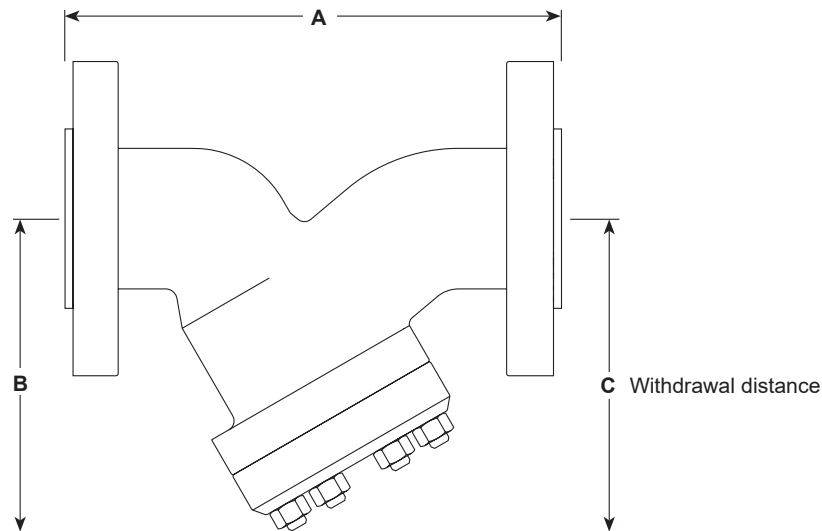

Size	A			B	C	Weights		
	ASME 600	PN100	Screwed Socket weld Butt weld			ASME 600	PN100	Screwed Socket weld Butt weld
DN15	165	210	165	117	200	3.6	4.0	1.6
DN20	190	230	190	117	200	4.6	4.9	1.8
DN25	216	230	216	117	200	5.6	7.6	2.2
DN40	241	260	241	195	330	12.2	12.2	7.2
DN50	292	300	292	195	330	17.4	18.0	7.6
DN65	330	340	330	222	340	34.0	35.0	16.2
DN80	356	380	356	222	340	35.0	36.0	20.6
DN100	432	430	432	280	458	60.0	59.0	31.9
DN150	559	550	559	360	610	130.0	128.0	74.8
DN200	660	650	660	455	775	222.0	222.0	143.5

Safety information, installation and maintenance

For full details see the Installation and Maintenance Instructions (IM-S60-18) supplied with the product.

Installation note:

The strainer should be installed in the direction of flow, as indicated on the body. On applications involving steam or gases the pocket should be in horizontal plane. On liquid systems the pocket should point downwards.

Warning:

The strainer cover gasket contains a thin stainless steel support ring, which may cause physical injury if not handled and disposed of carefully.

Disposal

This product is recyclable. No ecological hazard is anticipated with the disposal of this product, provided due care is taken.

How to order

Example: 1 off Spirax Sarco DN40 Fig 36HP strainer having the standard stainless steel screen with 0.8 mm perforations and flanged EN 1092 PN100 connections.

Spare parts

The spare parts available are shown in solid outline. Parts drawn in a grey line are not supplied as spares.

Available spares

Cover gasket (packet of 3)	3
Strainer screen + Cover gasket	Strainer screen 4
	Cover gasket 3



How to order spares

Always order spares by using the description given in the column headed 'Available spares' and state the size and type of strainer and perforation or mesh required.

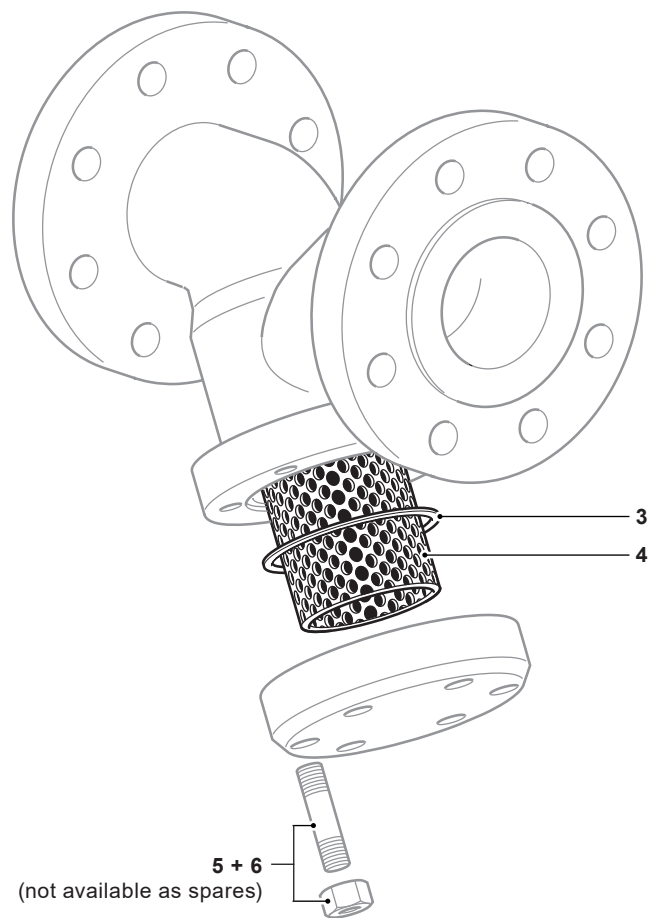
Example: 1 - Strainer screen + Cover gasket. The strainer screen is to be stainless steel having 0.8 mm perforations for a DN50 Spirax Sarco Fig 36HP strainer having EN 1092 PN63 flanged connections.



Recommended tightening torques - Items 5 and 6

Sizes	Qty	or		N m
				
DN15 - DN25	4	7/16"	1/2" - 13 UNC	20 - 30
DN40 - DN50	8	7/16"	1/2" - 13 UNC	30 - 40
DN65 - DN80	8	1 1/16"	5/8" - 11 UNC	50 - 60
DN100	8	1 1/4"	3/4" - 10 UNC	80 - 90
DN150	8	1 7/16"	7/8" - 9 UNC	100 - 110
DN200	12	1 13/16"	1 1/4" - 7 UNC	180 - 190