



Fig 3616 Austenitic Stainless Steel Strainer - ASTM Material

Description

The Fig 3616 is an austenitic stainless steel integrally flanged Y-type strainer with flanged screen cover in ASTM material. The standard stainless steel screen in the ½" to 3" has 0.8 mm perforations and in the 4" to 8" it has 1.6 mm perforations. As options, other perforation and mesh sizes are available as well as monel screens. The strainer cap can be drilled and tapped for blowdown and drain valves if required. The body can also be drilled and tapped for pressure tapplings if required.

Standards

This product fully complies with the requirements of the European Pressure Equipment Directive 2014/68/EU and carries the mark when so required.

Certification

This product is available with certification to EN 10204 3.1.

Note: All certification/inspection requirements must be stated at the time of order placement.

Sizes and pipe connections

½", ¾", 1", 1¼", 1½", 2", 2½", 3", 4", 5", 6" and 8"
 Standard flange ASME (ANSI) Class 150.

Optional extras

Strainer screens

Stainless steel screen	Perforations	1.6 mm	(½" to 3")
		3.0 mm	(½" to 8")
	Mesh	40, 100, 200	
Monel screen	Perforations	0.8 mm	(½" to 3")
		1.6 mm	(4" to 8")
		3.0 mm	(½" to 8")
	Mesh	100	

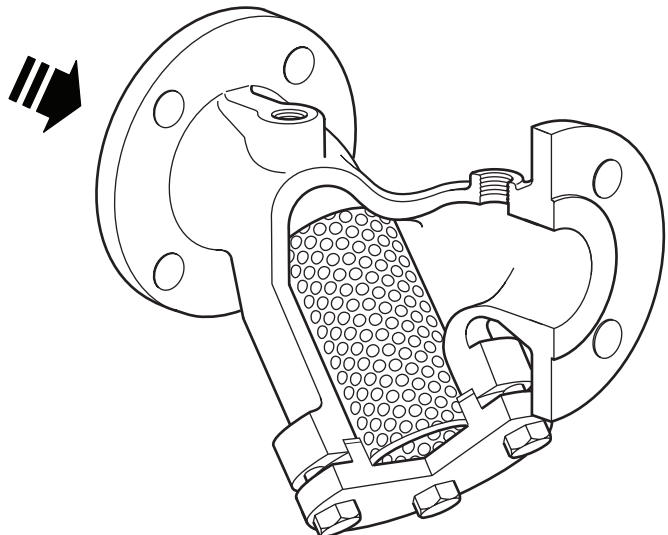

Blowdown, drain valve and pressure connections

The cap can be tapped to enable a blowdown or drain valve to be fitted. The body can be drilled for pressure tapplings. These options are available at extra cost.

Connection sizes are as shown below:

Strainer size	Blowdown valve	Drain valve	Pressure tapping
½" to ¾"	⅜"	⅜"	¼"
1" to 1¼"	½"	½"	¼"
1½" to 3"	¾"	¾"	¼"
4" to 8"	1"	1"	¼"

Materials

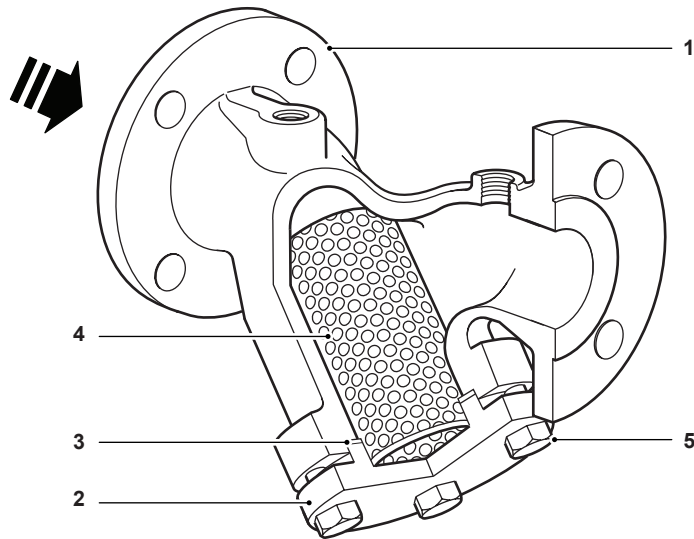

No. Part	Material
1 Body	Austenitic stainless steel ASTM A351 CF8M
2 Cap	Austenitic stainless steel ASTM A351 CF8M
3 Cap gasket	Reinforced exfoliated graphite
4 Strainer screen	Austenitic stainless steel ASTM A240 316L
5 Bolts	Austenitic stainless steel EN ISO 3506 A2 - 70

Pressure / temperature limits

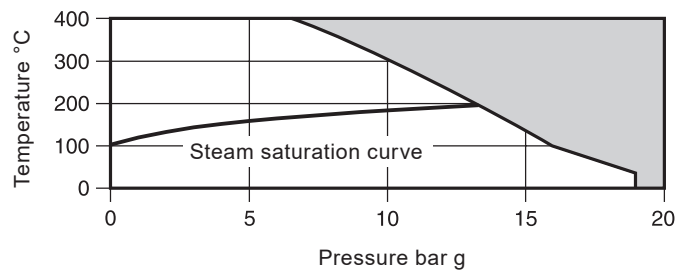

The product **must not** be used in this region.

Note: Special testing to allow lower temperature operation can be provided at extra cost. Consult Spirax Sarco.

Body design conditions	ASME (ANSI) 150
PMA Maximum allowable pressure	19 bar g (275.5 psi g)
TMA Maximum allowable temperature	400 °C (752 °F)
Minimum allowable temperature	-29 °C (-20 °F)
PMO Maximum operating pressure for saturated steam service	
TMO Maximum operating temperature	400 °C (752 °F)
Minimum operating temperature	-29 °C (-20 °F)
Product is safe for use under full vacuum conditions	
Designed for a maximum cold hydraulic test pressure of:	30 bar g (435 psi g)

Kv values

Size	1/2"	3/4"	1"	1 1/4"	1 1/2"	2"	2 1/2"	3"	4"	5"	6"	8"
Perforations 0.8, 1.6 and 3 mm	5	8	13	22	29	46	72	103	155	237	340	588
Mesh 40 and 100	5	8	13	22	29	46	72	103	155	237	340	588
Mesh 200	4	6	10	17	23	37	58	83	124	186	268	464

For conversion:

Cv (UK) = Kv x 0.963

Cv (US) = Kv x 1.156

Dimensions/weights approximate in mm (ins) and kg (lb)

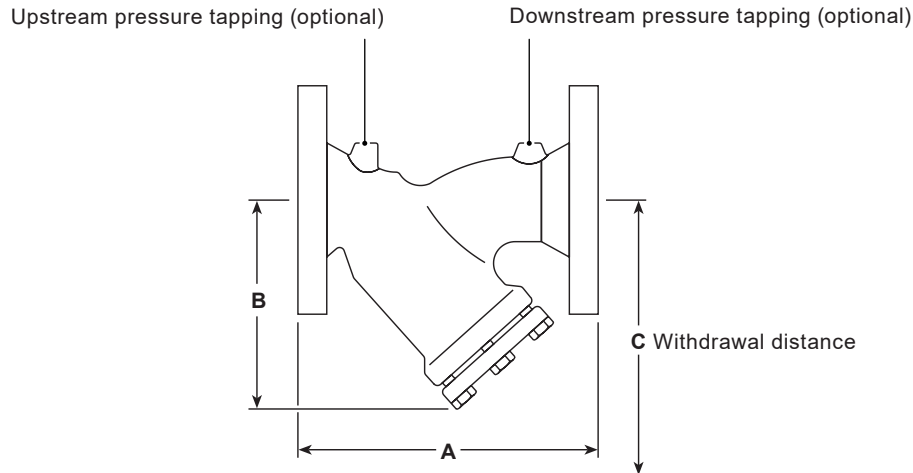

Size	ASME (ANSI) 150 A	B	C	Screening area cm ²	Weight
1/2"	135 (5.31)	69 (2.71)	101 (3.97)	28 (4.34)	2.1 (4.6)
3/4"	144 (5.66)	82 (3.22)	125 (4.92)	46 (7.13)	2.9 (6.4)
1"	154 (6.06)	90 (3.54)	140 (5.51)	79 (12.24)	3.8 (8.4)
1 1/4"	180 (7.08)	114 (4.48)	198 (7.79)	135 (20.92)	6.6 (14.5)
1 1/2"	200 (7.87)	127 (5.00)	210 (8.26)	161 (24.95)	9.0 (19.8)
2"	230 (9.05)	150 (5.90)	248 (9.76)	251 (38.90)	10.5 (23.1)
2 1/2"	290 (11.41)	162 (6.37)	263 (10.35)	325 (50.37)	17.5 (38.6)
3"	310 (12.20)	178 (7.00)	272 (10.70)	360 (55.80)	20.0 (44.1)
4"	351 (13.81)	210 (8.26)	323 (12.71)	540 (83.70)	24.0 (52.9)
5"	401 (15.78)	253 (9.96)	393 (15.47)	840 (130.20)	38.0 (83.7)
6"	473 (18.62)	293 (11.53)	454 (17.87)	1 115 (172.82)	50.5 (111.1)
8"	593 (23.34)	375 (14.76)	584 (22.99)	1 905 (295.27)	88.0 (194.0)

Safety information, installation and maintenance

For full details see the Installation and Maintenance Instructions supplied with the product.

Installation

The strainer should be installed in the direction of flow, as indicated on the body. On applications involving steam or gases the pocket should be in the horizontal plane. On liquid systems the pocket should point downwards. Suitable isolation valves must be installed to allow for safe maintenance and trap replacement.

Maintenance

Maintenance can be completed with the strainer in the pipeline.

Disposal

The product is recyclable. No ecological hazard is anticipated with disposal of this product, providing due care is taken.

How to order

Example: 1 off Spirax Sarco 1½" Fig 3616 strainer, flanged ASME (ANSI) 150 with austenitic stainless steel screen having 0.8 mm perforations and flanged screen cap.

Spare parts

The spare parts available are shown in solid outline. Parts drawn in a grey line are not supplied as spares.

Available spares

Strainer screen (state material, perforations or mesh and size of strainer)				4
Cap gasket	½" to 8"	(3 off)		3
	5" to 8"	(1 off)		3



How to order spares

Always order spares by using the description given in the column headed 'Available spares' and state the size and type of strainer and perforation or mesh required.

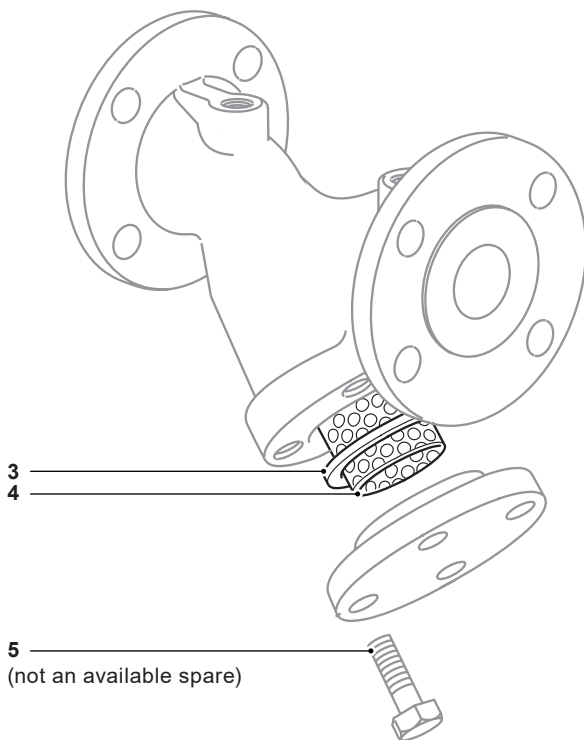
Example: 1 - stainless steel strainer screen, having 0.8 mm perforations for a 2" Spirax Sarco Fig 3616 strainer having flanged ASME (ANSI) 150 connections.



Recommended tightening torques

Item	Size	Qty	or		N m	(lbf ft)
						
5	½"	4	13 A/F	M8 x 20	15 - 20	(11 - 15)
	¾"	4	13 A/F	M8 x 20	15 - 20	(11 - 15)
	1"	4	13 A/F	M8 x 20	15 - 20	(11 - 15)
	1¼"	4	13 A/F	M8 x 20	15 - 20	(11 - 15)
	1½"	4	13 A/F	M8 x 20	15 - 20	(11 - 15)
	2"	4	16 A/F	M10 x 25	22 - 25	(16 - 18)
	2½"	4	17 A/F	M10 x 30	22 - 25	(16 - 18)
	3"	6	17 A/F	M10 x 30	22 - 25	(16 - 18)
	4"	6	18 A/F	M12 x 35	50 - 60	(36 - 44)
	5"	8	19 A/F	M12 x 40	50 - 60	(36 - 44)
	6"	8	19 A/F	M12 x 40	50 - 60	(36 - 44)
	8"	8	24 A/F	M16 x 50	100 - 110	(73 - 80)