



Fig 34 Carbon Steel 'Y' Type Strainer - DN250 to DN400 (10" to 16")

Description

The Fig 34 is an integrally flanged Y-type strainer designed to remove rust, scale and other debris from the pipeline. The standard stainless steel screen is 3 mm perforations.

Standards

This product fully complies with the requirements of the European Pressure Equipment Directive 2014/68/EU and carries the

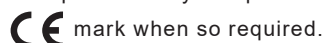

Certification

The product is available with material certification to EN 10204 3.1 for body and cover.

Note: All certification/inspection requirements must be stated at the time of order placement.

Optional extras

	Perforations:	0.8 mm, 1.6 mm and 5 mm
Strainer screens	Mesh:	40, 100 and 200
	Monel screen:	Available on request

Blowdown or drain valve connections

The cap can be drilled to the following sizes to enable a blowdown or drain valve to be fitted.

Strainer size	Blowdown valve	Drain valve
DN250 to DN400	2"	2"

Sizes and pipe connections

DN250, DN300, DN350 and DN400

Available standard flanged connections:

- EN 1092 PN40, PN25 and PN16.
- ASME B 16.5 Class 150 and ASME B 16.5 Class 300.
- JIS/KS 10 and JIS/KS 20.

As standard all flanges are supplied with a raised face. Alternative flange facing can be supplied on request and must also be specified at the point of order placement.

Kv values

Size	DN250	DN300	DN350	DN400
Perforated	950	1300	1800	2300
Mesh	850	1100	1500	1900

For conversion:

Cv (UK) = Kv x 0.963

Cv (US) = Kv x 1.156

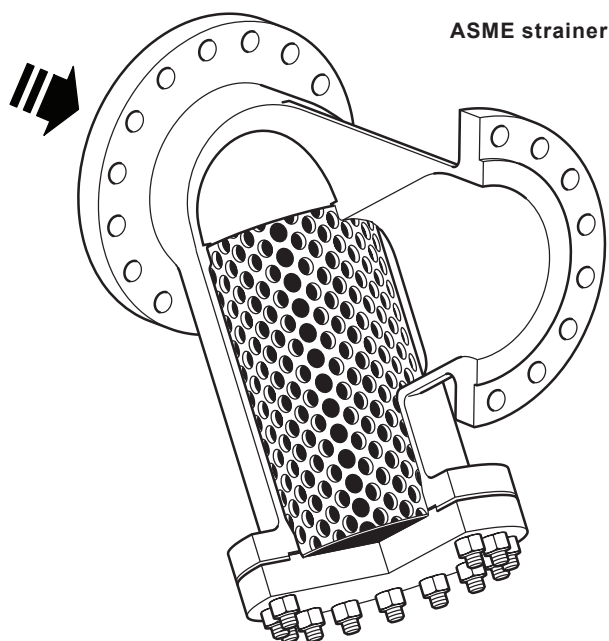
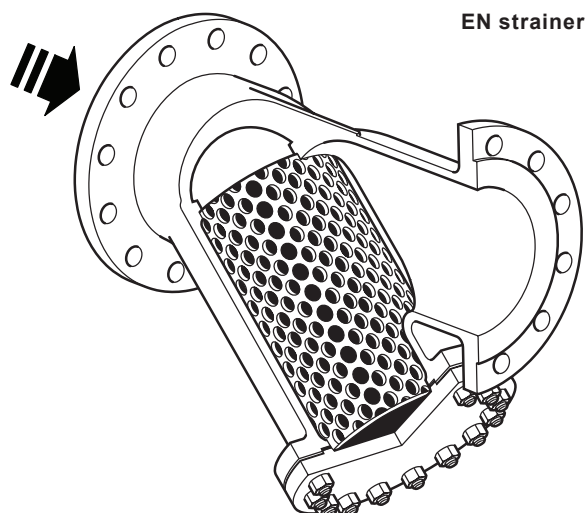

Materials

EN strainer

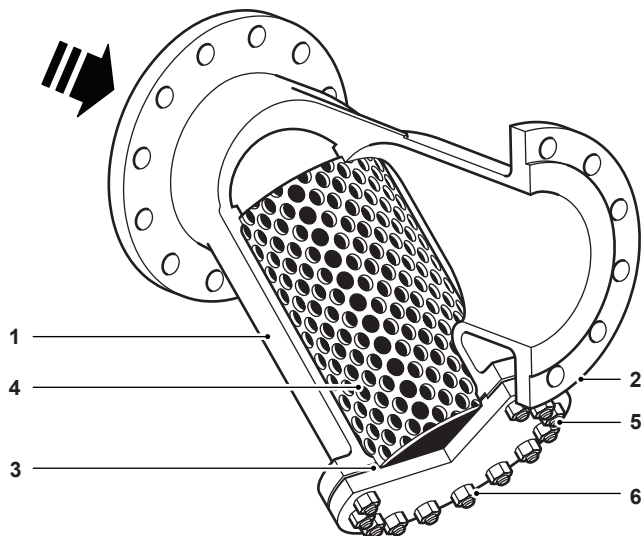

ASME strainer

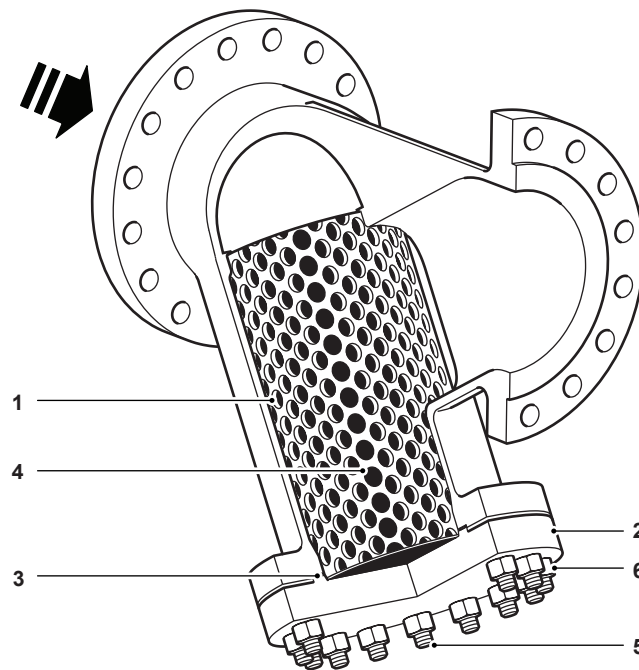

No.	Part	Material	
1	Body	Carbon steel	EN 10213 : 1.0619+N/ASTM A216 WCB
2	Cover	Carbon steel	EN 10213 : 1.0619+N/ASTM A216 WCB or ASTM A105N
3	Gasket	Reinforced exfoliated graphite	
4	Screen	Stainless steel	
5	Stud	Carbon steel	ASTM A193 B7
6	Nut	Carbon steel	ASTM A194 2H

Pressure/temperature limits

EN

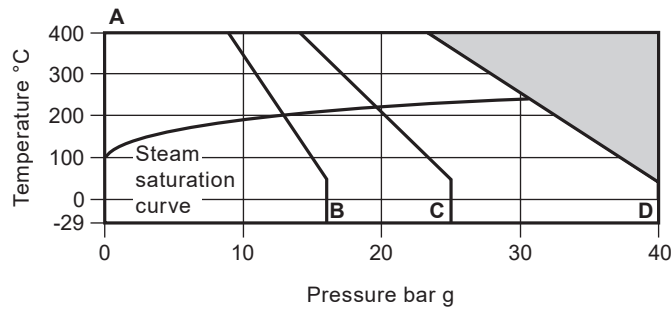

The product **must not** be used in this region.

- A - B Flanged EN 1092 PN16
 - A - C Flanged EN 1092 PN25
 - A - D Flanged EN 1092 PN40
- } PMA and TMA

Body design conditions		PN40
PMA	Maximum allowable pressure	PN40 40 bar g @ 50 °C
		PN25 25 bar g @ 50 °C
		PN16 16 bar g @ 50 °C
TMA	Maximum allowable temperature	PN40 400 °C @ 23.8 bar g
		PN25 400 °C @ 14.8 bar g
		PN16 400 °C @ 9.5 bar g
Minimum allowable temperature		-29 °C
PMO	Maximum operating pressure for saturated steam service	PN40 30.7 bar g @ 237 °C
		PN25 20 bar g @ 215 °C
		PN16 13.2 bar g @ 196 °C
TMO	Maximum operating temperature	PN40 400 °C @ 23.8 bar g
		PN25 400 °C @ 14.8 bar g
		PN16 400 °C @ 9.5 bar g
Minimum operating temperature		-29 °C
Product is safe for use under full vacuum conditions		
Designed for a maximum cold hydraulic test pressure of 1.5 x PMA		

Pressure/temperature limits

ASME

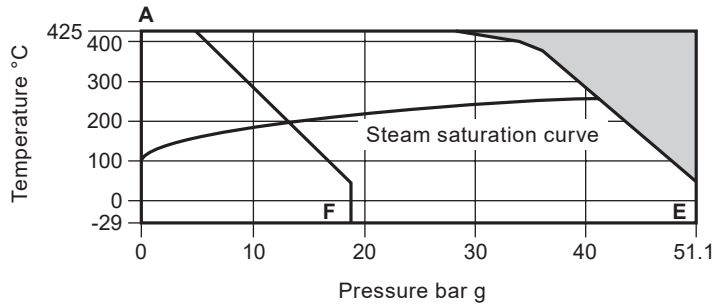

The product **must not** be used in this region.

A - E Flanged ASME Class 300
A - F Flanged ASME Class 150

PMA and TMA

Body design conditions		ASME Class 300	
PMA	Maximum allowable pressure	ASME 300	51.1 bar g @ 38 °C
		ASME 150	19.6 bar g @ 38 °C
TMA	Maximum allowable temperature	ASME 300	425 °C @ 28.8 bar g
		ASME 150	425 °C @ 5.5 bar g
Minimum allowable temperature		-29 °C	
PMO	Maximum operating pressure for saturated steam service	ASME 300	41.5 bar g @ 254 °C
		ASME 150	13.6 bar g @ 197 °C
TMO	Maximum operating temperature	ASME 300	425 °C @ 28.8 bar g
		ASME 150	425 °C @ 5.5 bar g
Minimum operating temperature		-29 °C	
Product is safe for use under full vacuum conditions			
Designed for a maximum cold hydraulic test pressure of 1.5 x PMA			

Pressure/temperature limits

JIS/KS

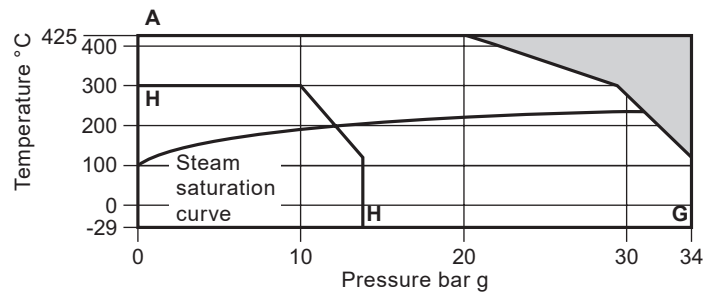

The product **must not** be used in this region.

A - G Flanged JIS/KS 20

A - H Flanged JIS/KS 10

PMA and TMA

Body design conditions		PN40	
PMA	Maximum allowable pressure	JIS/KS 20	34 bar g @ 120 °C
		JIS/KS 10	14 bar g @ 120 °C
TMA	Maximum allowable temperature	JIS/KS 20	425 °C @ 20.0 bar g
		JIS/KS 10	300 °C @ 10.0 bar g
Minimum allowable temperature		-29 °C	
PMO	Maximum operating pressure for saturated steam service	JIS/KS 20	30.1 bar g @ 236 °C
		JIS/KS 10	12.4 bar g @ 193 °C
TMO	Maximum operating temperature	JIS/KS 20	425 °C @ 20.0 bar g
		JIS/KS 10	300 °C @ 10.0 bar g
Minimum operating temperature		-29 °C	
Product is safe for use under full vacuum conditions			
Designed for a maximum cold hydraulic test pressure of 1.5 x PMA			

Dimensions/weights
(approximate) in mm and kg

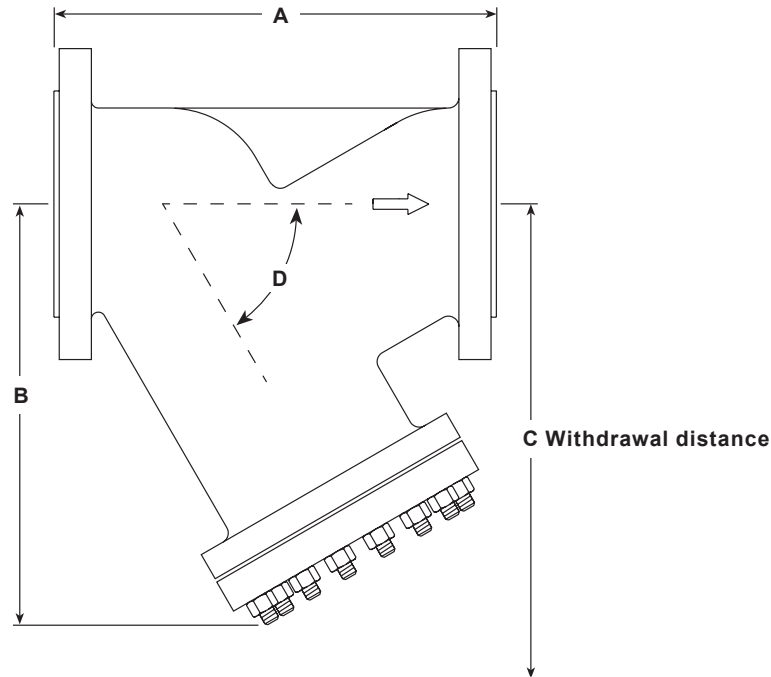

Size	A			B	C	D	Screening area mm ²	Weight (Kg)							
	EN and JIS/KS	ASME 150	ASME 300					PN40	PN25	PN16	JIS/KS 20	JIS/KS 10	ASME 150	ASME 300	
DN250	EN	730	622	622	515	957	45°	371 800	212	197	187	202	185	163	218
	ASME	730	622	622	560	1005	60°	371 800							
DN300	EN	850	699	711	570	1020	45°	439 300	259	236	222	238	214	270	344
	ASME	850	699	711	640	1098	60°	439 300							
DN350	EN	980	787	838	620	1205	45°	653 400	448	419	396	414	377	380	454
	ASME	980	787	838	770	1320	60°	593 800							
DN400	EN	1 100	914	864	710	1340	60°	641 400	600	547	513	548	498	487	617
	ASME	1 100	914	864	730	1360	60°	641 400							

Safety information, installation and maintenance

For full details see the Installation and Maintenance Instructions (IM-S60-18) supplied with the product.

Installation note

The strainer should be installed in the direction of flow, as indicated on the body. On applications involving steam or gases the pocket should be in the horizontal plane. On liquid systems the pocket should point downwards.

Warning

The strainer cover gasket contains a thin stainless steel support ring, which may cause physical injury if not handled and disposed of carefully.

Disposal

The product is recyclable. No ecological hazard is anticipated with disposal of this product, providing due care is taken.

How to order

Example:

1 off Spirax Sarco DN350 Fig 34 strainer having flanged ASME Class 300 connections with a stainless steel screen having 3 mm perforations.

Spare parts

The spare parts available are shown in solid outline. Parts drawn in a grey line are not supplied as spares.

Available spares

Strainer screen	(state material, perforations or mesh and size of strainer)	4
Cover gasket	(packet of 3)	3



How to order spares

Always order spares by using the description given in the column headed 'Available spares' and state the size and type of strainer and perforation or mesh required.

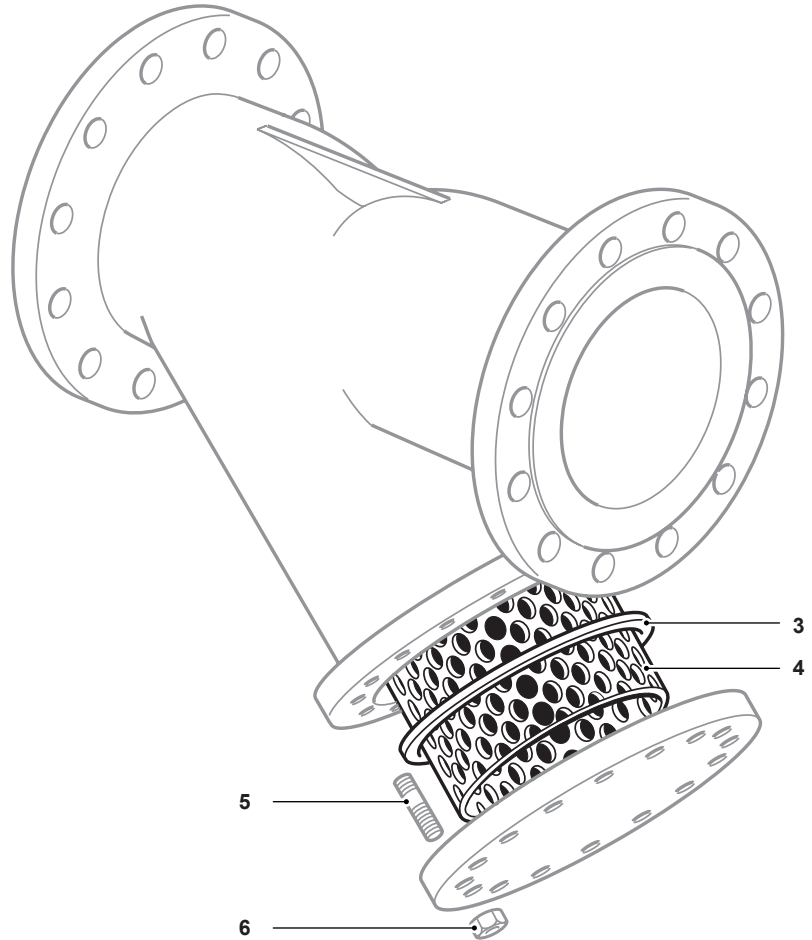
Example: 1 off Strainer screen, stainless steel having 0.8 mm perforations for a DN250 Spirax Sarco Fig 34 strainer having ASME Class 300 connections.



Recommended tightening torques

Item	Size	Connections	Quantity		or mm		N m
5 and 6	DN250 (10")	ASME Class 150 and EN	16	1¼"		¾" - 10UNC	160 - 180
		ASME Class 300	16	1⅞"		7⁄8" - 9UNC	180 - 200
	DN300 (12")	ASME Class 150 and EN	16	1¼"		¾" - 10UNC	200 - 220
		ASME Class 300	18	1⅞"		7⁄8" - 9UNC	210 - 230
	DN350 (14")	ASME Class 150 and EN	20	1¼"		¾" - 10UNC	220 - 240
		ASME Class 300	22	1⅞"		7⁄8" - 9UNC	230 - 250
DN400 (16")	ASME Class 150 and EN	22	1⅞"		7⁄8" - 9UNC	330 - 350	
	ASME Class 300	16	1⅞"		1⅞"	7UNC	480 - 530