



## Fig 16HP Stainless Steel Strainer

### Description

The Fig 16HP is a stainless steel Y-type strainer designed to remove scale, rust and other debris from the pipeline. The standard stainless steel screen is 0.8 mm perforations.

### Standards

This product fully complies with the requirements of the EU Pressure Equipment Directive/UK Pressure Equipment (Safety) Regulations.

### Certification

The product is available with a manufacturer's Typical Test Report for the body and cap as standard and EN 10204 3.1 to special order at extra cost.

**Note:** All certification/inspection requirements must be stated at the time of order placement.

### Sizes and pipe connections

1/4", 3/8", 1/2", 3/4", 1", 1 1/4" 1 1/2" and 2"

Screwed BSP or NPT

Socket weld ends to BS 3799 Class 3000 lb

### Optional extras

#### Strainer screens

	Perforations	1.6 mm and 3.0 mm
Stainless steel screen	Mesh	40, 100 and 200
	Perforations	0.8 mm and 3.0 mm
Monel screen	Mesh	100

#### Blowdown or drain valve connections

The cap can be drilled to the following sizes to enable a blowdown or drain valve to be fitted at extra cost.

Strainer size	Blowdown valve	Drain valve
1/4", 3/8" and 1/2"	1/4"	1/4"
3/4" and 1"	1/2"	1/2"
1 1/4" and 1 1/2"	1"	3/4"
2"	1 1/4"	3/4"

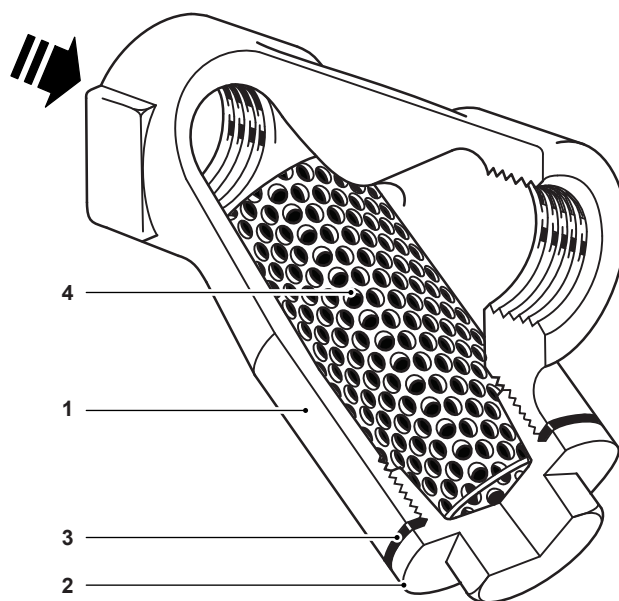

### Materials

No.	Part	Material
1	Body	1/4" to 1/2" Stainless steel A182 F316L/1.4404
		3/4" to 2" Stainless steel ASTM A351 CF8M/1.4408
2	Cap	Stainless steel ASTM A351 CF3M/1.4409
3	Cap gasket	Reinforced exfoliated graphite
4	Strainer screen	Stainless steel A240 316L

## Pressure/temperature limits

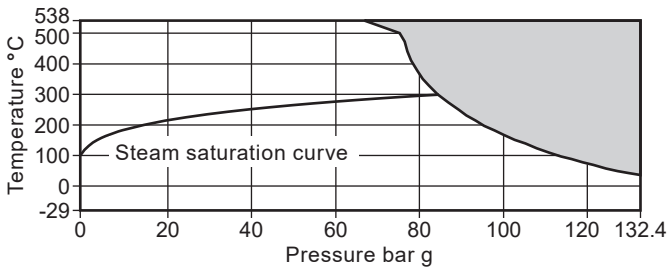

The product **must not** be used in this region.

Body design conditions		ASME Class 800
PMA	Maximum allowable pressure	132.4 bar g @ 38 °C
TMA	Maximum allowable temperature	538 °C @ 66.8 bar g
Minimum allowable temperature		-29 °C
PMO	Maximum operating pressure for saturated steam service	85 bar g @ 300 °C
TMO	Maximum operating temperature	538 °C @ 66.8 bar g
Minimum operating temperature		-29 °C
<b>Note:</b> For lower operating temperatures consult Spirax Sarco.		
Designed for a maximum cold hydraulic test pressure of:		200 bar g

## Dimensions/weights (approximate) in mm and kg

Size	A	B	C	D	Screening area cm <sup>2</sup>	Weight
¼"	70	51	80	32	27	0.43
⅜"	70	51	80	32	27	0.49
½"	73	52	81	32	27	0.56
¾"	90	64	100	36	43	0.72
1"	105	74	120	46	73	1.17
1¼"	140	102	164	60	135	2.35
1½"	152	115	184	70	164	3.30
2"	178	138	224	80	251	4.95

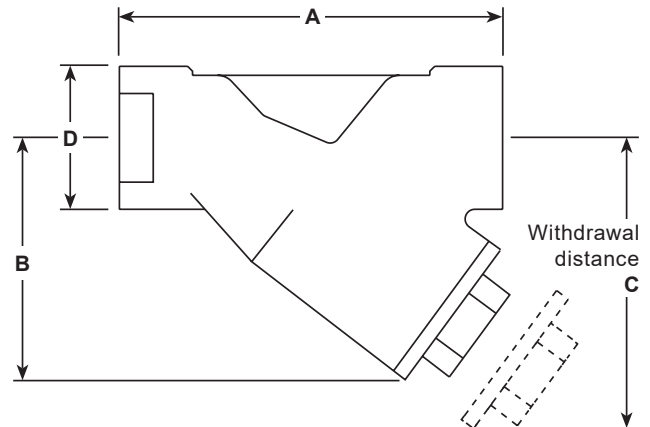

## Kv values

Size	¼"	⅜"	½"	¾"	1"	1¼"	1½"	2"
<b>Perforations 0.8, 1.6 and 3 mm</b>	1	2.6	3.6	11	15.5	26	41	68
<b>Mesh 40 and 100</b>	1	2.6	3.6	11	15.5	26	41	68
<b>Mesh 200</b>	1	2.6	2.6	9	13.0	21	35	55

For conversion:

$$Cv (UK) = Kv \times 0.963$$

$$Cv (US) = Kv \times 1.156$$

## Safety information, installation and maintenance

For full details see the Installation and Maintenance Instructions (IM-S60-17) supplied with the product.

### Warning:

The strainer cap gasket contains a thin stainless steel support ring, which may cause physical injury if not handled and disposed of carefully.

### Disposal

The product is recyclable. No ecological hazard is anticipated with disposal of this product, providing due care is taken.

### How to order

**Example:** 1 off Spirax Sarco 1½" Fig 16HP strainer having screwed BSP connections with a stainless steel screen having 0.8 mm perforations.

### Spare parts

The spare parts available are shown in solid outline. Parts drawn in a grey line are not supplied as spares.

### Available spares

Strainer screen (state material, perforations or mesh and size of strainer)	<b>4</b>
Cap gasket (packet of 3)	<b>3</b>

### How to order spares



Always order spares by using the description given in the column headed 'Available spares' and state the size and type of strainer and perforation or mesh required.

**Example:** 1 off Stainless steel strainer screen having 0.8 mm perforations for a ¾" Spirax Sarco Fig 16HP strainer.

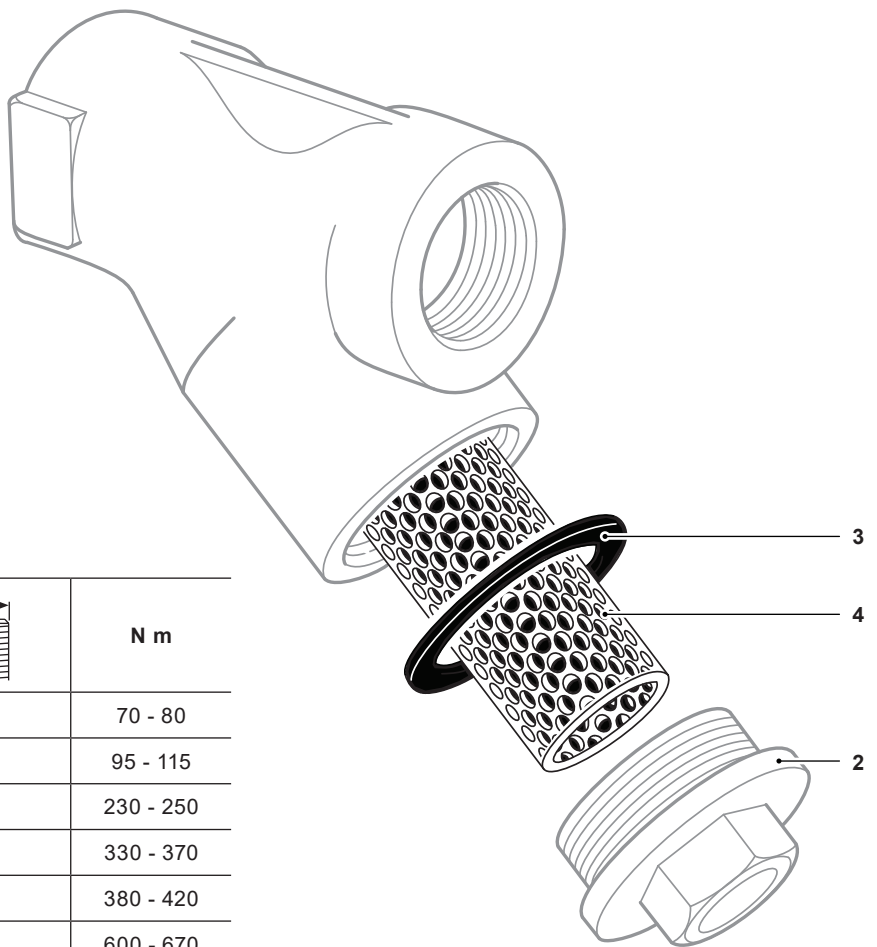
**Note:** When replacing the strainer cap coat the thread only with anti-seize compound, making sure none gets on the gasket or gasket faces.



### Recommended tightening torques

Item Size	 or 	mm	N m
<b>2</b>	¼", ⅝" and ½"	22 A/F	70 - 80
	¾"	27 A/F	95 - 115
	1"	32 A/F	230 - 250
	1¼"	46 A/F	330 - 370
	1½"	50 A/F	380 - 420
	2"	60 A/F	600 - 670