



## Fig 16, Fig 16L and Fig 16L Food+ Austenitic Stainless Steel Strainers



### Description

The Fig 16 and Fig 16L are austenitic stainless steel screwed Y-type strainers. The Fig 16 is 316 and the Fig 16L is 316L. The standard stainless steel screen is 0.8 mm perforations.

As options, other perforations and mesh sizes are available as well as monel screens.

The strainer cap can be drilled and tapped for blowdown and drain valves if required.

### Standards

This products complies with the requirements of the EU Pressure Equipment Directive/UK Pressure Equipment (Safety) Regulations and carries the  /  mark when so required.

### Certification

The Fig 16 is available with a manufacturers Typical Test Report. The Fig 16L is available with certification to EN 10204 3.1.

**Note:** All certification/inspection requirements must be stated at the time of order placement.

Food+ can be supplied with material Certification for all wetted parts at extra cost.

**Note:** All certification/inspection requirements must be stated at the time of order placement.

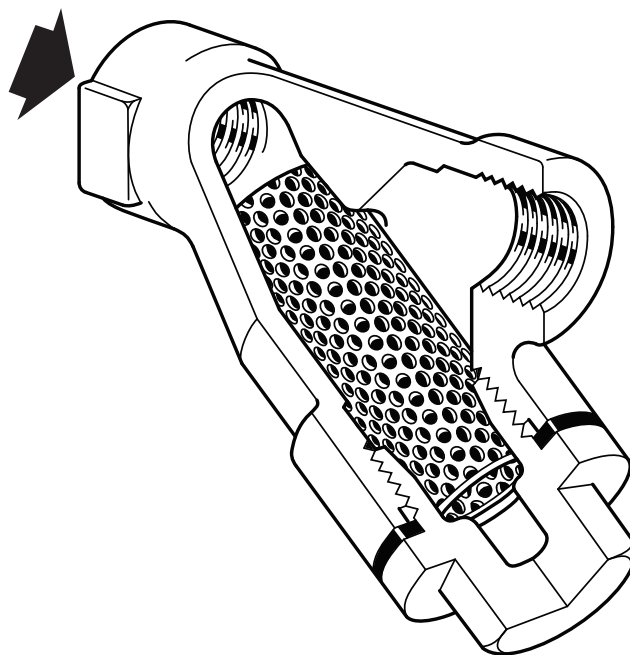

### Fig 16L Food+ ½" to 2" is available with a food contact regulation Declaration of Compliance

Designed, manufactured and approved for Steam and Condensate applications, the Fig 16L Food+ product complies with:

- (EC)1935:2004 Materials and Articles Intended to come into Contact with Food
- (EC)2023:2006 Good Manufacturing Practice for Materials and Articles Intended to come into Contact with Food
- (EU)10/2011 Plastic Materials and Articles Intended to come into Contact with Food
- FDA Code of Federal Regulations - title 21 - Food and Drugs

This product is intended to be connected into a system that can operate a food contact compliant process.

A list of the materials that could come directly or indirectly into contact with foodstuffs can be found in the Declaration of Compliance supplied with this product.

### Sizes and pipe connections

¾", ½", ¾", 1", 1¼", 1½" and 2"

Screwed BSP or NPT

Socket weld ends to BS 3799 Class 3000 lb (Fig 16L only).

## Optional extras

Strainer screens	Stainless steel screens	Perforations	1.6 mm and 3 mm
		Mesh	40, 100 and 200
	Monel screens	Perforations	0.8 mm and 3 mm
		Mesh	100

### Blowdown or drain valve connections

The cap can be drilled to the following sizes to enable a blowdown or drain valve to be fitted at extra cost.

Strainer size	Blowdown valve	Drain valve
3/8" and 1/2"	1/4"	1/4"
3/4"	1/2"	3/8"
1"	1/2"	1/2"
1 1/4" and 1 1/2"	1"	3/4"
2"	1 1/4"	3/4"

## Materials

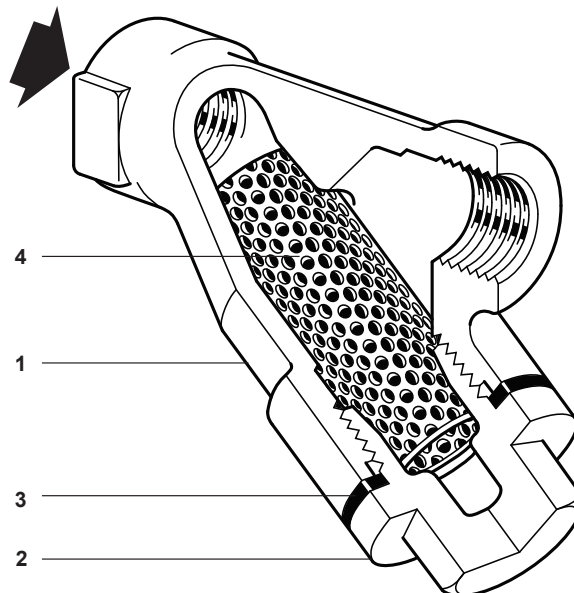

No.	Part	Material
1	Body Fig 16	Austenitic stainless steel ASTM A351 Gr. CF8M (316)
	Fig 16L	Austenitic stainless steel ASTM A351 Gr. CF3M (316L)
2	Cap Fig 16	Austenitic stainless steel ASTM A351 Gr. CF8M (316)
	Fig 16L	Austenitic stainless steel ASTM A351 Gr. CF3M (316L)
3	Cap gasket	Reinforced exfoliated graphite or PTFE on EC1935/2004 version
4	Strainer screen	Austenitic stainless steel 316L

## Pressure/temperature limits

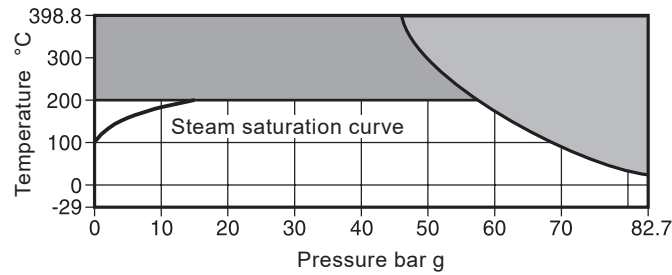

The product **must not** be used in this region.

EC1935/2004 product must not be used in this region.

Body design conditions		ANSI 600
PMA	Maximum allowable pressure	82.7 bar g @ 37.7 °C
	Maximum allowable temperature	398.8 °C @ 46.2 bar g
TMA	Maximum EC1935/2004 allowable temperature	200 °C @ 13.7 bar g
	Minimum allowable temperature	-29 °C
PMO	Maximum operating pressure	82.7 bar g @ 37.7 °C
	Maximum operating temperature	398.8 °C @ 46.2 bar g
TMO	Maximum EC1935/2004 allowable temperature	200°C @ 13.7 bar g
	Minimum operating temperature	-29 °C
<b>Note:</b> For lower operating temperatures consult Spirax Sarco		
Designed for a maximum cold hydraulic test pressure of:		125 bar g

## Kv values

Size	¼"	⅜"	½"	¾"	1"	1¼"	1½"	2"
<b>Perforations 0.8, 1.6 and 3 mm</b>	1	2.6	3.6	11	15.5	26	41	68
<b>Mesh 40 and 100</b>	1	2.6	3.6	11	15.5	26	41	68
<b>Mesh 200</b>	1	2.6	2.6	9	13.0	21	33	55

For conversion:

$$Cv \text{ (UK)} = Kv \times 0.963$$

$$Cv \text{ (US)} = Kv \times 1.156$$

## Dimensions/weights (approximate) in mm and kg

Size	A	B	C	D	Screening area cm <sup>2</sup>	Weight kg
⅜"	69	55	87	26	25	0.32
½"	76	55	87	32	25	0.38
¾"	88	65	110	38	42	0.51
1"	106	78	125	46	71	0.87
1¼"	133	103	155	56	135	1.56
1½"	146	115	190	62	161	2.10
2"	172	140	230	76	251	3.46

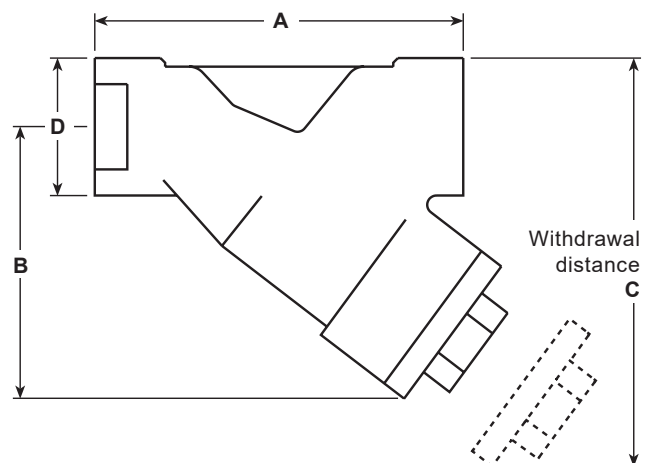

## Safety information, installation and maintenance

For full details see the Installation and Maintenance Instructions (IM-S60-17) supplied with the product.

### Warning:

The strainer cap gasket contains a thin stainless steel support ring, which may cause physical injury if not handled and disposed of carefully.

### Disposal

The product is recyclable. No ecological hazard is anticipated with disposal of this product, providing due care is taken.

## How to order

**Example:** 1 off Spirax Sarco 1½" Fig 16 strainer with screwed BSP connections and a stainless steel screen having 0.8 mm perforations.

## Spare parts

The spare parts available are shown in solid outline. Parts drawn in a grey line are not supplied as spares.

### Available spares

Strainer screen (always state material, size of perforation/mesh and size of strainer)	<b>4</b>
Cap gasket (packet of 3)	<b>3</b>
EC1935/2004 Cap gasket - ½" to 2" (3 off)	<b>3</b>



### How to order spares

Always order spares by using the description given in the column headed 'Available spares' and state the size and type of strainer and perforation or mesh required.

**Example:** 1 off Stainless steel strainer screen, having 1.6 mm perforations, for a ¾" Spirax Sarco Fig 16 strainer with screwed BSP connections.

**Note:** When replacing the strainer cap coat the thread only with anti-seize compound, making sure none gets on the gasket or gasket faces.

### Recommended tightening torques

Item	Size	 or mm		N m
	¾"	22 A/F		45 - 50
	½"	22 A/F		45 - 50
	¾"	27 A/F		60 - 66
<b>2</b>	1"	27 A/F		100 - 110
	1¼"	46 A/F		240 - 260
	1½"	46 A/F		260 - 280
	2"	60 A/F		310 - 340

