



## Fig 14HP Carbon Steel Strainer

### Description

The Fig 14HP is a carbon steel Y-type strainer designed to remove scale, rust and other debris from the pipeline. The standard stainless steel screen is 0.8 mm perforations.

### Standards

This product fully complies with the requirements of the EU Pressure Equipment Directive/UK Pressure Equipment (Safety) Regulations and carries the  mark when so required.

### Certification

The product is available with a manufacturer's Typical Test Report for the body and cap as standard and EN 10204 3.1 to special order at extra cost.

**Note:** All certification/inspection requirements must be stated at the time of order placement.

### Sizes and pipe connections

1/4", 3/8", 1/2", 3/4", 1", 1 1/4", 1 1/2" and 2"

Screwed BSP or NPT

Socket weld ends to BS 3799 Class 3000 lb

### Optional extras

#### Strainer screens

|                        |              |                   |
|------------------------|--------------|-------------------|
| Stainless steel screen | Perforations | 1.6 mm and 3.0 mm |
|                        | Mesh         | 40, 100 and 200   |
| Monel screen           | Perforations | 0.8 mm and 3.0 mm |
|                        | Mesh         | 100               |

#### Blowdown or drain valve connections

The cap can be drilled to the following sizes to enable a blowdown or drain valve to be fitted at extra cost.

| Strainer size       | Blowdown valve | Drain valve |
|---------------------|----------------|-------------|
| 1/4", 3/8" and 1/2" | 1/4"           | 1/4"        |
| 3/4" and 1"         | 1/2"           | 1/2"        |
| 1 1/4" and 1 1/2"   | 1"             | 3/4"        |
| 2"                  | 1 1/4"         | 3/4"        |

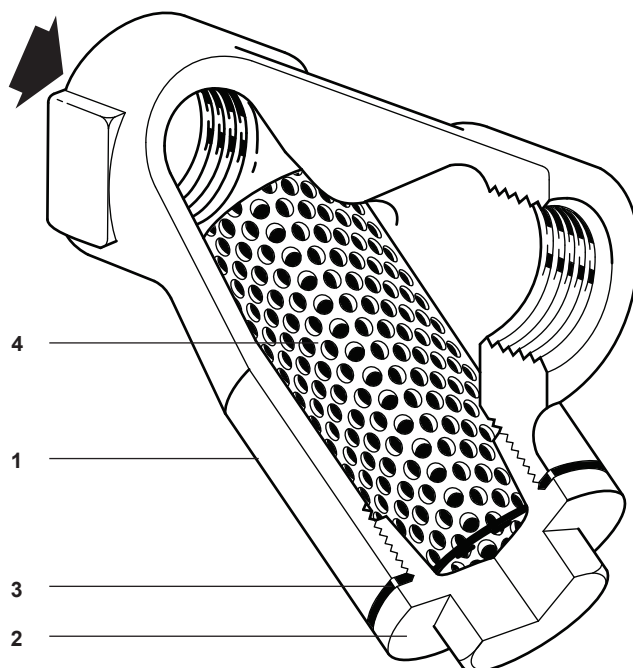

### Materials

| No. | Part            | Material   |
|-----|-----------------|--|
| 1   | Body            | 1/4" and 1/2" Carbon steel ASTM A105N/1.0460     |
|     |                 | 3/4" to 2" Carbon steel ASTM A216 WCB/1.0619 + N |
| 2   | Cap             | Carbon steel ASTM A105N/1.0460                   |
| 3   | Cap gasket      | Reinforced exfoliated graphite                   |
| 4   | Strainer screen | Stainless steel A240 316L                        |

## Pressure/temperature limits

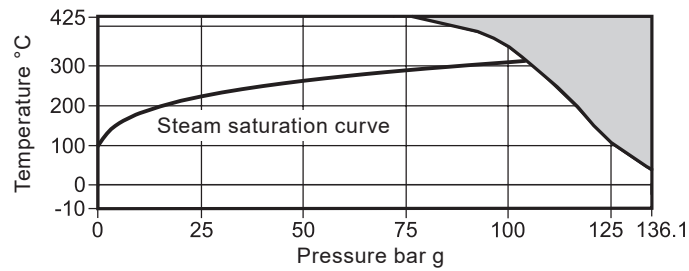

The product **must not** be used in this region.

|  |                     |
|--|---------------------|
| Body design conditions   | ASME Class 800      |
| PMA Maximum allowable pressure                                     | 136.1 bar g @ 38 °C |
| TMA Maximum allowable temperature                                  | 425 °C @ 76.7 bar g |
| Minimum allowable temperature                                      | -29 °C              |
| PMO Maximum operating pressure                                     | 136.1 bar g @ 38 °C |
| TMO Maximum operating temperature                                  | 425 °C @ 76.7 bar g |
| Minimum operating temperature                                      | -29 °C              |
| <b>Note:</b> For lower operating temperatures consult Spirax Sarco |                     |
| Designed for a maximum cold hydraulic test pressure of             | 205 bar g           |

## Kv values

| Size                           | 1/4" | 3/8" | 1/2" | 3/4" | 1"   | 1 1/4" | 1 1/2" | 2" |
|--------------------------------|------|------|------|------|------|--------|--------|----|
| Perforations 0.8, 1.6 and 3 mm | 1    | 2.6  | 3.6  | 11   | 15.5 | 26     | 41     | 68 |
| Mesh 40 and 100                | 1    | 2.6  | 3.6  | 11   | 15.5 | 26     | 41     | 68 |
| Mesh 200                       | 1    | 2.6  | 2.6  | 9    | 13.0 | 21     | 35     | 55 |

For conversion:

$$Cv (UK) = Kv \times 0.963$$

$$Cv (US) = Kv \times 1.156$$

## Dimensions/weights (approximate) in mm and kg

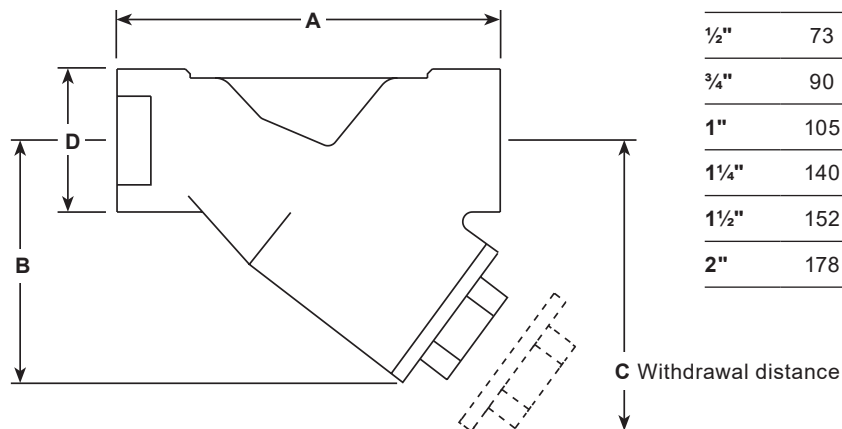

| Size   | A   | B   | C   | D  | Screening area cm <sup>2</sup> | Weight |
|--------|-----|-----|-----|----|--------------------------------|--------|
| 1/4"   | 70  | 51  | 80  | 32 | 27                             | 0.43   |
| 3/8"   | 70  | 51  | 80  | 32 | 27                             | 0.49   |
| 1/2"   | 73  | 52  | 81  | 32 | 27                             | 0.56   |
| 3/4"   | 90  | 64  | 100 | 36 | 43                             | 0.72   |
| 1"     | 105 | 74  | 120 | 46 | 73                             | 1.17   |
| 1 1/4" | 140 | 102 | 164 | 60 | 135                            | 2.35   |
| 1 1/2" | 152 | 115 | 184 | 70 | 164                            | 3.30   |
| 2"     | 178 | 138 | 224 | 80 | 251                            | 4.95   |

## Safety information, installation and maintenance

For full details see the Installation and Maintenance Instructions (IM-S26-01-EN-ISS1) supplied with the product.

### Warning:

The strainer cap gasket contains a thin stainless steel support ring, which may cause physical injury if not handled and disposed of carefully.

### Disposal

The product is recyclable. No ecological hazard is anticipated with disposal of this product, providing due care is taken.

### How to order

**Example:** 1 off Spirax Sarco 1½" Fig 14HP strainer having screwed BSP connections with a stainless steel screen having 0.8 mm perforations.

### Spare parts

The spare parts available are shown in solid outline. Parts drawn in a grey line are not supplied as spares.

### Available spares

|   |   |
|---|---|
| Strainer screen (state material, perforations or mesh and size of strainer) | 4 |
| Cap gasket (packet of 3)  | 3 |

### How to order spares



Always order spares by using the description given in the column headed 'Available spares' and state the size and type of strainer and perforation or mesh required.

**Example:** 1 off Stainless steel strainer screen having 0.8 mm perforations for a ¾" Spirax Sarco Fig 14HP strainer.

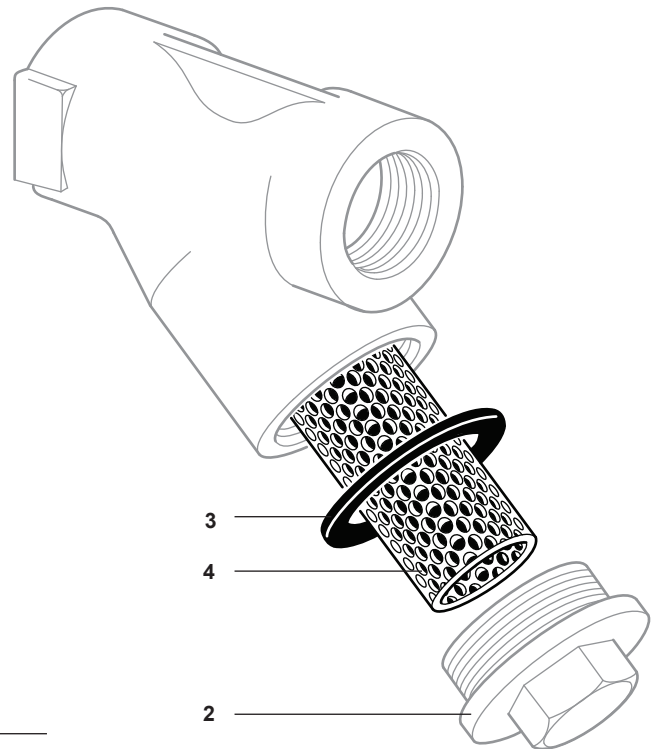
**Note:** When replacing the strainer cap coat the thread only with anti-seize compound, making sure none gets on the gasket or gasket faces.



### Recommended tightening torques

| Item | Size          |  or <br>mm | N m       |
|------|---------------|--|-----------|
| 2    | ¼", ⅜" and ½" | 36 A/F   | 50 - 55   |
|      | ¾"            | 38 A/F   | 60 - 66   |
|      | 1"            | 50 A/F   | 100 - 110 |
|      | 1¼"           | 46 A/F   | 180 - 200 |
|      | 1½"           | 50 A/F   | 230 - 250 |
|      | 2"            | 60 A/F   | 330 - 360 |