



EL2600

Pressure Transmitter and 'U' Syphons

Description

The EL2600 is a combined pressure sensor and transmitter which is designed for general and industrial use. It has a 2-wire 4-20 mA current loop, and a 1/4" NPT process connection. Two syphon tube and valve assemblies are available, one with a maximum design pressure of 25 bar g (362 psi g) and, and one with a maximum design pressure of 80 bar g (1160 psi g.).

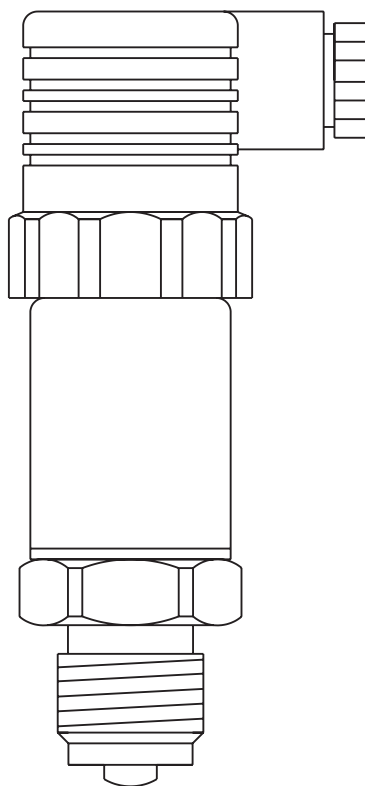

Available ranges

m bar g	0-100	0-250	0-600					
(m psi g)	(0- 1450)	(0-3625)	(0-8702)					
bar g	0-0.1	0-0.25	0-0.6	0-1	0-1.6	0-2.5	0-4	0-6
(psi g)	(0-1.45)	(0-3.62)	(0-8.7)	(0-14.5)	(0-23.2)	(0-36.2)	(0-58)	(0-87)
bar g	0-10	0-16	0-25	0-40	0-60	0-100*	0-160*	0-250*
(psi g)	(0-145)	(0-232)	(0-362)	(0-580)	(0-870)	(0-1450)	(0-2320)	(0-3,625)
bar a	0-1.6	0-2.5						
(psi a)	(0-23.2)	(0-36.2)						

* No 'U' syphon is available for these ranges, therefore maximum operating temperature is limited to 100 °C

Limiting conditions

Pressure/temperature limits EL2600

Minimum operating temperature	Medium	-30 °C (-22 °F)
	Ambient	-20 °C (-4 °F)
Maximum operating temperature (without syphon tube)	Medium	100 °C (212 °F)
	Ambient	80 °C (176 °F)

Low pressure syphon tube/valve

Maximum design pressure	25 bar g (362 psi g)
Maximum design temperature	260 °C (500 °F)
Maximum working conditions	21 bar g @ 217 °C (304 psi g @ 422 °F)

High pressure syphon tube

Maximum design pressure	80 bar g (1160 psi g)
Maximum design temperature	450 °C (842 °F)
Maximum working conditions	60 bar g @ 450 °C (870 psi g @ 842 °F)

Overpressure limit table

Calibrated pressure range - bar (psi)		Overpressure P max - bar (psi)	
0-1.6 bar a, 0-2.5 bar a	(0-23.2 psi a) (0-36.25 psi a)	10	(145)
0-0.1 bar g	(0-1.45 psi g)	1	(14.5)
0-0.25 bar g	(0-3.6 psi g)	2	(29)
0-0.6 bar g	(0-8.7 psi g)	4	(87)
0-1 bar g	(0-14.5 psi g)	5	(72)
0-1.6 bar g,	(0-23.2 psi g)	10	(145)
0-2.5 bar g	(0-36 psi g)	10	(145)
0-4 bar g	(0-58 psi g)	17	(246)
0-6 bar g,	(0-87 psi g)	35	(507)
0-10 bar g	(0-145 psi g)	35	(507)
0-16 bar g,	(0-232 psi g)	80	(1160)
0-25 bar g	(0-362 psi g)	80	(1160)
0-40 bar g	(0-580 psi g)	120	(1740)
0-60 bar g	(0-870 psi g)	200	(2900)
0-100 bar g	(0-1450 psi g*)	320	(4640)
0-160 bar g	(0-2320 psi g*)	500	(7250)
0-250 bar g	(0-3626 psi g*)	800	(11600)

Note: High pressure 'spikes' above maximum overpressure, even of very short (milli-seconds) duration, could damage sensors. If pressure peaks are likely to occur in your application, we recommend the use of a pressure snubber. Alternatively, a higher range pressure transmitter could be used, though this would mean some loss of signal resolution.

Process connection

For fluids below 100 °C (212 °F) the EL2600 may be mounted directly via its 1/4" NPT connection.

Above 100 °C (212 °F), a 'U' syphon and isolating valve must be fitted between the EL2600 and the vessel or pipeline.

Technical data

Sensor type	0-1.6 bar a to 0-25 bar g (0-23 psi g to 0-230 psi g)	Piezoresistive
	0-40 bar g to 0-250 bar g (0-580 psi g to 0-5800 psi g)	Thin film
Supply voltage		10 Vdc to 30 Vdc
Accuracy		≤ 0.5%
Repeatability		≤ 0.05 of span
Hysteresis		≤ 0.1% of span
Protection rating		IP65

Approvals

EMC emissions	2004/108/EC, EN 61 326 Emission (Group 1, Class B)
EMC emissions	2004/108/EC, EN 61 326 Emission (Group 1, Class B) emissions and Immunity (industrial locations)

Materials

EL2600

Part	Material	
Body	Stainless steel	316L WS 1.4435
Connector	Moulded plastic	Polyamide PA 66

Low pressure syphon tube assembly (Valve ordered separately)

Part	Material	
Tube	Carbon steel	ASTM A 106 Gr. B. Phosphated
Valve	Body	Brass
	Handle	Phenolic

High pressure syphon tube assembly

Part	Material	
Tube	Carbon steel (zinc plated/passivated).	BS 3602: Part.1 1987 CFS 360
Valve	Body	Carbon steel
	Seat	PEEK/Polymain

Dimensions/weights (approximate) in mm (inches) and kg (lbs)

EL2600

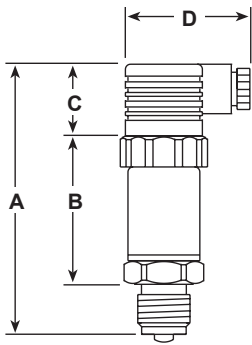

EL2600

A	B	C	D	Weight
104	57	28	48	0.2
(4.1)	(2.25)	(1.1)	(1.9)	(0.44)

'U' Syphon and isolating valve

E	F	G	H	J	K	Weight
160	50	150	160	60	150	0.5
(6.3)	(2)	(6)	(6.3)	(2.4)	(6)	(1.1)

Low pressure 'U' syphon

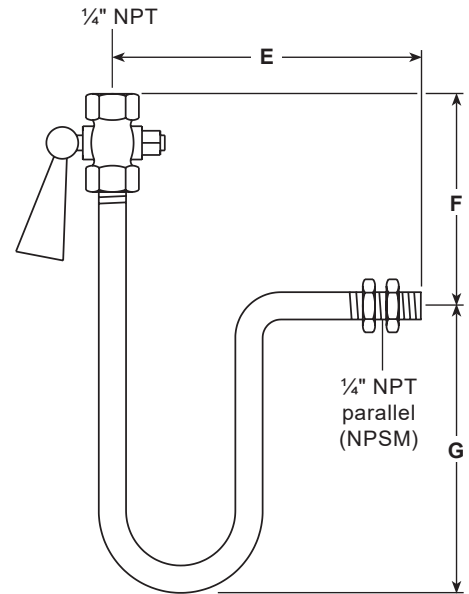

High pressure 'U' syphon

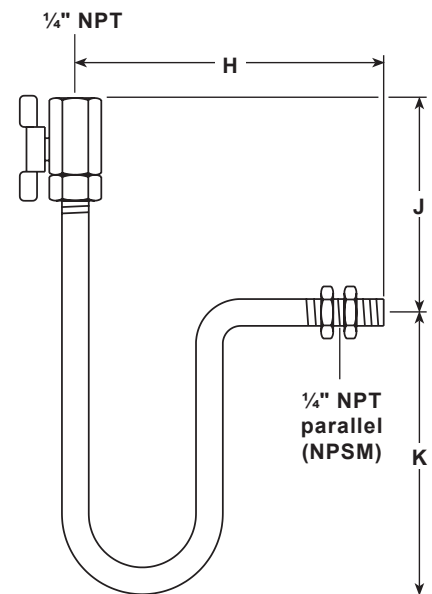

Safety information, installation and maintenance

This document does not contain sufficient information to install the product safely. See the Installation and Maintenance Instructions supplied with the product.

Safety

Your attention is drawn to Safety Information Leaflet IM-GCM-10.

Installation

It is essential to use a 'U' syphon and valve for temperatures above 100 °C (212 °F) to avoid damage to the unit.

Maintenance

No specific maintenance is required, but we recommend inspection and re-calibration of the transmitter once a year.

How to order

Example:

1 - Spirax Sarco EL2600 pressure transmitter, range 0 - 16 bar g (0 - 232 psi g), with low pressure 'U' syphon and isolating valve.