

## Direct Contact Desuperheaters

### Description

Spirax Sarco direct contact desuperheaters reduce the temperature of superheated steam to produce steam temperatures approaching saturation temperature. To cool the superheated steam, water is entrained and flashed into vapour by absorbing heat from the steam.

### Typical applications:

- To reduce the temperature of steam discharged from turbine by-pass systems on power plants for heat exchangers, dump stations etc.
- To improve heat transfer of indirect contact heat exchangers - shell and tube, plate type, reactor heating jackets etc.
- To reduce the temperature of steam on direct contact applications - food cooking kettles, in-line steam heaters, tobacco drying plant and paper mills.

Send us your requirements using our Desuperheater Enquiry Form available from our website.

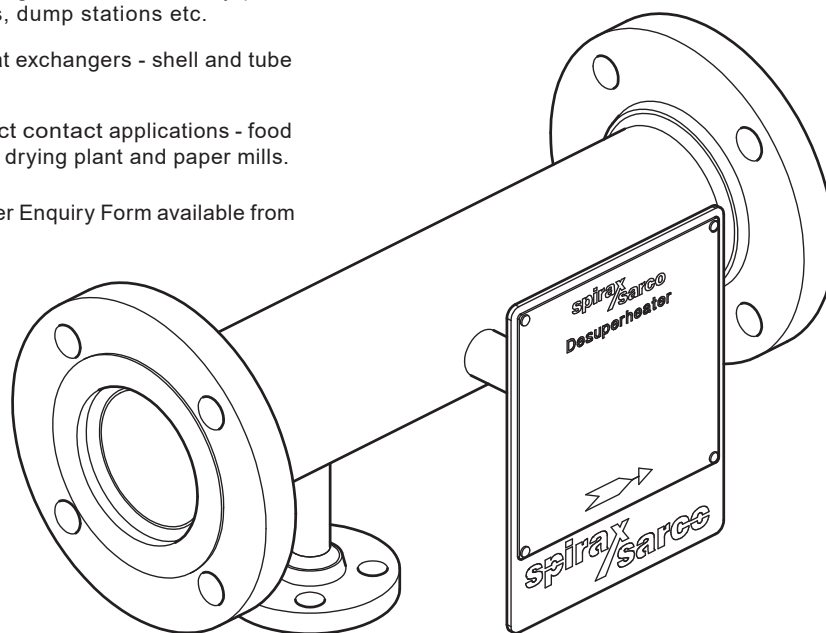

### Features:

- Low cost simple, robust design.
- No moving parts to wear.
- Minimal steam pressure drop.
- Flexible design options.

### Standards and approvals

Spirax Sarco desuperheaters are available built to ASME B 31.3 design code. Also available are ASME Division 1.

This product fully complies with the requirements of the Pressure Equipment Directive 2014/68/EU and carries the **CE** mark when so required.

Welding is in accordance with ASME IX.

Connections (EN 1092 or ASME B16.5) are sized to suit the process conditions.

Standard ASTM materials of construction include: Carbon steel, Stainless steel, Chrome molybdenum steel etc.,

### Certification (included as standard):

1. Desuperheater general arrangement drawing.
2. Installation, operation and maintenance instructions.
3. Hydrostatic test certificate.
4. Letter of conformity.

The following certificates / documents can be supplied at an additional cost.

5. Material certificates to EN 10204 3.1 with a corresponding material location diagram.
6. NDT reports.

## Pressure/temperature limits

Spirax Sarco desuperheaters are bespoke products, individually designed to meet user defined process conditions. Mechanical design pressure and mechanical design temperature limitations are stated on the desuperheater data sheet available from our online sizing software. These limits are also stated on the product nameplate. Pressure/temperature ratings for these products will be in accordance with ASME B16.5-1996 or EN 1092-1:2013 as appropriate.

## Available types

### Spray type desuperheaters

A simple type of in-line desuperheater with cooling water injected into the centre of the unit via an atomizing nozzle sprayed in the direction of the steam flow. **Spirax Sarco spray type desuperheaters are available in two options:-**

#### 1. Spray nozzle desuperheater (SND)

The assembly is designed for mounting on a suitable flanged branch on the steam pipework. A thermal sleeve installed downstream of the unit is recommended.

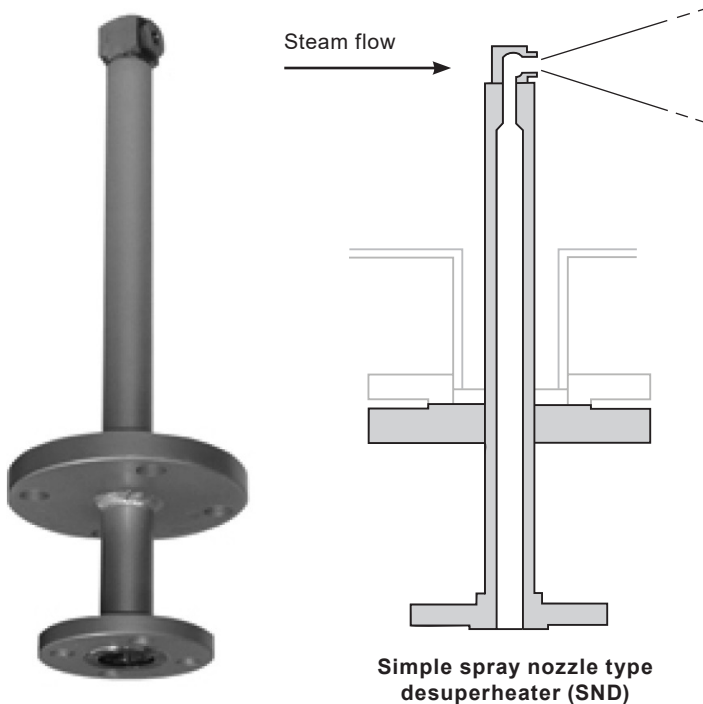

#### Applications:

- Relatively constant load handling duties.
- Retrofitting a desuperheater to an existing steam line (steam line and thermal sleeve by others).
- Large steam lines where an STD could be cost prohibitive.

#### Mechanical design temperature and flange rating

<371 °C (<700 °F)	ASME 150, ASME 300, ASME 600, ASME 900, ASME 1500 + PN16, PN25, PN40, PN63 and PN100 Slip-on
371 - 427 °C (700 - 800 °F)	ASME 150, ASME 300, ASME 600, ASME 900, ASME 1500 + PN16, PN25, PN40, PN63 and PN100 Weld neck
424 - 570 °C (795 - 1058 °F)	ASME 150, ASME 300, ASME 600, ASME 900, ASME 1500 Weld neck (Slip-on N/A)

#### Materials

Component	Mechanical design temperature up to and including 427 °C (800 °F)	Mechanical design temperature above 427 °C (800 °F) up to and including 570 °C (1058 °F)
Pipe	ASTM A106 Grade B	ASTM A335 P11
Flanges	ASTM A105N	ASTM A182 F11
Spray nozzle	ASTM A182 F316L	ASTM A182 F11
Nozzle holder	ASTM A350 LF2N	ASTM A182 F11

## 2. Spray type desuperheater (STD)

A complete Desuperheater ready for installation, including spray nozzle, nozzle housing, thermal sleeve and flanged shell.

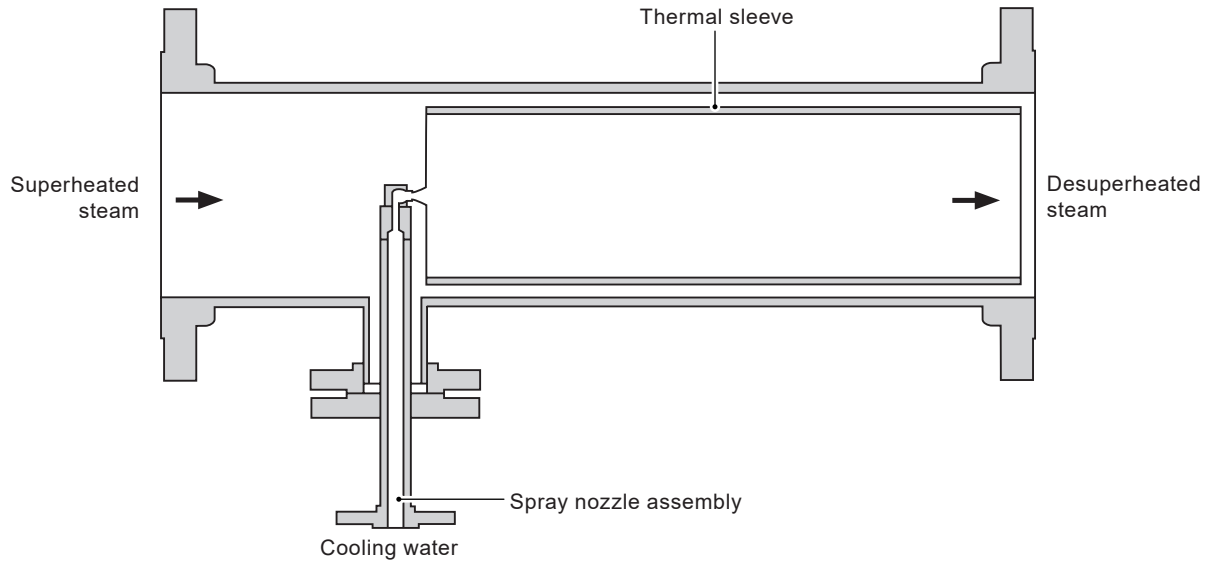

Standard STD has welded spray nozzle assembly. Item shown above is STD with removable spray nozzle.

### Applications:

- Relatively constant load handling duties.
- Dumping steam application.
- Control of downstream temperature not critical.

### Mechanical design temperature and flange rating

<371 °C (<700 °F)	ASME 150, ASME 300, ASME 600 + PN16, PN25, PN40 Slip-on (Weld neck optional)
371 - 427 °C (700 - 800 °F)	ASME 150, ASME 300, ASME 600 + PN16, PN25, PN40 Weld neck (Slip-on N/A)
424 - 570 °C (795 - 1058 °F)	ASME 150, ASME 300, ASME 600, ASME 900, ASME 1500 Weld neck (Slip-on N/A)

### Materials

Component	Mechanical design temperature up to and including 427 °C (800 °F)	Mechanical design temperature above 427 °C (800 °F) up to and including 570 °C (1058 °F)
Shell	ASTM A106 Grade B	ASTM A335 P11
Water branch	ASTM A106 Grade B	ASTM A335 P11
Flanges	ASTM A105N	ASTM A182 F11
Spray nozzle	ASTM A182 F316L	ASTM A182 F11
Nozzle holder	ASTM A350 LF2N	ASTM A182 F11
Thermal sleeve	ASTM A312 TP316L	ASTM A335 P11

## Venturi type desuperheaters (VTD)

The venturi principle is used to create regions of high velocity and turbulence which produces intimate contact between the steam and cooling water.

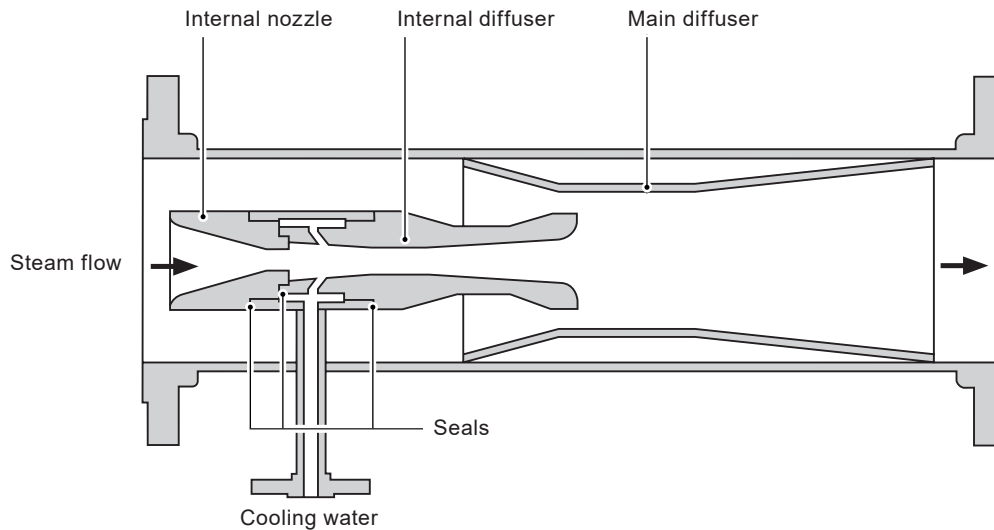

### Application

- Suitable for most general plant applications, except where high turndowns on cooling water are required.
- Flow turndowns between 3:1 and 10:1 depending on conditions.

### Mechanical design temperature and flange rating

<371 °C (<700 °F)	ASME 150, ASME 300, ASME 600 + PN16, PN25, PN40 Slip-on (Weld neck optional)
371 - 427 °C (700 - 800 °F)	ASME 150, ASME 300, ASME 600 + PN16, PN25, PN40 Weld neck (Slip-on N/A)
424 - 570 °C (795 - 1058 °F)	ASME 300, ASME 600, ASME 900, ASME 1500 + PN10, PN16, PN25, PN40, PN63 and PN100 Weld neck (Slip-on N/A)

### Materials

Component	Mechanical design temperature up to and including 427 °C (800 °F)	Mechanical design temperature above 427 °C (800 °F) up to and including 570 °C (1058 °F)
Shell	Sizes 1 to 2: ASTM A350 LF2N Size 3 and above: ASTM A106 Grade B	Sizes 1 to 2: ASTM A182 F11 Size 3 and above: ASTM A335 P11
Water branch	Sizes 1 to 2: ASTM A350 LF2N Size 3 and above: ASTM A106 Grade B	Sizes 1 to 2: ASTM A182 F11 Size 3 and above: ASTM A335 P11
Flanges	Sizes 1 to 2: ASTM A350 LF2N Size 3 and above: ASTM A105N	ASTM A182 F11
Nozzle	ASTM A182 F316L	ASTM A182 F11
Internal diffuser	Sizes 1 to 2: Not applicable Size 3 and above: ASTM A182 F316L	Sizes 1 to 2: Not applicable Size 3 and above: ASTM A182 F11
Internal housing	Sizes 1 to 2: Not applicable Size 3 and above: ASTM A350 LF2N	Sizes 1 to 2: Not applicable Size 3 and above: ASTM A182 F11
Main diffuser	Sizes 1 to 4: ASTM A350 LF2N Sizes 6 and 8: ASTM A240 / ASTM A312 316L Size 10: BS EN 10130:2006 DC01 Size 12 and above: ASTM A516 Gr70	Sizes 1 to 4: ASTM A182 F11 Sizes 6 and above: ASTM A387 Gr11
Internal seals	Soft copper	Soft copper

## Steam atomizing desuperheaters (SAD)

A high pressure auxiliary steam supply is used to atomize the incoming water within the diffuser of the unit.

The auxiliary steam pressure needs to be at least 1.5 times the desuperheater inlet pressure with a minimum pressure of 3 bar g.

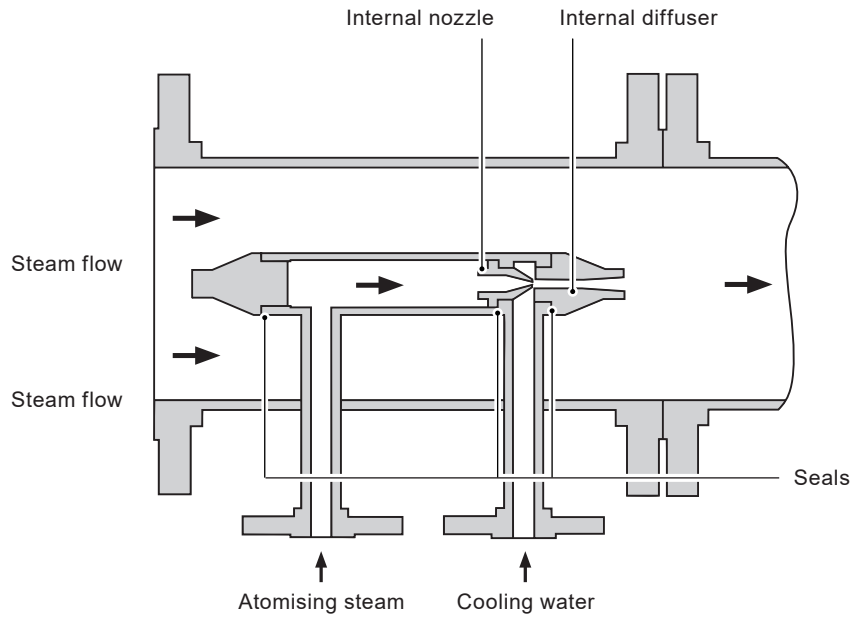

### Application

- High turndown applications where auxiliary steam is available, eg ;combined pressure reducing/desuperheating stations.

### Mechanical design temperature and flange rating

<371 °C (<700 °F)	ASME 150, ASME 300, ASME 600 + PN16, PN25, PN40 Slip-on (Weld neck optional)
374 - 525 °C (700 - 977 °F)	ASME 150, ASME 300, ASME 600 + PN16, PN25, PN40 Weld neck (Slip-on N/A)

### Materials

Component	Mechanical design temperature up to and including 427 °C (800 °F)	Mechanical design temperature above 427 °C (800 °F) up to and including 570 °C (1058 °F)
Shell	ASTM A106 Grade B	ASTM A335 P11
Atomising steam branch	ASTM A106 Grade B	ASTM A335 P11
Water branch	ASTM A106 Grade B	ASTM A335 P11
Flanges	ASTM A105N	ASTM A182 F11
Nozzle	ASTM A182 F316L	ASTM A182 F11
Diffuser	ASTM A182 F316L	ASTM A182 F11
Internal housing	ASTM A350 LF2N	ASTM A182 F11
Internal seals	Soft copper	Soft copper

## Sizing and selection

There are a number of factors which must be considered in determining the best type of desuperheater for each application. Such factors are:-

1. Residual superheat.
2. Turndown.
3. Accuracy of final temperature.
4. Available pressure drop.
5. Cooling water pressure.
6. Auxiliary higher pressure steam available for atomising.
7. Cost.

With so many factors, it is not an easy task to develop a decision tree to aid selection, but the charts below have been developed to assist engineers in desuperheater selection. Please read this first chart in conjunction with the note at the bottom of the page.

### Desuperheater selection chart

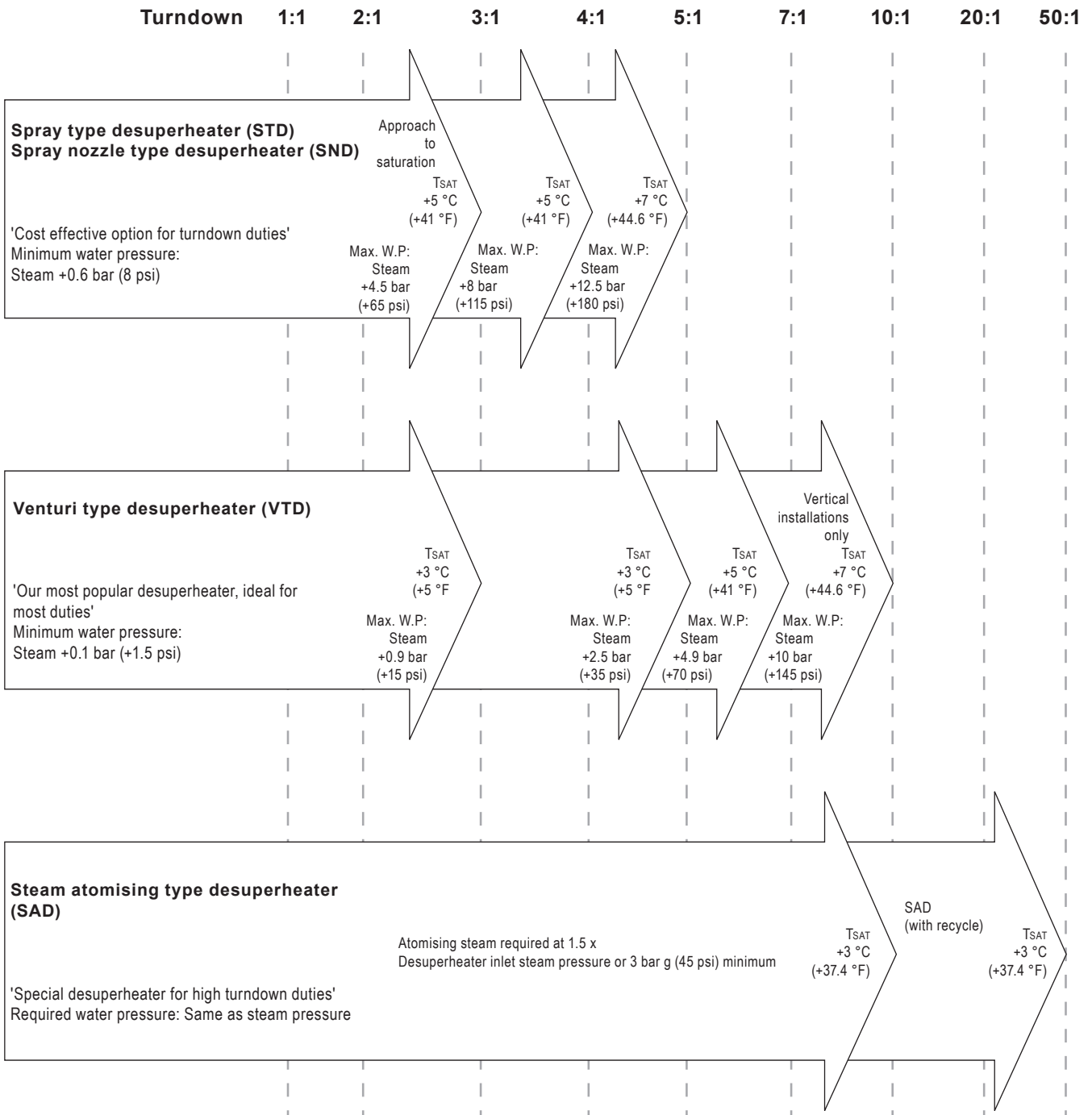

**Note:** For VTD's, turndowns above 7:1 must not be offered until design checks have been made by Spirax Sarco.

## Which desuperheater is right for my application?

This is a general guide and does not represent every option available.

Please contact us if you have any queries regarding selection for your specific application.

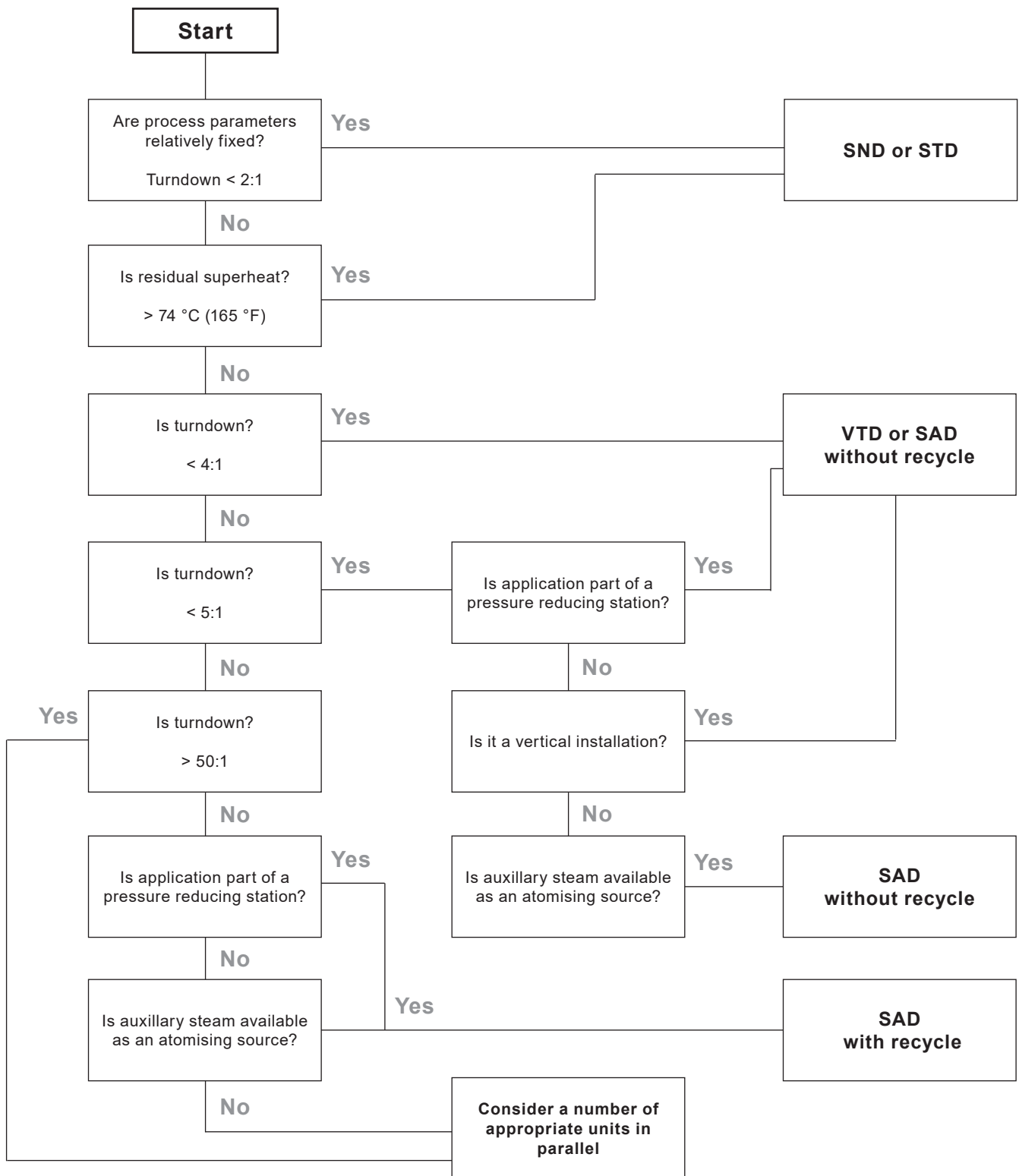

## Sizing and selection software

It is necessary to use our online sizing and selection software so that the desuperheater can be correctly specified and ordered. The software will generate a desuperheater data sheet and general assembly detail drawing of the resulting product. Please refer to TI-P475-06 'Desuperheater Online Programme Sizing Guidance' for further information.

## Safety information, installation and maintenance

For full details see the Installation and Maintenance Instruction that are supplied with the product.

### Installation note

Desuperheaters may be installed either horizontally or vertically with the steam flowing upwards. Spirax Sarco strongly advises against installations in which the steam flow is vertically downwards.

In the case of a horizontal installation the cooling water connection (and the atomising steam connection on a steam atomising desuperheater) should ideally point downwards, as this gives the best orientation for drainage of fluids in a shutdown situation. Other orientations are acceptable for satisfactory operation, but drainage is not as effective.

In a vertical installation we recommend that, the cooling water pipework (and atomising steam pipework, if applicable) should be brought to the Desuperheater from below the corresponding connections on the desuperheater. This will provide the best layout for drainage of fluids on shutdown.

## Desuperheating and pressure reducing stations

Spirax Sarco can provide complete desuperheating and pressure reducing stations including control valves, temperature sensors, pressure transmitters, instrumentation and pipework, all mounted on a support skid.

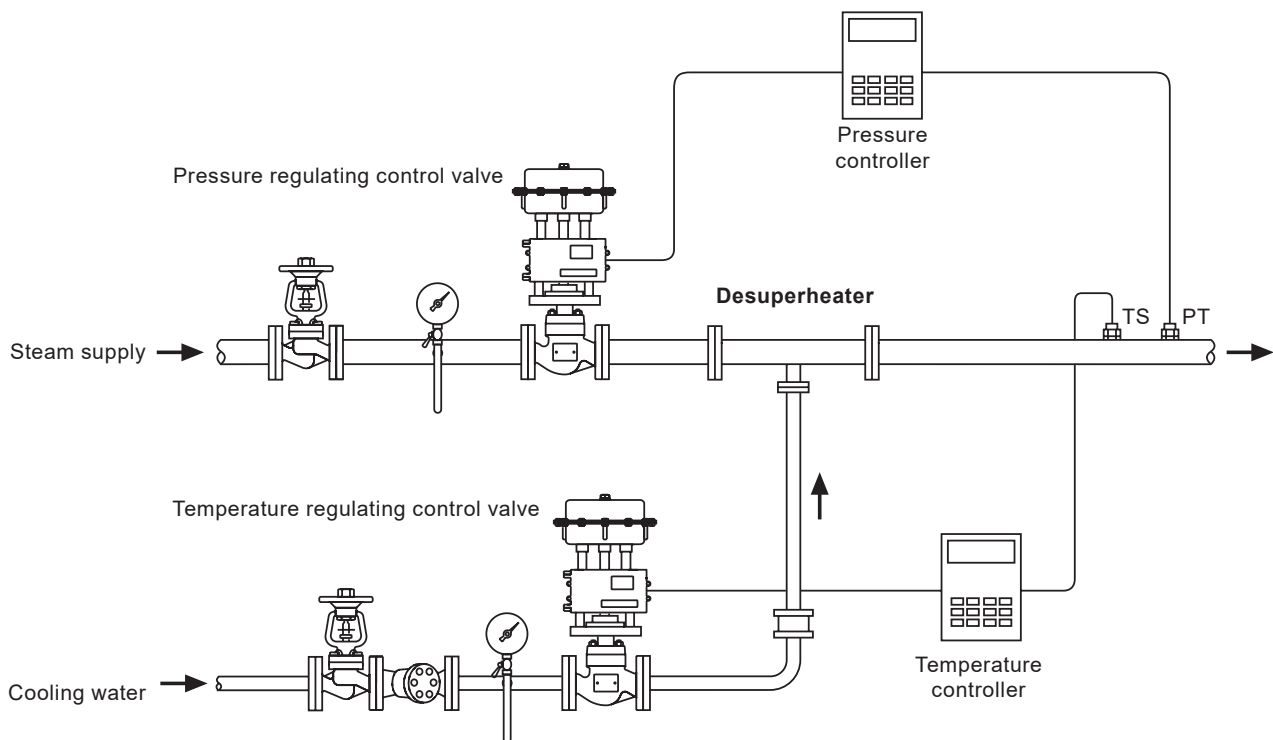

**Combined desuperheating and pressure reducing station for venturi and spray type desuperheaters**



## Sizes

Spirax Sarco desuperheaters are specified by their nominal inlet and outlet size in inches. For example an 80 mm (3.14") connection is referred to as Size 3, a 250 mm (9.84") would be Size 10.

## Dimensions and weights

Please refer to the general assembly detail drawing generated by the sizing and selection software for details of specific desuperheaters.

## Selection guide

		Example
<b>Desuperheater type</b>	STD, SND, VTD and SAD	<b>VTD</b>
<b>Steam inlet / outlet size, mm (inches)</b>	20 mm - 450 mm (0.78" - 17.7")	<b>080</b>
<b>Shell / pipe material</b>	CS - Carbon steel A106 Grade B. For VTD sizes 1 to 2, CS = A350 LF2N material CM - Chrome molybdenum A182 F11	<b>CS</b>
<b>Steam end connections</b>	ASME 150, ASME 300, ASME 600, ASME 900, ASME 1500 PN16, PN25, PN40, PN63 and PN100	<b>A600</b>
<b>Flange style</b>	Weld neck or slip-on	<b>WN</b>

## How to order

1 off Spirax Sarco Size 3 desuperheater model VTD080CS having ASME 600 RF weld neck flanged connections. (Attach the desuperheater Data Sheet with your order).

## Spare parts

For units with fixed internals, spare parts are not available.

Spare parts and internal diffuser removal tools are available for units fitted with removable internals.

For guidance ;

SAD of 6" and larger and VTD of 10" and larger are of a fully welded construction, hence spare parts are not available. There are no spares available for SND or STD with fixed nozzle assembly.

Please quote the equipment model number and serial number from the nameplate when requesting parts.