



Cert. No. LRQ 0963008

ISO 9001

## DH Type Flash Condensing Deaerator Heads

A simple low cost solution for deaerating boiler feedwater at atmospheric pressure

- Mixes hot and cold incoming flows
- Liberates oxygen and other gases
- Stainless steel for long maintenance free life
- Easy to install

### Description

Spirax Sarco flash condensing deaerator head is designed to mix incoming flows of cold make-up, condensate return and flash steam to the boiler feedtank. This mixing action is achieved by directing the downward flow through a baffle arrangement within the unit. This liberates dissolved gases from the cold make-up, which are vented to atmosphere. The cold make-up inlet is fitted with a spray screen which diffuses the flow, increasing its surface area to promote thorough mixing with the condensate and flash steam.

A Spirax Sarco flash condensing deaerator head consists of three parts:

- A mixing unit, which is bolted to the top of the tank and is supplied with connections to customer specification for cold make-up, condensate return, flash steam from blowdown etc.
- An immersion tube, which distributes the mixed fluids into the tank and has an integral plate flange which is sandwiched between the tank and mixing unit flanges. Immersion tubes are fully described in separate literature.
- Gaskets. Two gaskets are required, one fitted each side on the immersion tube flange. They are ordered separately.

### Available types

The mixing unit is available in five nominal diameters (DN150, DN200, DN250, DN300 and DN400) flanged to BS 4504 PN16 or BS 1560 Class 150.

Immersion tubes are available in diameters to suit the deaerator heads and lengths of 950, 1200, 1600 and 2100 mm to suit TM metric feedtanks. Since each deaerator head is built to suit specific plant requirements we recommend that your local Spirax Sarco Engineer is contacted for a connection layout sheet and to discuss your requirements.

### Selection table

Total steam generation rate (kg/h)	Mixing unit	Tank depth			
		1250	1500	2000	2500
5 000	DN150	MU150	MU150	MU150	MU150
		IT-950	IT-1200	IT-1600	IT-2100
10 000	DN200	MU200	MU200	MU200	MU200
		IT-950	IT-1200	IT-1600	IT-2100
20 000	DN250	MU250	MU250	MU250	MU250
		IT-950	IT-1200	IT-1600	IT-2100
30 000	DN300	MU300	MU300	MU300	MU300
		IT-950	IT-1200	IT-1600	IT-2100
50 000	DN400	MU400	MU400	MU400	MU400
		IT-950	IT-1200	IT-1600	IT-2100

### Limiting conditions

PN2.5 rating. Suitable for saturated steam 1 bar g, 120°C. The mixing unit only is hydraulically tested to 2 bar g.

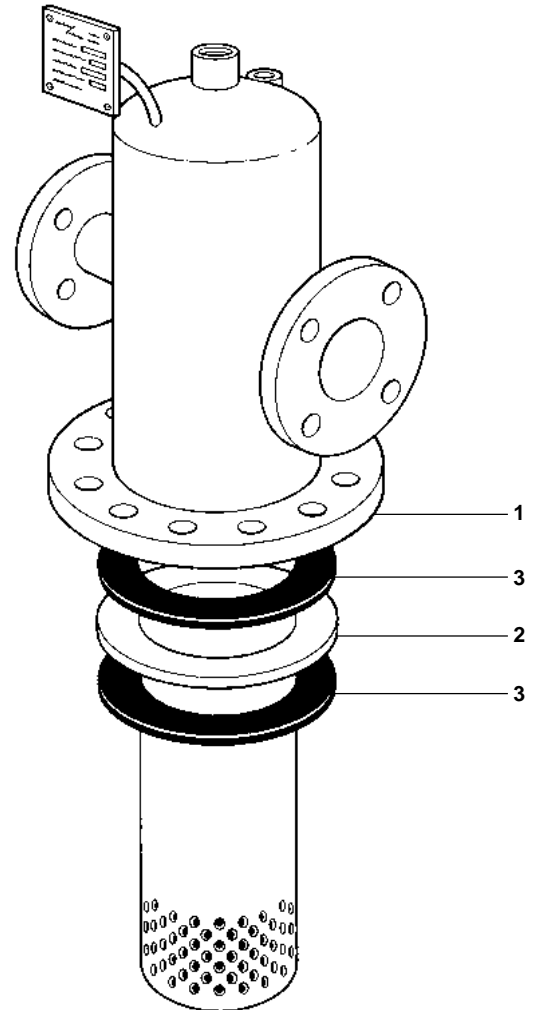

### Head comprises

Item	Quantity	Description	Material
1	1	Mixing unit	Austenitic stainless steel
2	1	Immersion tube	Austenitic stainless steel
3	2	Gasket	Silicone rubber

### Application

Spirax Sarco flash condensing deaerator heads are ideal for boiler feedtank applications. They are suitable for both new and retrofit applications. Each head is fitted with a connection for air vent and recirculating feedwater spray nozzle. The air vent is for the immediate venting of liberated gases (the connection should also include a vacuum breaker). For further details on the RFS recirculating feedwater spray systems see separate literature.

## Dimensions / weights (approximate) in mm and kg

### Mixing unit

Type	A	B	Weight
MU150_	175	484	30
MU200_	200	522	50
MU250_	220	557	65
MU300_	250	617	90
MU400_	290	680	125

For details of immersion tube and gaskets see separate literature.

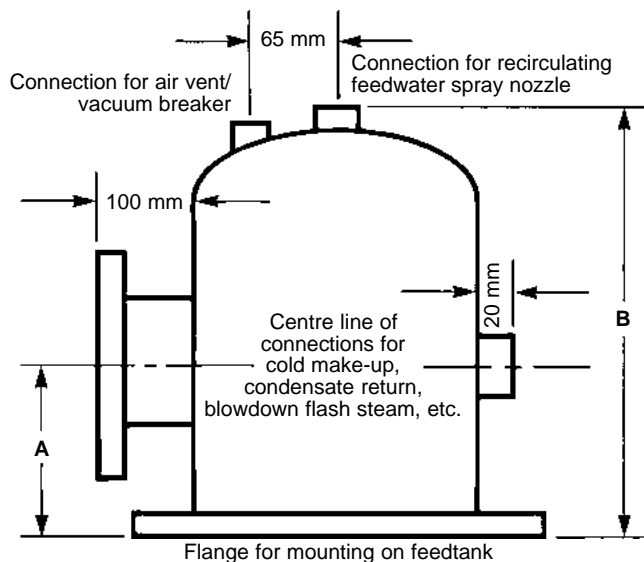

### How to specify

Atmospheric deaerator head in austenitic stainless steel consisting of mixing unit, immersion tube, and two gaskets. DN150, DN200, DN250, DN300 and DN400. Flanged BS 4504 PN16 / BS 1560 Class 300.

### How to order

To specify a 150 mm flash condensing deaerator head flanged BS 4504 PN16 (mixing unit plus immersion tube and gaskets to suit a 1250 mm deep feedtank):-

MU150 - PN16

IT150 - 950 PN16

2 off gaskets to suit IT150 - 1200 PN16

Connection details also need to be specified.