



DCV10 Stainless Steel and DCV10C Carbon Steel Centrally Guided Disc Check Valves

Description

The **DCV10** (cast stainless steel) and **DCV10C** (zinc plated cast carbon steel) are wafer pattern disc check valves that have been designed to be sandwiched between flanges for use with pumps and general cycling applications. They are suitable for use on a wide range of fluids for applications in process lines, hot water systems, steam and condensate systems etc. The centrally guided design ensures improved life span of the unit plus more reliability when compared to traditional disc check valves. These disc check valves will ensure correct flow of condensate and other suitable fluids whilst also preventing reverse flow - maintaining production and profit at all times.

Standards

Designed in accordance with BS EN 14341:2006.

This product fully complies with the requirements of the European Pressure Equipment Directive 2014/68/EU and carries the

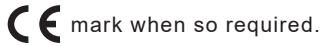

Shut-off

Shut-off conforms to EN 12266-1:2003 Rate F.

Certification

This product is available with certification to EN 10204 3.1.

Note: All certification/inspection requirements must be stated at the time of order placement.

DCV10

DN25 - DN100
(1" - 4")

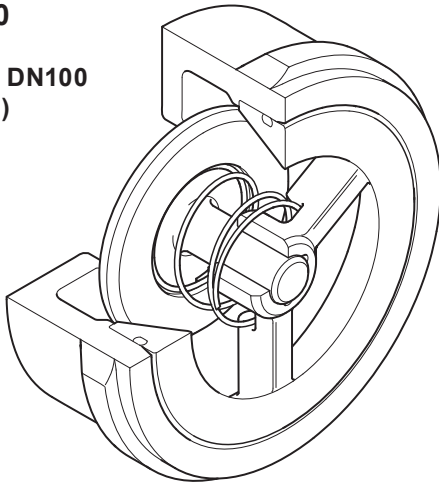

DCV10 and DCV10C

DN125 - DN250
(5" - 10")

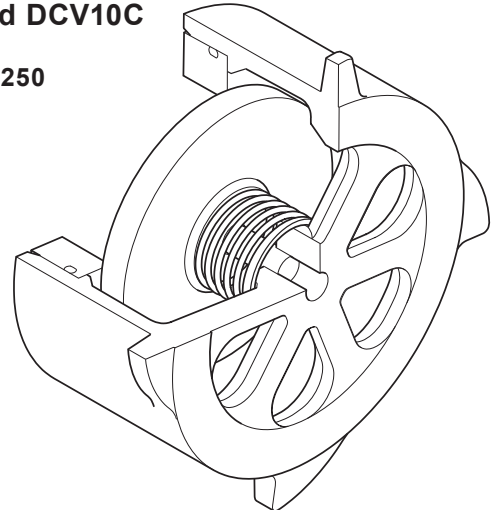

Sizes and pipe connections

Sizes DN25, DN32, DN40, DN50, DN65, DN80, DN100, DN125, DN150, DN200 and DN250
(1", 1½", 1¾", 2", 2¾", 3", 4", 5", 6", 8", and 10")

The PN rated design fits between the following flanges:	DN25 - DN100 (1" - 4")	EN 1092 PN25, PN16, PN40, JIS/KS 10K and JIS/KS 20K
	DN125 - DN250 (5" - 10")	EN 1092 PN25, PN16, PN40 and JIS/KS 20K

The ASME Class 300 design fits between the following flanges: ASME B 16.5 Class 150 and Class 300.

Face-to-face dimensions are in accordance with EN 558 Series 49 for the DN125 - DN200 (5" - 8") size range and EN 558 Series 52 for the DN250 (10").

Materials - DCV10 - DN25 - DN100 (1" - 4")

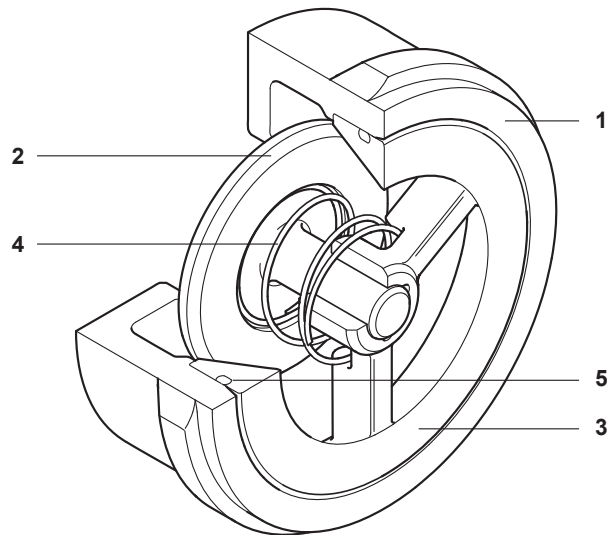

No.	Part		Material	
1	Body *	PN	Austenitic stainless steel	1.4308
		ASME	Austenitic stainless steel	A351 CF8
2	Disc		Austenitic stainless steel	A276 316L
			Austenitic stainless steel	AISI 316L
3	Spider		Martensitic stainless steel	BS 3146-2 ANC2
4	Spring		Stainless steel	BS 2056 316 S42
5	Gaskets		Reinforced exfoliated graphite	
* For DN32 and DN65 Material Austenitic stainless steel				1.4401 - 316L

Pressure/temperature limits

DCV10
DN25 - DN100 (1" - 4")

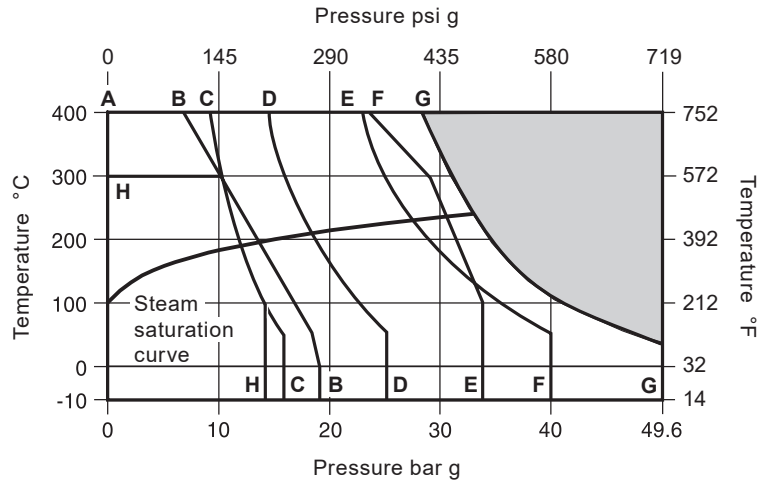

The product **must not** be used in this region.

- A - B** Flanged ASME Class 150.
- A - C** Flanged EN 1092 PN16.
- A - D** Flanged EN 1092 PN25.
- A - E** Flanged JIS/KS 20K.
- A - F** Flanged EN 1092 PN40.
- A - G** Flanged ASME Class 300.
- H - H** Flanged JIS/KS 10K.

Body design condition		PN40 or ASME Class 300	
PMA	Maximum allowable pressure	PN40	40 bar g @ 50 °C / 580 psi g @ 122 °F
		ASME Class 300	49.5 bar g @ 38 °C / 718 psi g @ 100 °F
TMA	Maximum allowable temperature	PN40	400 °C @ 23.8 bar g / 752 °F @ 345 psi g
		ASME Class 300	400 °C @ 28.4 bar g / 752 °F @ 412 psi g
Minimum allowable temperature		-10 °C	14 °F
PMO	Maximum operating pressure	PN40	40 bar g @ 50 °C / 580 psi g @ 122 °F
		ASME Class 300	49.5 bar g @ 38 °C / 718 psi g @ 100 °F
TMO	Maximum operating temperature	PN40	400 °C @ 23.8 bar g / 752 °F @ 345 psi g
		ASME Class 300	400 °C @ 28.4 bar g / 752 °F @ 412 psi g
Temperature limits		-10 °C to +400 °C	+14 °F to +752 °F
Minimum operating temperature		-10 °C	14 °F
Product is safe for use under full vacuum conditions			
	Designed for a maximum cold hydraulic test pressure of:	PN40	60 bar g / 870 psi g
		ASME Class 300	74.4 bar g / 1079 psi g

Materials - DCV10 and DCV10C - DN125 - DN250 (5" - 10")

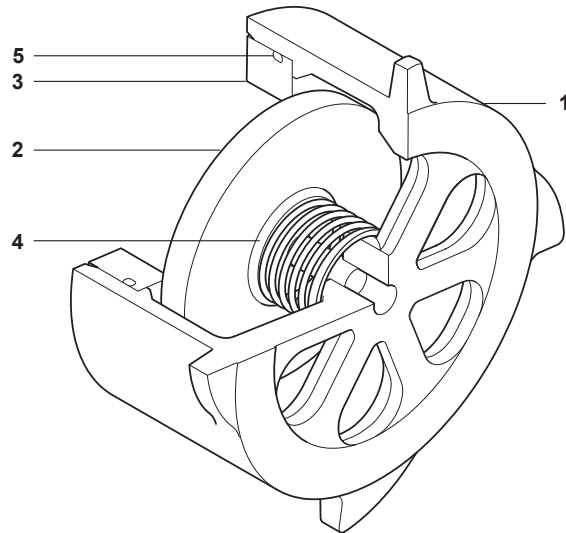

No.	Part		Material		
1	Body	DCV10	PN	Austenitic stainless steel	1.4308
			ASME	Austenitic stainless steel	A351 CF8
		DCV10C	PN	Carbon steel	1.0619+N
			ASME	Carbon steel	A216 WCB
2	Disc	PN	Austenitic stainless steel	1.4308	
		ASME	Austenitic stainless steel	A351 CF8	
3	Seat	PN	Austenitic stainless steel	1.4308	
		ASME	Austenitic stainless steel	A351 CF8	
4	Spring		Stainless steel	316L	
5	Gaskets		Reinforced exfoliated graphite		

Pressure/temperature limits

DCV10 DN125 - DN250 (5" - 10")

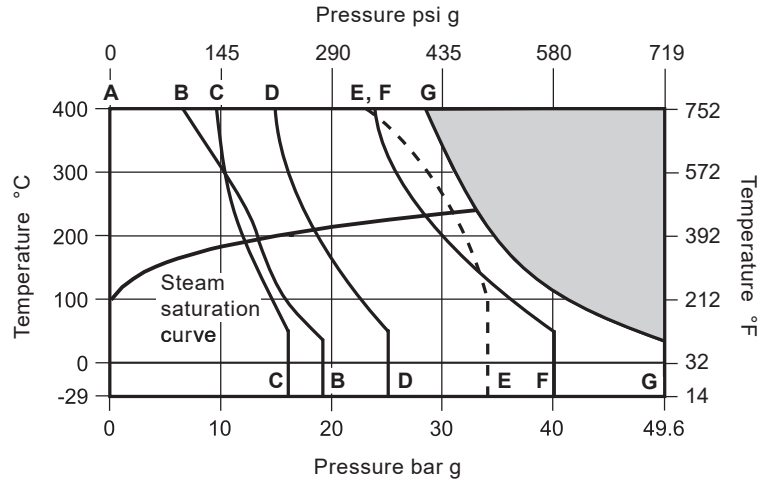

DCV10C DN125 - DN250 (5" - 10")

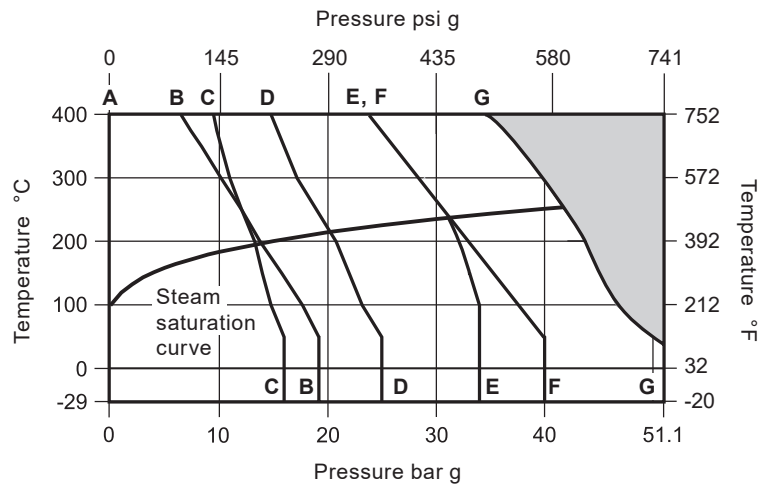

The product **must not** be used in this region.

- A - B** Flanged ASME Class 150.
- A - C** Flanged EN 1092 PN16.
- A - D** Flanged EN 1092 PN25.
- A - E** Flanged JIS/KS 20K.
- A - F** Flanged EN 1092 PN40.
- A - G** Flanged ASME Class 300.

Body design condition	PN40 or ASME Class 300	
PMA Maximum allowable pressure	DCV10	49.6 bar g @ 38 °C 719 psi g @ 100 °F
	DCV10C	51.1 bar g @ 38 °C 741 psi g @ 100 °F
TMA Maximum allowable temperature	DCV10	400 °C @ 28.4 bar g 752 °F @ 412 psi g
	DCV10C	400 °C @ 34.7 bar g 752 °F @ 503 psi g
Minimum allowable temperature	-29 °C -20.2 °F	
PMO Maximum operating pressure for saturated steam service	DCV10	33 bar g @ 241 °C 479 psi g @ 466 °F
	DCV10C	42 bar g @ 255 °C 609 psi g @ 491 °F
TMO Maximum operating temperature	DCV10	400 °C @ 28.4 bar g 752 °F @ 412 psi g
	DCV10C	400 °C @ 34.7 bar g 752 °F @ 503 psi g
Temperature limits	-29 °C to +400 °C -20.2 °F to +752 °F	
Minimum operating temperature	-29 °C -20.2 °F	
Product is safe for use under full vacuum conditions		
Designed for a maximum cold hydraulic test pressure of:	77 bar g	1117 psi g

Kv values

Size	DN25	DN32	DN40	DN50	DN65	DN80	DN100	DN125	DN150	DN200	DN250
	1"	1¼"	1½"	2"	2½"	3"	4"	5"	6"	8"	10"
Kv	10.8	10.8	26	43	43	80	130	188	213	432	735

For conversion:

Cv (UK) = Kv x 0.963

Cv (US) = Kv x 1.156

Opening pressures

Differential pressures with zero flow.

→ Flow direction

Size	DN25	DN32	DN40	DN50	DN65	DN80	DN100	DN125	DN150	DN200	DN250	
	1"	1¼"	1½"	2"	2½"	3"	4"	5"	6"	8"	10"	
↑	mbar	25	25	28	29	29	31	33	44	46	48.5	54
	mpsi	0.363	0.363	0.406	0.421	0.421	0.450	0.479	0.638	0.667	0.703	0.783
→	mbar	22.5	22.5	24.5	24.5	24.5	25.5	27	32	33	34	37
	mpsi	0.326	0.326	0.355	0.355	0.355	0.370	0.392	0.464	0.479	0.493	0.537
↓	mbar	20	20	20	20	20	30	20	20	20	20	20
	mpsi	0.290	0.290	0.290	0.290	0.290	0.435	0.290	0.290	0.290	0.290	0.290

Principle of operation

The DCV10 and DCV10C are opened by the pressure and flow of condensate and are closed by the pressure of the spring when the flow ceases and before reverse flow occurs.

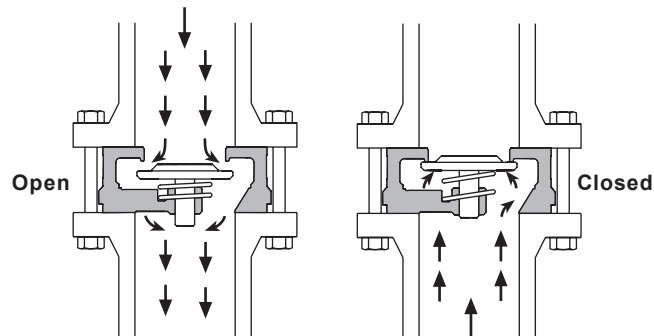

Pressure loss diagram

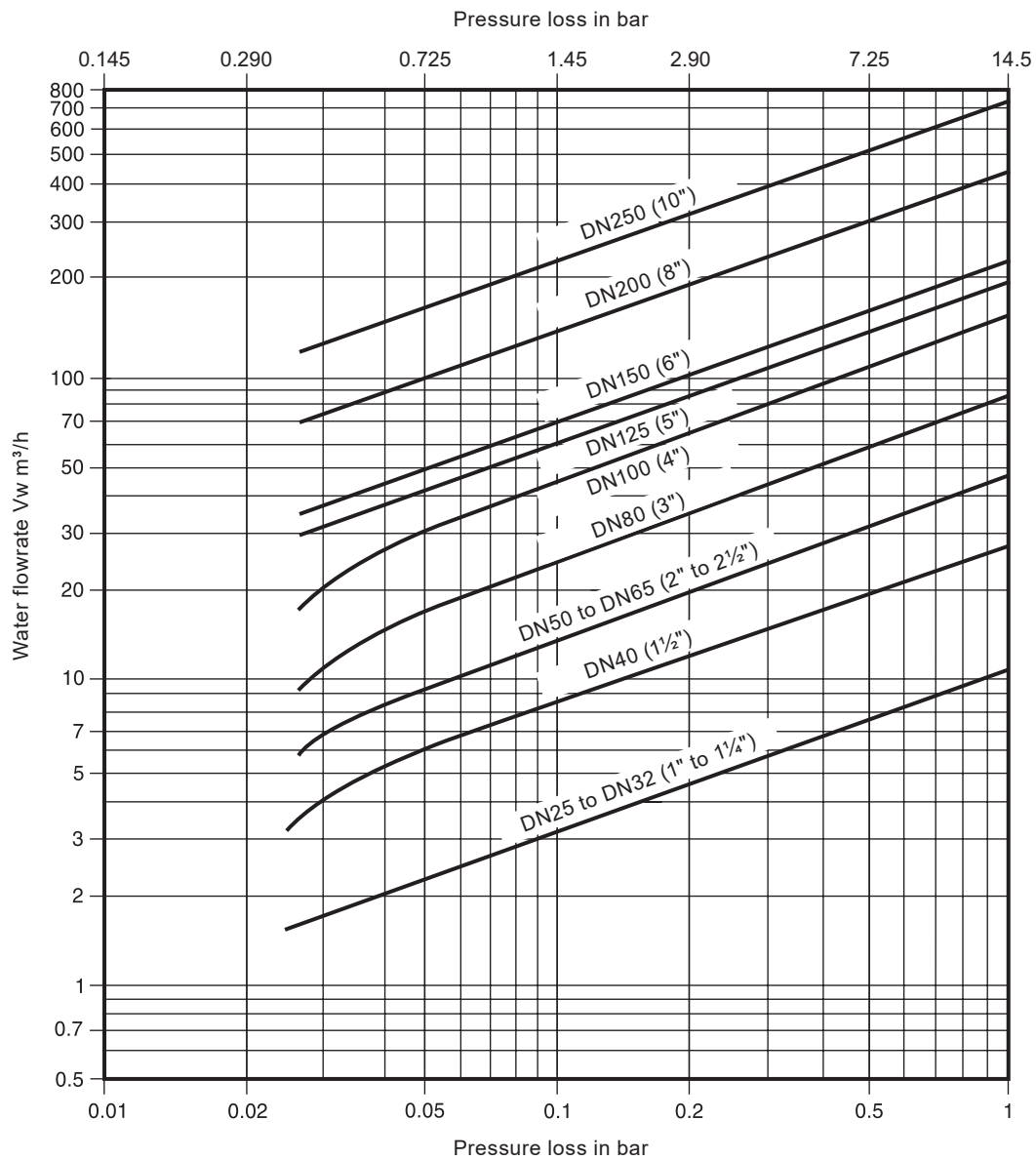

Pressure loss diagram with open valve at 20 °C (68 °F). The values indicated are applicable with horizontal flow. With vertical flow, insignificant deviations occur only within the range of partial opening.

The curves given in the chart are valid for water at 20 °C (68 °F). To determine the pressure for other fluids the equivalent water volume flowrate must be calculated and used in the graph.

$$\dot{V}_w = \sqrt{\frac{\rho}{1000}} \times \dot{V}$$

Where: \dot{V}_w = Equivalent water volume flow in l/s or m³/h

ρ = Density of fluid kg/m³

\dot{V} = Volume of fluid l/s or m³/h

Dimensions/weights (approximate) in mm (inches) and kg (lbs)

**DN25 - DN100
(1" - 4")**

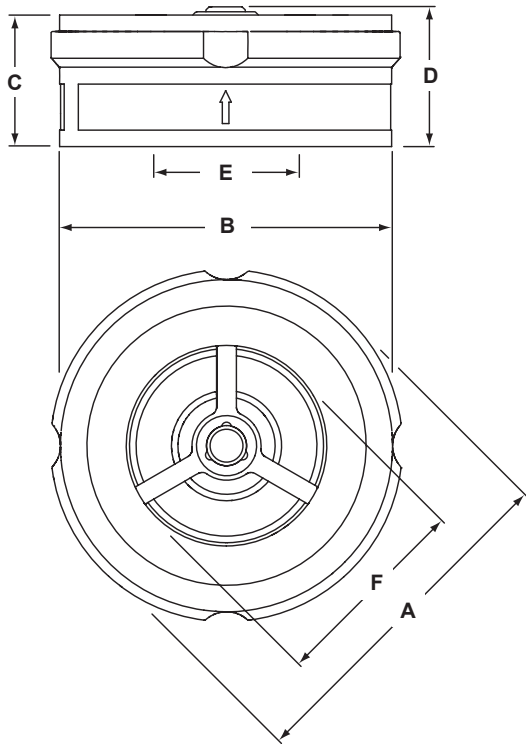

**DN125 - DN250
(5" - 10")**

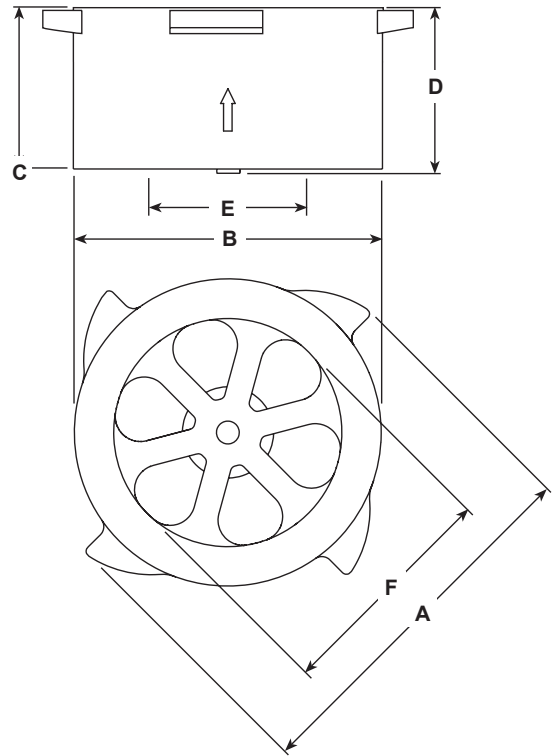

Size	A		B		C		D				E		F			
							Open		Closed							
	mm	inches	mm	inches	mm	inches	mm	inches	mm	inches	mm	inches	mm	inches		
PN40, PN25 and PN16	DN25	1"	71	2.80	71	2.80	22	0.87	31	1.22	24	0.94	25	0.98	34	1.34
	DN32	1¼"	75	2.95	75	2.95	28	1.10	37	1.46	30	1.18	32	1.26	34	1.34
	DN40	1½"	92	3.62	86	3.39	31.5	1.24	44	1.73	34	1.34	40	1.57	49	1.93
	DN50	2"	107	4.21	101	3.98	40	1.57	55	2.17	42.5	1.67	50	1.97	61	2.40
	DN65	2½"	115	4.53	115	4.53	46	1.81	61	2.40	48.5	1.91	65	2.56	61	2.40
	DN80	3"	142	5.59	131	5.16	50	1.97	69	2.72	53	2.09	80	3.15	89	3.50
	DN100	4"	178	7.01	162	6.38	60	2.36	81	3.19	60	2.36	100	3.94	100	3.94
	DN125	5"	219	8.62	188	7.40	90	3.54			91	3.58	117	4.61	125	4.92
	DN150	6"	253	9.96	214	8.43	106	4.17			106	4.17	146	5.75	150	5.91
	DN200	8"	325	12.8	269	10.6	140	5.51			142.3	5.60	183	7.20	200	7.88
DN250	10"	376.5	14.8	322	12.7	200	7.87			204	8.03	230	9.06	250	9.84	
JIS/KS 10K	DN25	1"	71	2.80	71	2.80	22	0.87	31	1.22	24	0.94	25	0.98	34	1.34
	DN32	1¼"	75	2.95	75	2.95	28	1.10	37	1.46	30	1.18	32	1.26	34	1.34
	DN40	1½"	92	3.62	86	3.39	31.5	1.24	44	1.73	34	1.34	40	1.57	49	1.93
	DN50	2"	107	4.21	101	3.98	40	1.57	55	2.17	42.5	1.67	50	1.97	61	2.40
	DN65	2½"	115	4.53	115	4.53	46	1.81	61	2.40	48.5	1.91	65	2.56	61	2.40
	DN80	3"	142	5.59	131	5.16	50	1.97	69	2.72	53	2.09	80	3.15	89	3.50

Dimensions/weights (approximate) in mm (inches) and kg (lbs)

**DN25 - DN100
(1" - 4")**

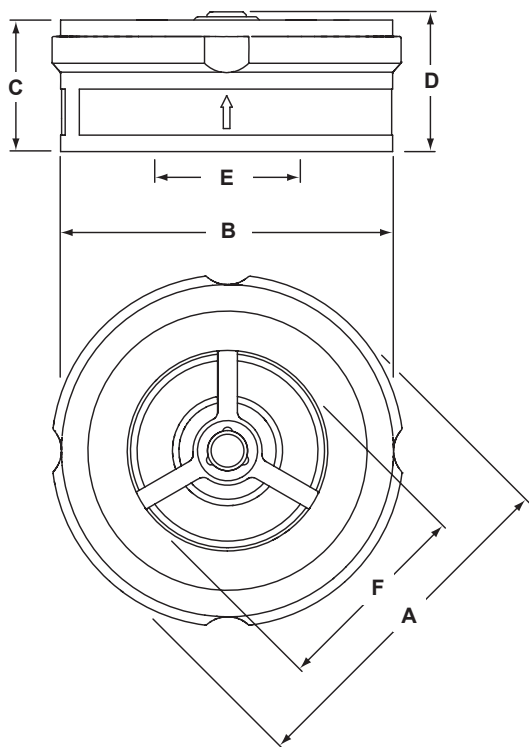

**DN125 - DN250
(5" - 10")**

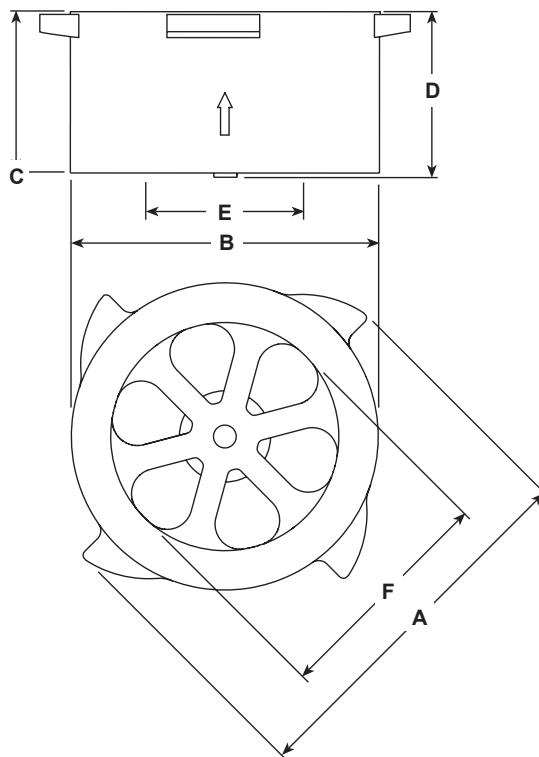

Size	A		B		C		D		E		F					
							Open	Closed								
	mm	inches	mm	inches	mm	inches	mm	inches	mm	inches	mm	inches				
JIS/KS 20K	DN100	4"	71	2.80	71	2.80	22	0.87	31	1.22	24	0.94	25	0.98	34	1.34
	DN125	5"	219	8.62	188	7.40	90	3.54			91	3.58	117	4.61	125	4.92
	DN150	6"	253	9.96	214	8.43	106	4.17			106	4.17	146	5.75	150	5.91
	DN200	8"	325	12.8	269	10.6	140	5.51			142.3	5.60	183	7.20	200	7.88
	DN250	10"	376.5	14.8	322	12.7	200	7.87			204	8.03	230	9.06	250	9.84
ASME Class 150 and ASME Class 300	DN25	1"	70	2.76	63	2.48	35.5	1.40	37.0	1.46	35	1.38	25	0.98	30	1.18
	DN40	1½"	95	3.74	85.5	3.37	45	1.77	47.0	1.85	45	1.77	40	1.57	48	1.89
	DN50	2"	108	4.25	101.5	4.00	56	2.20	57.5	2.26	56	2.20	50	1.97	61	2.40
	DN80	3"	146	5.75	133	5.24	71	2.80	71.0	2.80	71	2.80	80	3.15	89	3.50
	DN100	4"	178	7.01	162	6.38	60	2.36	81	3.19	60	2.36	100	3.94	100	3.94
	DN125	5"	219	8.62	188	7.40	90	3.54			91	3.58	117	4.61	125	4.92
	DN150	6"	253	9.96	214	8.43	106	4.17			106	4.17	146	5.75	150	5.91
	DN200	8"	325	12.8	269	10.6	140	5.51			142.3	5.60	183	7.20	200	7.88
DN250	10"	376.5	14.8	322	12.7	200	7.87			204	8.03	230	9.06	250	9.84	

Weights are shown on the next page

Weights (approximate) in kg (lbs)

	Size	Weight	
		kg	lbs
PN40, PN25 and PN16	DN25 1"	0.40	0.88
	DN32 1¼"	0.7	1.54
	DN40 1½"	0.82	1.81
	DN50 2"	1.34	2.92
	DN65 2½"	2.34	5.16
	DN80 3"	2.56	5.64
	DN100 4"	5.30	11.7
	DN125 5"	11.00	24.3
	DN150 6"	16.00	35.3
	DN200 8"	32.00	70.5
	DN250 10"	60.00	132
JIS/KS 10K	DN25 1"	0.40	0.88
	DN32 1¼"	0.7	1.54
	DN40 1½"	0.82	1.81
	DN50 2"	1.34	2.92
	DN65 2½"	2.34	5.16
	DN80 3"	2.56	5.64

	Size	Weight	
		kg	lbs
JIS/KS 20K	DN100 4"	0.40	0.88
	DN125 5"	11.00	24.3
	DN150 6"	16.00	35.3
	DN200 8"	32.00	70.5
	DN250 10"	60.00	132
	ASME Class 150 and ASME Class 300	DN25 1"	0.50
DN40 1½"		0.82	1.81
DN50 2"		1.85	4.08
DN80 3"		3.50	7.72
DN100 4"		5.30	11.7
DN125 5"		11.00	24.3
DN150 6"		16.00	35.3
DN200 8"		32.00	70.5
DN250 10"		60.00	132

Safety information, installation and maintenance

For full details see the Installation and Maintenance Instructions (IM-P601-33) supplied with the product.

Installation note:

The DCV10 and DCV10C can be fitted in either a horizontal or vertical line in accordance with the direction of flow arrow on the body.
Note: Flanges, bolts (or studs), nuts and gaskets are to be supplied by the installer.

Disposal:

These products are recyclable. No ecological hazard is anticipated with the disposal of these products providing due care is taken.

How to order

Example: 1 off Spirax Sarco DN80 DCV10 stainless steel check valve to fit between PN16 flanges.

Spare parts

The DCV10 and DCV10C are non-maintainable disc check valves - There are no available spares.