

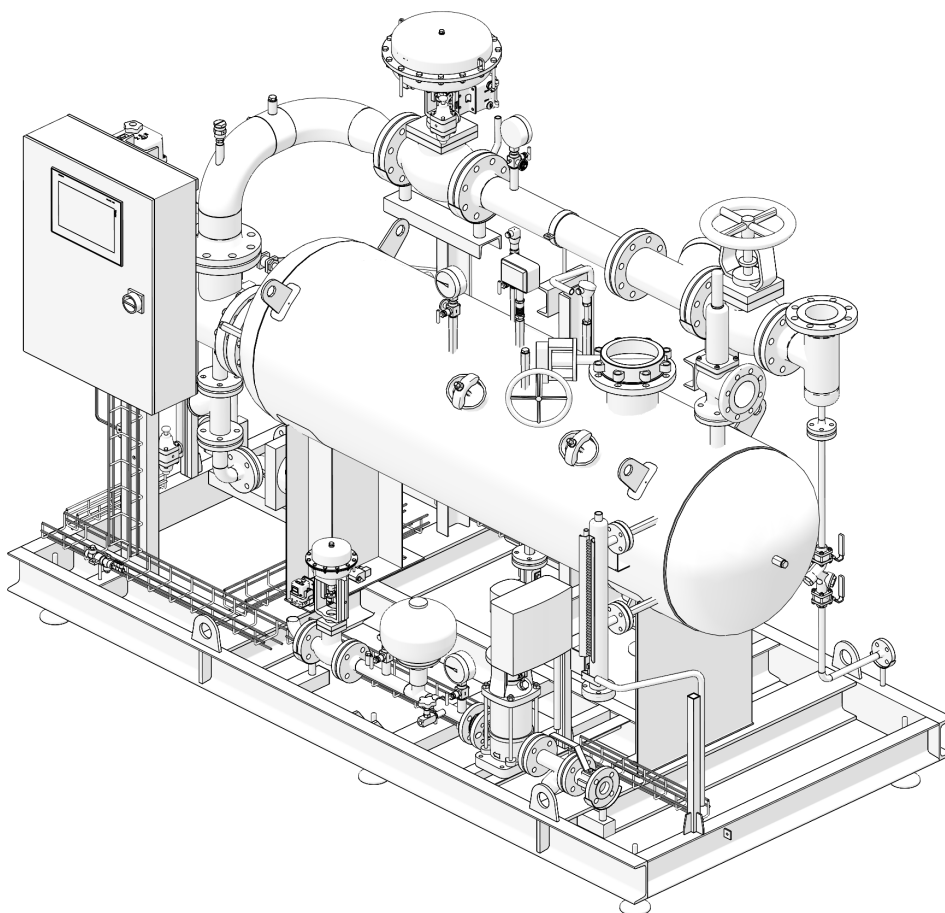

CSG-FB

Clean steam generation system for Food & Beverage



Description

Spirax Sarco has created a new range of steam generators for food and beverage applications to deliver food quality steam, specifically for direct injection processes within the food & beverage industry sector, where steam is considered as an ingredient. Primary heating medium is plant steam and the secondary steam should be generated from either de-mineralised or reverse osmosis quality water. All generators are supplied as packaged solutions ready to install and commission.

Designed, manufactured and approved for Steam and Condensate applications. This product complies with EC1935:2004 Food Contact Materials. It also complies with regulation EC2023:2006 on good manufacturing practice for materials and articles intended to come into contact with food.

Product range

Size:	CSG-FB-020 nominal production capacity 200 kg/h (440 lbs/hr)*	(*) max steam production at reference operating conditions: primary steam at 10 bar g (145 psi g), production at 5 bar g (73 psi g), feed water at 20 °C (68 °F).
	CSG-FB-050 nominal production capacity 500 kg/h (1002 lbs/hr)*	
	CSG-FB-110 nominal production capacity 1100 kg/h (2425 lbs/hr)*	
	CSG-FB-160 nominal production capacity 1600 kg/h (3527 lbs/hr)*	

Versions/Applications: **FB** Food and Beverage steam injection

Construction and main features

- System complete, functional and safe
- Compact design
- Modulating pressure and level control: pressure stability and steam quality improvement
- Intelligent PLC with SIMS technology, easy maintenance
- Packaged system with on board wired control panel: easy installation
- Automated start up/commissioning sequence
- Configurable options to suit individual needs
- System diagnostics
- Preventive maintenance
- Pre-heater can reduce plant steam usage by a minimum of 8% at peak flow
- Spirax Sarco's worldwide service

Compliances available **but not standard** in all geographies

	EMEA		Americas		Asia Pacific	
	STD	On request	STD	On request	STD	On request
-  mark with EU declaration of conformity according to the following directives:	●					●
- 2014/68/EU (PED)	●					●
- 2014/35/EU (LVD)	●					●
- 2014/30/EU (EMC)	●					●
- EC1935/2004 requirements as products intended to come into contact with food.	●					
- ASME design with U stamp certification			●			
- Chinese GB national standard					●	
- GB4806 requirements as products intended to come into contact with food.						●
- Seismic compliance		●		●		●

Design conditions

Primary side	Design pressure	12.8 bar g	(187 psi g)	For a bespoke design, contact Spirax Sarco	
	Design temperature	194.4 °C	(382 °F)		
Secondary side	Design pressure	8 bar g	(116 psi g)		
	Design temperature	194.4 °C	(382 °F)		
	Safety valve set pressure	7 bar g	(101.5 psi g)		
Feedwater	Design pressure	8 bar g	(116 psi g)		
	Design temperature	without pump	110 °C		(230 °F)
		with pump	100 °C		(212 °F)

Maximum operating conditions

	Without pump	With pump	
Production	Clean saturated steam, up to 6 bar g/165.0 °C (Clean saturated steam, up to 97 psi g/206 °F)		
Primary side	Plant steam, up to 12 bar g/191.7 °C (Plant steam, up to 174 psi g/345 °F)		
Feedwater	$P_{min.} \geq (P_{clean\ steam} * 1.1) + 0.5\ bar\ g$ $(P_{min.} \geq (P_{clean\ steam} * 1.1) + 7.2\ psi\ g)$ Note, If pre-heater option selected, up to an additional 0.5 bar (7.2 psi) of feedwater pressure may be needed in excess of the calculation above depending upon system size and process conditions.	Net positive suction head required (see IM)	Minimum ambient temperature: 0 °C Designed for indoor installation only, protect from freezing.
	$P_{target.} \geq (P_{clean\ steam} * 1.1) + 1\ bar\ g\ *$ $(P_{target.} \geq (P_{clean\ steam} * 1.1) + 7.2\ psi\ g)$ *This pressure may need to be varied on commissioning, see IM. Note, If pre-heater option selected, up to an additional 0.5 bar (7.2 psi) of feedwater pressure may be needed in excess of the calculation above depending upon system size and process conditions.		

Note: Feedwater is recommended to be demineralised or Reverse Osmosis quality to ensure high performance.

Utilities

	Unit without pump	Unit with pump
Electrical supply (cabinets)	1 x 90-132 V AC or 1 x 180-264 V AC 50/60 Hz 0.4 kW (inst.)	3 x 200-460 V AC* 50/60 Hz 1 kW (sizes 020-050) (inst.) 1.5 kW (size 110) (inst.) 2 kW (size 160) (inst.)
Air supply (filters)	Minimum 5 bar g (72.5 psi g) to maximum 7 bar g (101.5 psi g) (only for the unit with pneumatic actuators or Integrity test option)	

***Note:** A single leg is taken from the three phase supply to power the PSU, ensure the single leg will have a voltage in the range required for single phase.

Performance of the units

Max clean steam production (kg/h), with feedwater at 20 °C:	Clean steam pressure/bar g			Max clean steam production (lbs/hr), with feedwater at 68 °F:	Clean steam pressure/psi g			
	4.5	4.0	3.5		65.3	58.0	50.8	
CSG-FB-020	10.0	225	259	297	145.0	496	570	654
	9.5	205	239	276	137.8	452	526	609
	9.0	185	219	255	130.5	407	482	562
	8.5	164	197	236	123.3	361	435	515
	8.0	142	175	212	116.0	314	387	467
CSG-FB-050	10.0	588	682	783	145.0	1296	1,503	1,747
	9.5	536	625	732	137.8	1181	1,379	1,613
	9.0	485	571	671	130.5	1069	1,259	1,479
	8.5	431	516	611	123.3	951	1,138	1,347
	8.0	375	461	553	116.0	826	1,017	1,219
CSG-FB-110	10.0	1,302	1,526	1,637	145.0	2,871	3,363	3,599
	9.5	1,181	1,395	1,500	137.8	2,603	3,074	3,307
	9.0	1,054	1,264	1,500	130.5	2,324	2,786	3,307
	8.5	940	1,136	1,360	123.3	2,073	2,503	2,999
	8.0	833	1,006	1,223	116.0	1,836	2,217	2,695
CSG-FB-160	10.0	1,894	2,220	2,552	145.0	4,175	4,894	5,625
	9.5	1,702	2,026	2,371	137.8	3,753	4,467	5,228
	9.0	1,511	1,828	2,172	130.5	3,331	4,031	4,789
	8.5	1,323	1,629	1,969	123.3	2,916	3,581	4,341
	8.0	1,144	1,427	1,760	116.0	2,522	3,146	3,880

Clean steam pressure shown 3.5 bar g - 4.5 bar g (50.8 psi g - 65.3 psi g) illustrative only, full clean steam pressure range is 1 to 6 bar g (14.5 - 97 psi g).

Contact your Spirax Sarco representative for correct performance.

Dimensions and weights with pre-heater option
 approximate in mm (inches) and kg (lbs) of a standard unit

	Dimensions mm (inches)				Weights kg (lbs)		
	L Length	W Width	H Height	E Clearance for tube bundle extraction	Empty	In operation	Maximum
CSG-FB 020	2000 (79)	850 (33)	1840 (72)	1250 (49)	600 (1323)	670 (1477)	850 (1874)
CSG-FB 050	2350 (93)	850 (33)	1840 (72)	1300 (51)	870 (1918)	1070 (2359)	1270 (2799)
CSG-FB 110	2450 (96)	1450 (57)	2060 (81)	1600 (63)	1100 (2425)	1450 (3197)	1700 (3748)
CSG-FB 160	2950 (116)	1450 (57)	2060 (81)	2000 (78)	1550 (3417)	2050 (4519)	2450 (5401)

For detailed dimensions of the unit, size and position of the connections, clearance for the tube bundle extraction, weights and other constructive information, refer to the specific general arrangement drawing of the product.

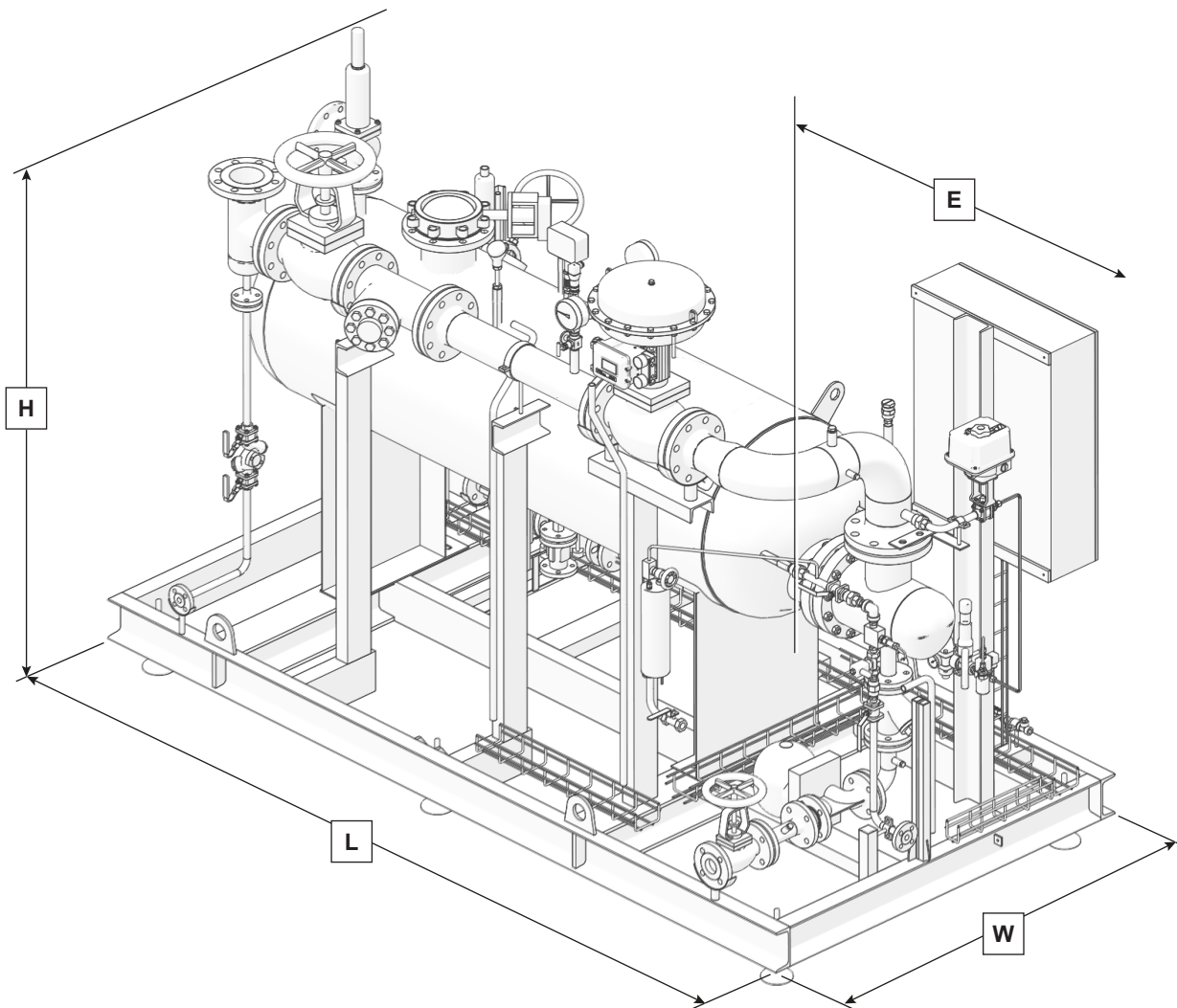

Dimensions and weights of the units with EnEV option - insulation 100 mm
 approximate in mm (inches) and kg (lbs)

	Dimensions mm (inches)				Weights kg (lbs)		
	L Length	W Width	H Height	E Clearance for tube bundle extraction	Empty	In operation	Maximum
CSG-FB 020	2100 (83)	950 (37)	1950 (77)	1250 (49)	700 (1543)	800 (1764)	950 (2094)
CSG-FB 050	2500 (98)	1100 (43)	2000 (79)	1300 (51)	1000 (2205)	1200 (2646)	1400 (3086)
CSG-FB 110	2550 (100)	1450 (57)	2250 (89)	1600 (63)	1300 (2866)	1600 (3527)	1850 (4079)
CSG-FB 160	3100 (122)	1500 (59)	2250 (89)	2000 (79)	1650 (3638)	2200 (4850)	2550 (5622)

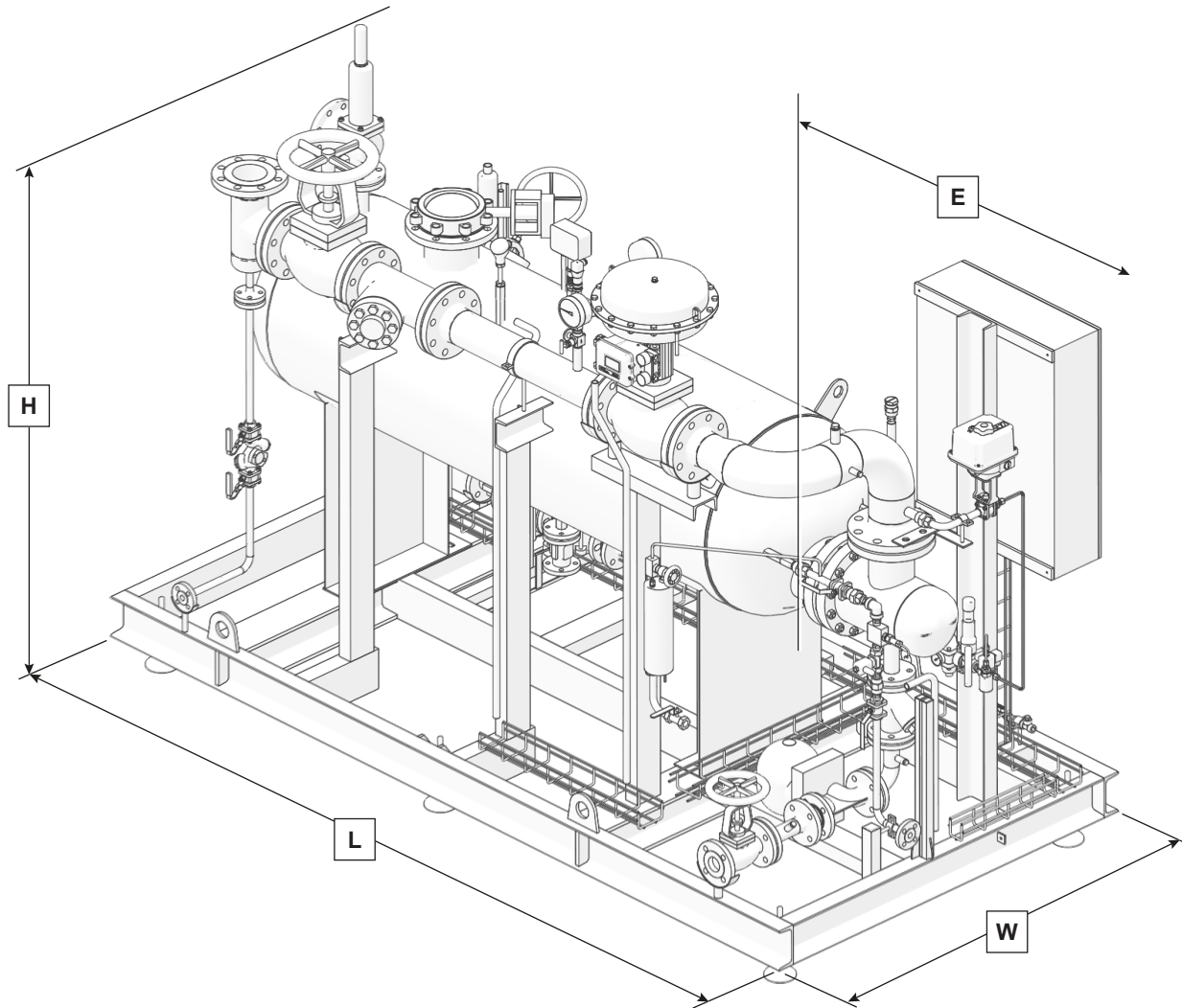

Connections

	Metric				Imperial			
	020	050	110	160	020	050	110	160
Plant steam inlet connection	DN32 PN16	DN50 PN16	DN80 PN16	DN100 PN16	1¼" ANSI 150	2" ANSI 150	3" ANSI 150	4" ANSI 150
Condensate outlet connection	DN25 PN16	DN25 PN16	DN40 PN16	DN40 PN160	1" ANSI 300	1" ANSI 300	1½" ANSI 300	1½" ANSI 300
Clean steam outlet connection	DN50 PN40	DN80 PN40	DN125 PN16	DN150 PN16	2" ANSI 300	3" ANSI 300	5" ANSI 300	6" ANSI 300
Feedwater inlet connection	DN15 PN40	DN20 PN40	DN25 PN40	DN32 PN40	½" ANSI 300	¾" ANSI 300	1" ANSI 300	1¼" ANSI 300
Safety valve discharge	1" G-f	DN50 PN16	DN80 PN16	DN80 PN16	1" NPT	1¼" NPT*	3" NPT	3" NPT
Drain connection	DN25 PN40	DN25 PN40	DN25 PN40	DN25 PN40	1" ANSI 300	¾" ANSI 300	1" ANSI 300	1" ANSI 300
Plant steam condensate drain connection	DN15 PN40	DN15 PN40	DN15 PN40	DN15 PN40	½" ANSI 150	½" ANSI 150	½" ANSI 150	½" ANSI 150
TDS Blowdown connection	DN15 PN40	DN15 PN40	DN15 PN40	DN15 PN40	½" ANSI 150	½" ANSI 150	½" ANSI 150	½" ANSI 150
Sampling system (cooling water in/ out-sample out)	½" BSP- 6 mm	½" BSP- 6 mm	½" BSP- 6 mm	½" BSP- 6 mm	½" BSP	½" BSP	½" BSP	½" BSP
Options								

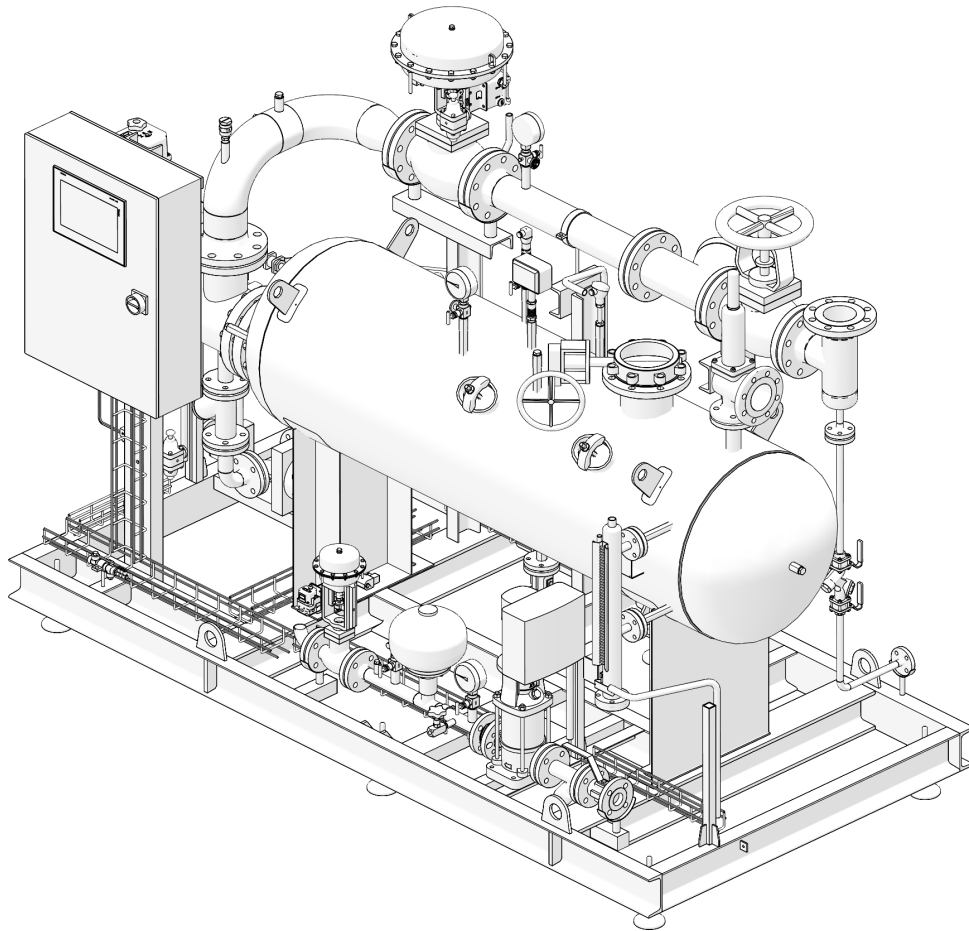

Product nomenclature and selection guide

The product nomenclature is based on the characteristics of the main elements and options, identified as follows:

Basic configuration		Selection	
Design code	E	EN	E
	A	ASME	
	G	GB	
	J	JBA	
Shell type	S	Flanged openable-shell and tube, flanged openable without integrated deaerator	S
Unit size	020	Up to 200 kg/h (440 lbs/hr)	020
	050	Up to 500 kg/h (1002 lbs/hr)	
	110	Up to 1100 kg/h (2425 lbs/hr)	
	160	Up to 1600 kg/h (3527 lbs/hr)	
Valve actuation type	PN	Pneumatic (fail-safe)	PN
	EL	Electric (fail-safe)	
Control	P1	ABB AC500 series + 7" display	P3
	P2	Allen-Bradley CompactLogix 1700 series + 7" display	
	P3	Siemens S7.1200 series + 7" display	
	P4	Selective Control Panel (with PLC ABB AC500 series + 7" display)	
Communication interface	C0	None	C1
	C1	BACnet IP	
	C2	Profinet	
	C3	Modbus TCP/IP	
	C4	BACnet MSTP	
	C5	Profibus	
	C6	Modbus RTU	
	C7	BACnet (BTL cert.) IP	
C8	BACnet (BTL cert.) MSTP		
Unit frame/Electrical cabinet	0	Base and cabinet made of carbon steel, painted	1
	1	Open frame and cabinet made of carbon steel, painted	
	2	Frame w. side panels and cabinet made of carb. steel, painted	
	3	Base and cabinet made of stainless steel (304) *	
	4	Open frame and cabinet made of stainless steel (304) *	
	5	Frame with side panels and cabinet made of stainless steel (304) *	
	7	Seismic, Base and cabinet made of carb. steel, painted	
Control Panel location	S	Side	S
Insulation	1	Steam generator body only	2
	2	Steam generator and hot piping	
	3	Insulation to EnEV specification	
	0	Not insulated	

* This option/configuration is not allowed with P4 control (Selective Control Panel)

Product nomenclature and selection guide continued on next page

Product nomenclature and selection guide (continued)

Handling wheels and feet	N	None (only plates with anchor holes are provided)	F
	F	Adjustable feet	
	W	Pivoting wheels, lockable, with feet	
Plant steam inlet shut-off valve	M	Manual stop valve	M
	AE	Automatic electric isolation valve *	
Plant steam line trapping	N	None	T
	T	Plant steam line trapping station	
TDS control system	1	Timed TDS blowdown	2
	2	TDS control with external probe (discontinuous metering) *	
Sampling cooler	N	None	S
	S	Sample-cooler and sampling valve	
Feedwater pressurisation system	N	None (water P > clean steam P + 0,5 bar g)	P
	P	Pump with VFD *	
Independent downstream plant protection	N	None	T
	T	Temperature limiter *	
Feedwater pre-heating	N	None	N
	PR	Feedwater pre-heating by heat recovery from primary condensate	
Intelligent diagnostics	N	None	I1
	I1	System diagnostics *	
	I3	Integrity test *	
	I4	System diagnostics + Integrity test *	
Clean steam outlet shut-off valve	N	None	N
	M	Manual stop valve	
	AE	Automatic electric isolation valve *	
Test and certifications	S	EU PED test and CE marking of the assembly	S
	U	ASME U stamp	
	M	MOM compliance	
	K	KGS compliance	
	D	DOSH compliance	
	GC	GB standard in Chinese language	
	GE	GB standard in English language	
	SF	None (as assembly)	
R	UKCA		
Level indicator	V	Viscorol (Magnetic Level Indicator)	V

* This option/configuration is not allowed with P4 control (Selective Control Panel)

Product nomenclature example

CSG-FB E S 020-PN P3 C1-1 S 2 F-M T-2 S P T N I1-N S V

Not all configurations are available in every country. Please contact your local Spirax Sarco representative for more details.