



CRU 200 and 500 Series Condensate Recovery Units (VSD pumps)

Description

The Spirax Sarco CRU 200 and 500 condensate recovery units with VSD (variable speed drive) pumps are designed to handle hot flashing condensate, which is commonly used as boiler feed water. The pumps have variable speed drives which provide significant energy saving over traditional fixed speed pumps.

The standard range can handle quantities up to 20 m³/hr, duty/assist up to 98 °C (receiver temperature) with varying delivery heads up to 49 m. For duties outside these parameters please contact Spirax Sarco.

The package comprises of receiver, frame, pumps, valves and level controls.

Note: System head regulation valves are not supplied as part of this unit. The finished unit is leak tested.

It is recommended that a regulation valve is incorporated into the discharge pipework.

Receiver

Receivers are manufactured from 304 stainless steel. They are fitted with an adequately sized vent, overflow and inlet connections flanged to PN16. A water level gauge is fitted as standard, with integrated level control and high alarm.

Frame

The frames are manufactured from stainless steel 304.

Pumps (variable speed drive)

Pump housing and impellers are constructed from stainless steel and are designed for low NPSH conditions to handle hot condensate with the minimum of flooded suction.

There is a graphical display on the "primary" pump providing system performance data. On the "secondary" pump there is a visual status indicator.

The pumps include a frequency converter and PI controller, this enables continuously variable control of the motor speed, to maintain a constant level within the receiver.

The motor efficiency is classified as IE5 in accordance with IEC 60034-30-2.

IP Protection: Pump enclosure IP55.

Control

The units are preconfigured to provide a plug and a play solution. Receivers are fitted with Spirax Sarco Colima Viscorol level indicator providing a 4-20 mA level signal. The system offers duty/assist control of the pumps to maintain a factory set constant level within the receiver. The control system will alternate the duty cycle and provide equal usage on each pump. To achieve the Maximum stated Condensate load both pumps will need to operate together. Should one pump fail the other will continue to operate and attempt to maintain a steady level in the receiver. Dry Run protection is included to shut off the pumps in the event of the receiver being completely emptied, thus preventing pump damage. Included is dry run protection to prevent the pumps being operated without a condensate load, thus preventing pump damage. The unit includes lamps (Power on, warning, alarm, and high level) to display its operational health, plus volt free contacts for remote indication.

Electrical supply: 380 V 4 wire 3 phase 50/60 Hz <16 A.

Volt free contacts: 3-off double throw relay outputs, maximum switching voltage is 240 Vac or 125 Vdc. Switching current 10A Max.

Pump fitting

The motors and pumps are mounted under the receiver and are each connected to suction pipework incorporating isolation valves. Each pump discharge is fitted with a non-return valve suitable to connect to a PN16 flange. IP Protection: Control panel enclosure IP65.

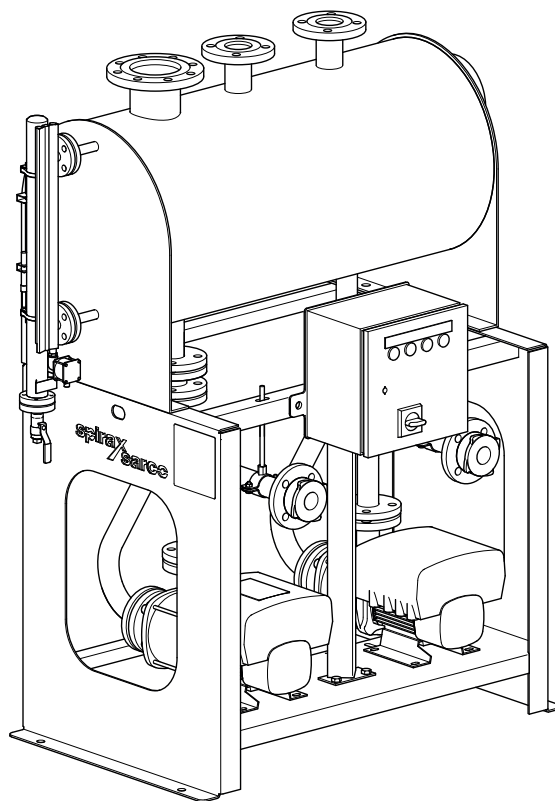

Standards

This product fully complies with the following directives

- European Machinery Directive 2006/42/EC.
- European Electromagnetic Compatibility Devices Directive 2014/30/EU.

The receiver is not a pressurised vessel and is designed to operate at atmospheric pressure and therefore falls outside the scope of EU Pressure Equipment Directive/UK Pressure Equipment (Safety) Regulations.

Materials

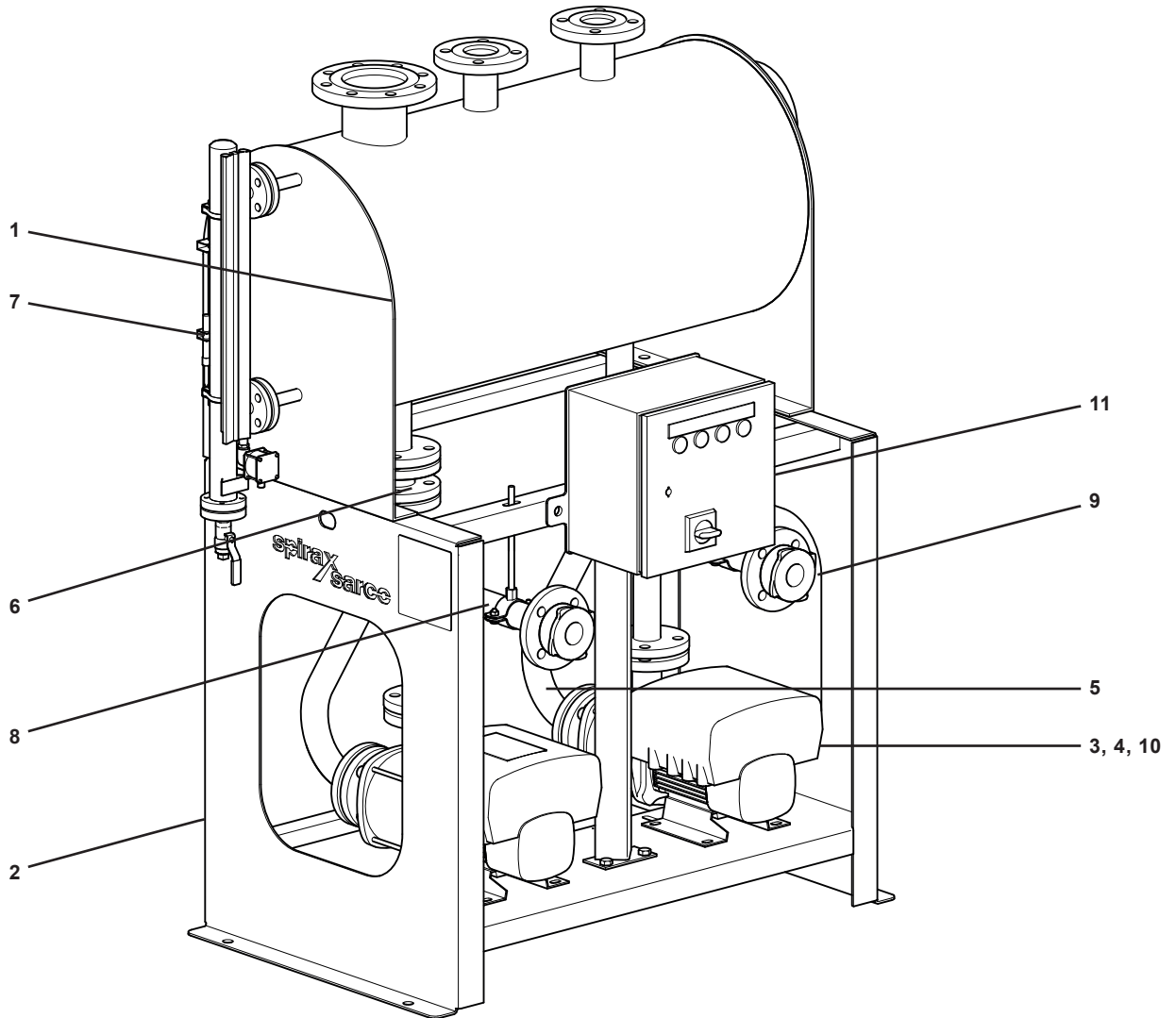

No.	Part	Material
1	Receiver	304 stainless steel
2	Frame	304 stainless steel
3	Pump casing	304 stainless steel
4	Pump impeller	304 stainless steel
5	Suction pipework	304 stainless steel
6	Isolation valves	304 stainless steel

No.	Part	Material
7	Gauge glass	304 stainless steel/Polycarbonate
8	Discharge pipework	304 stainless steel
9	Check valve	Stainless steel (WS 1.4581)
10	Motor casing	Silumin (Alu)
11	Panel	304 stainless steel
12	Cable covering (not shown)	Adaptaflex

Dimensions (approximate) in mm

CRU 200	A	B	C	D	E	F	G	H	J	K	L	M	N	P	Q	R
CRU200-2D-CME33-VSD-SS	1595	600	1335	685	990	180	250	275	1310	255	485	1050	235	520	750	850
CRU200-4D-CME102-VSD-SS		665													730	
CRU 500																
CRU500-4D-CME102-VSD-SS	2100	665	1835	750	1250	205	350	300	1570	375	550	1310	300	650	845	900
CRU500-5D-CME151-VSD-SS															830	
CRU500-5D-CME152-VSD-SS		680														

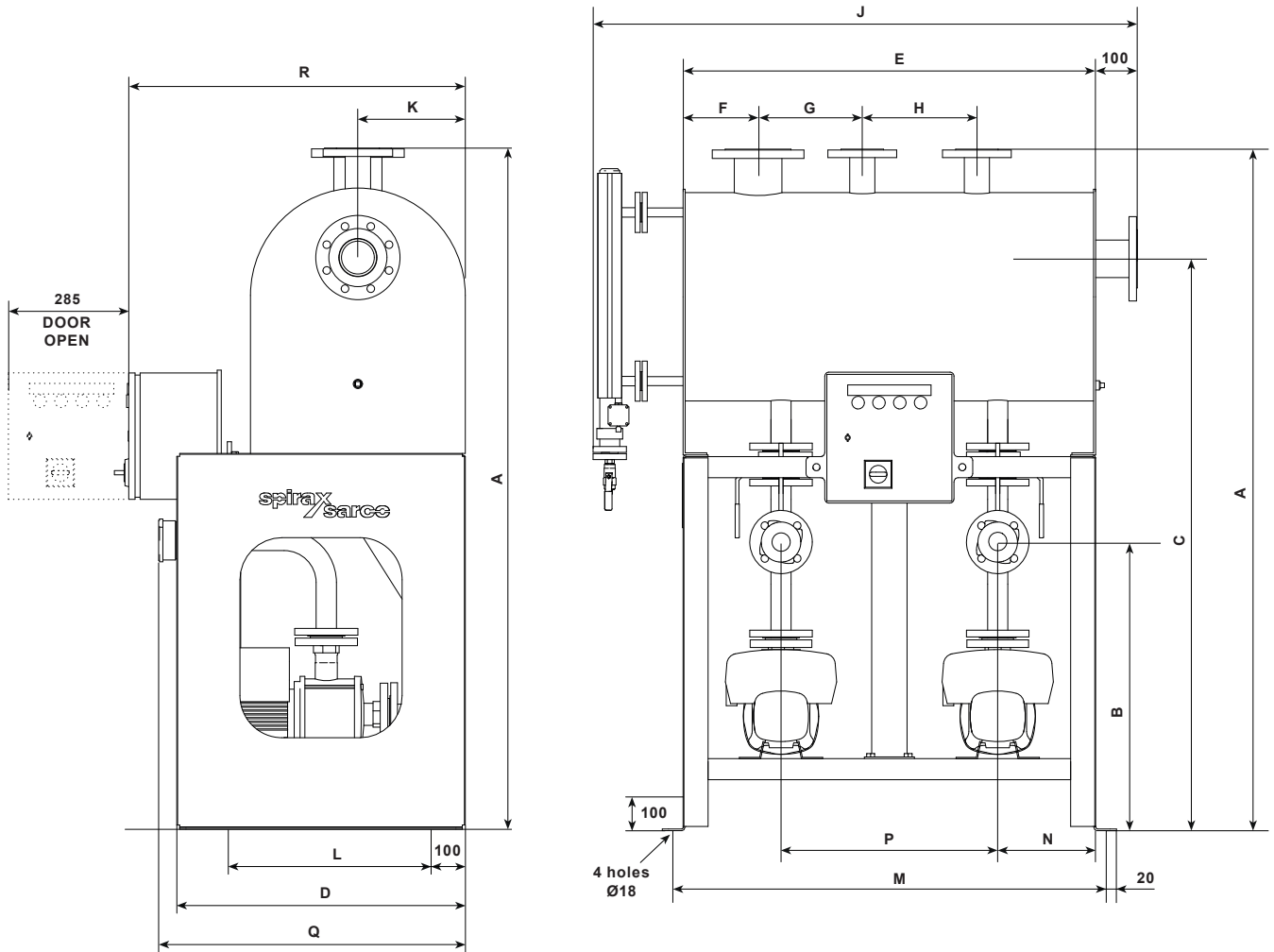

Inlet and outlet connection and weights (approximate in kg)

CRU 200	Connections	V	W	X	Y	Z	Weight
		Outlet	Overflow	Vent	Inlet	Inlet	
CRU200-2D-CME33-VSD-SS	PN16	DN25	DN80	DN100	DN50	DN50	TBA
CRU200-4D-CME102-VSD-SS		DN40	DN80	DN100	DN50	DN50	TBA
CRU 500							
CRU500-4D-CME102-VSD-SS	PN16	DN40	DN80	DN100	DN80	DN80	TBA
CRU500-5D-CME151-VSD-SS		DN50	DN80	DN100	DN80	DN80	TBA
CRU500-5D-CME152-VSD-SS		DN50	DN80	DN100	DN80	DN80	TBA

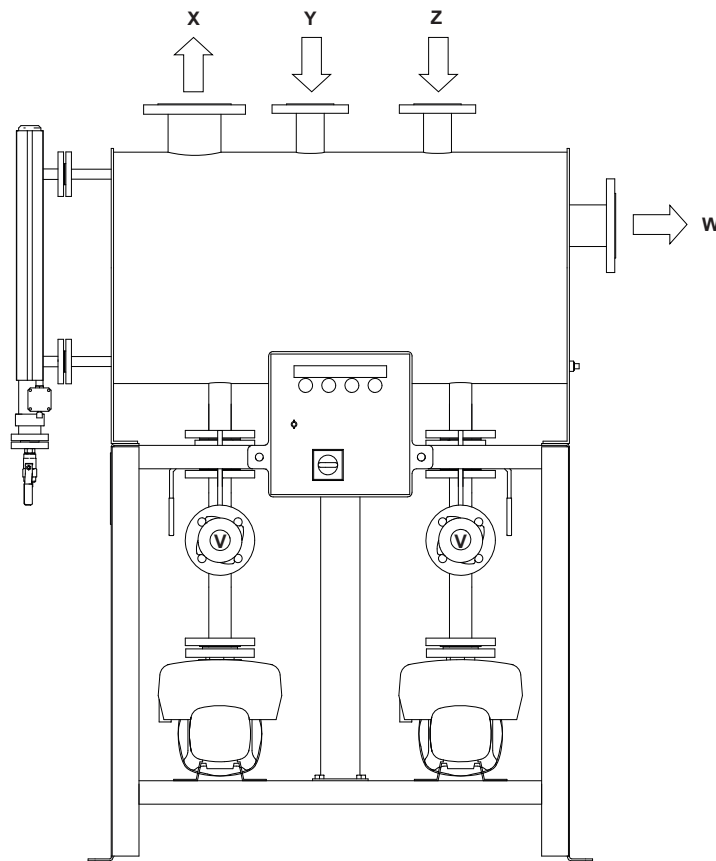

Nozzle Loading

It is the customers responsibility to support piping connected to this unit. To ensure no additional loads are placed on the connection nozzles.

Vent pipework sizing

Consideration should be given to increasing the Vent Pipework from the receiver to prevent excessive back pressure and loss of the Overflow water seal. This is particularly important where the Vent Pipe run is longer than 10 m, has more than two elbows in the run or where there is known to be a substantial amount of Flash Steam in the condensate return pipework to the receiver.

Based on a 10 m equivalent length (including fittings) Vent Pipe capacities are shown in the table opposite

Flash Steam up to (kg/hr)	Vent Pipework nb (mm)
150	80
200	100
400	125
500	150
1000	200
1500	250

Sizing and selection – Duty/assist pumps

Information required for sizing and selection:

1. Maximum load at which condensate returns to the receiver in m³/hr.
2. Total pumping delivery head, including lift and friction losses in pipework and fittings.

Sizing and selection

For correct selection plot the condensate return rate to be handled against the total head required (static + friction) and select the appropriate unit. If selection is borderline then select the next largest unit.

Selection example: The condensate return rate is 2 m³/hr and the total head required is 30 m. Draw a horizontal line from the known 30 m head required until it intersects with the vertical line that represents the 2 m³/hr of condensate to be handled. For this example the selection would be a CRU200-2D-CME33-VSD-SS.

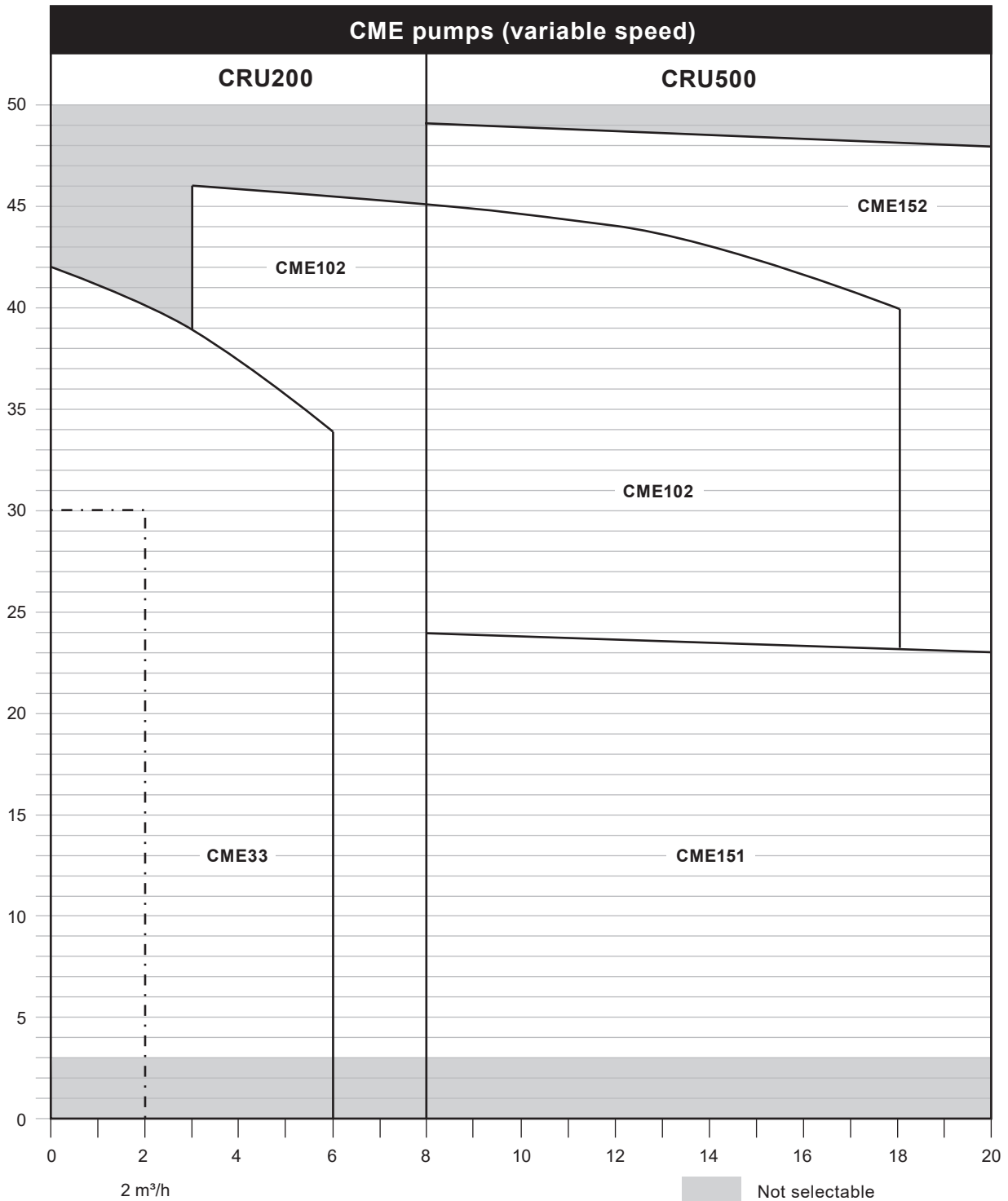

Nomenclature

Unit		CRU	CRU
Receiver volumes (l)		200	200
		500	
Pump outlet size (D = Duplex pumps)	DN25	2D	2D
	DN40	4D	
	DN50	5D	
Pump selection		CME33-VSD	CME33-VSD
		CME102-VSD	
		CME151-VSD	
		CME152-VSD	
Frame	Stainless steel	SS	SS

Typical specification

The selection shown above is a CRU200-2D-CME33-VSD-SS condensate recovery unit, with a stainless steel frame, designed and built to handle 2 m³/hr of condensate against a required delivery head of 30 m.

How to order

Example: 1 off CRU200-2D-CME33-VSD-SS condensate recovery unit.

Certification

A declaration of conformity to EN 10204 2.1 is available on request.

Standard Options

- Loop seal kit (supplied loose) piping in stainless steel 304.

Bespoke Options (contact Spirax Sarco)

- ANSI 150 connections.
- CRU units with pumps operating duty/standby.