



## CA46 and CA46S Austenitic Stainless Steel Air and Gas Traps Flanged DN15 to DN25

### Description

The CA46 is an austenitic stainless steel ball float air and gas trap. It is available with a soft valve cone given designation CA46 or with a metal valve cone given designation CA46S both having horizontal flanged connections. The cover will be drilled and tapped  $\frac{1}{2}$ " BSP or NPT for the purpose of fitting a balance line. Body and cover castings are produced by a TÜV approved foundry.

### Standards

This product fully complies with the requirements of the Pressure Equipment Directive (PED) and carries the  mark when so required.

### Certification

The product is available with material certification to EN 10204 3.1.

**Note:** All certification/inspection requirements must be stated at the time of order placement.

### Sizes and pipe connections

**CA46** - DN15 and DN20

**CA46S** - DN15, DN20 and DN25

#### Standard flanges are:

- EN 1092 PN40 with DIN face-to-face dimensions.
- ASME 150, ASME 300 and JIS/KS 20 flanges are provided with drilled and tapped bolt holes with DIN face-to-face dimensions.

**Balance line** - PN flanges will be provided with BSP balance line and ASME and JIS/KS 20 flanges with NPT balance line.

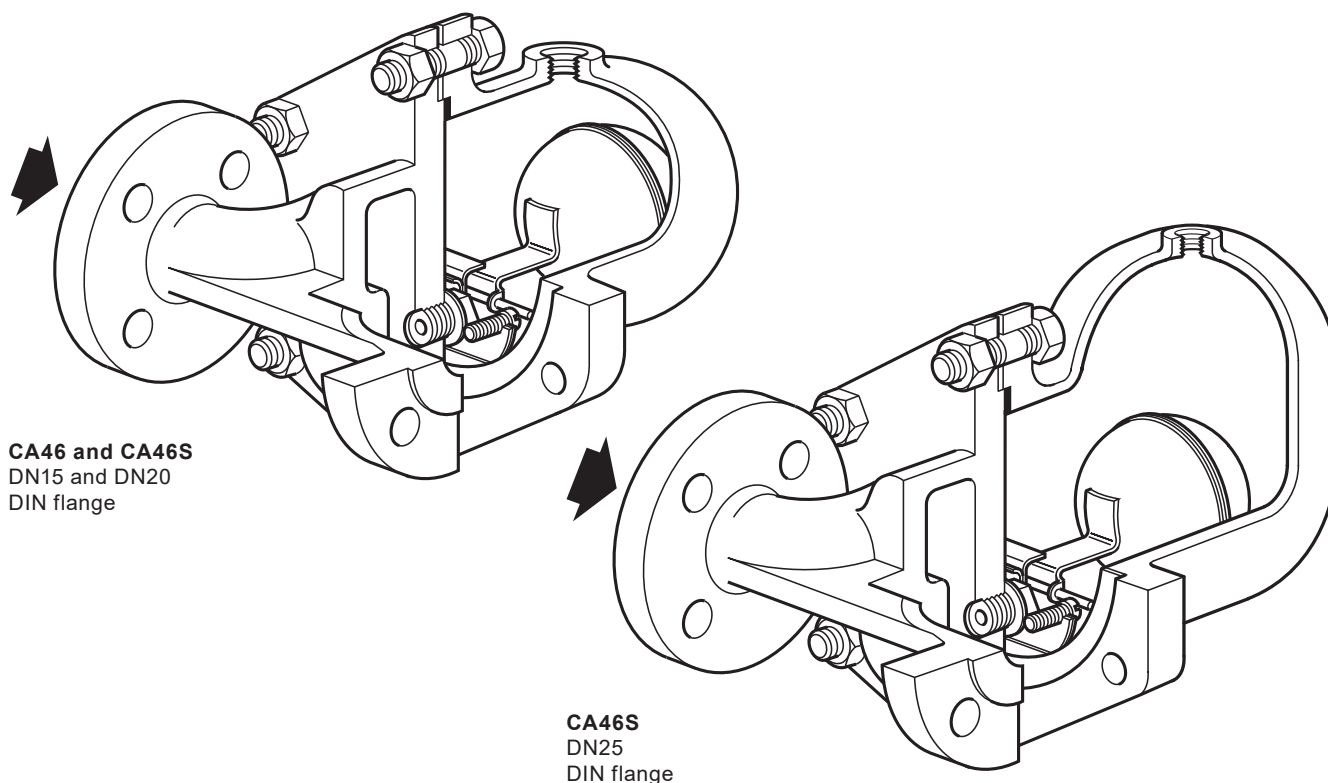

## Pressure/temperature limits

**CA46 - DN15 and DN20 flanged**

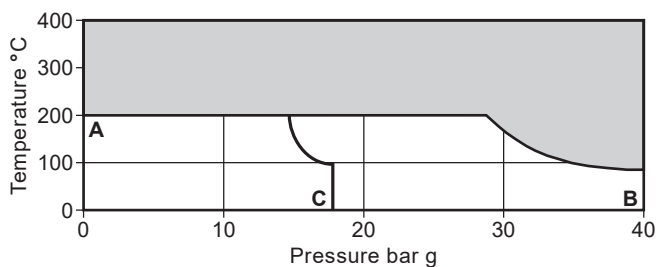

**CA46S - DN15, DN20 and DN25 flanged**

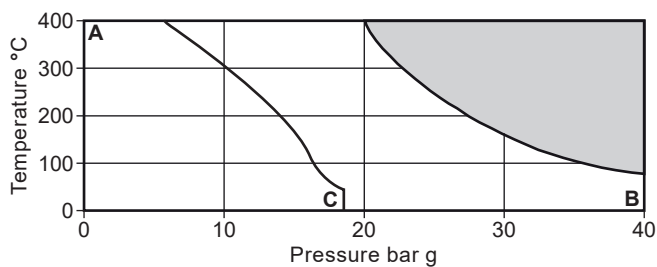

The product **must not** be used in this region.

**A - B** Flanged EN 1092 PN40 and ASME 300.

**A - C** Flanged ASME 150 and JIS/KS 20K.

Body design conditions		PN40
PMA	Maximum allowable pressure	40 bar g @ 80 °C
TMA	Maximum allowable temperature	<b>CA46</b> 200 °C @ 29 bar g
		<b>CA46S</b> 400 °C @ 20 bar g
Minimum allowable temperature		0 °C
PMO	Maximum operating pressure	40 bar g @ 80 °C
TMO	Maximum operating temperature	<b>CA46</b> 200 °C @ 29 bar g
		<b>CA46S</b> 400 °C @ 20 bar g
Minimum operating temperature		0 °C

**Note:** For lower operating temperatures consult Spirax Sarco

	Specific gravity					
	Trap	1.0	0.9	0.8	0.7	0.6
$\Delta$ PMX Maximum differential pressure	<b>CA46-32</b>	32.0	32.0	29.0	20.0	12.0
	<b>CA46S-4.5</b>	4.5	4.5	4.5	3.4	2.0
	<b>CA46S-10</b>	10.0	9.5	6.8	5.5	3.4
	<b>CA46S-14</b>	14.0	14.0	11.0	8.0	5.0
	<b>CA46S-21</b>	21.0	19.0	15.0	10.0	6.5
	<b>CA46S-32</b>	32.0	30.0	23.0	16.5	10.0

Designed for a maximum cold hydraulic test pressure of:	PN40	60 bar g
	ASME 300	60 bar g
	ASME 150	30 bar g
	JIS/KS 20K	49 bar g

**Caution:** The trap in its complete operational form must not be subjected to a pressure of greater than 48 bar otherwise damage to the internal mechanism may result.

## Materials

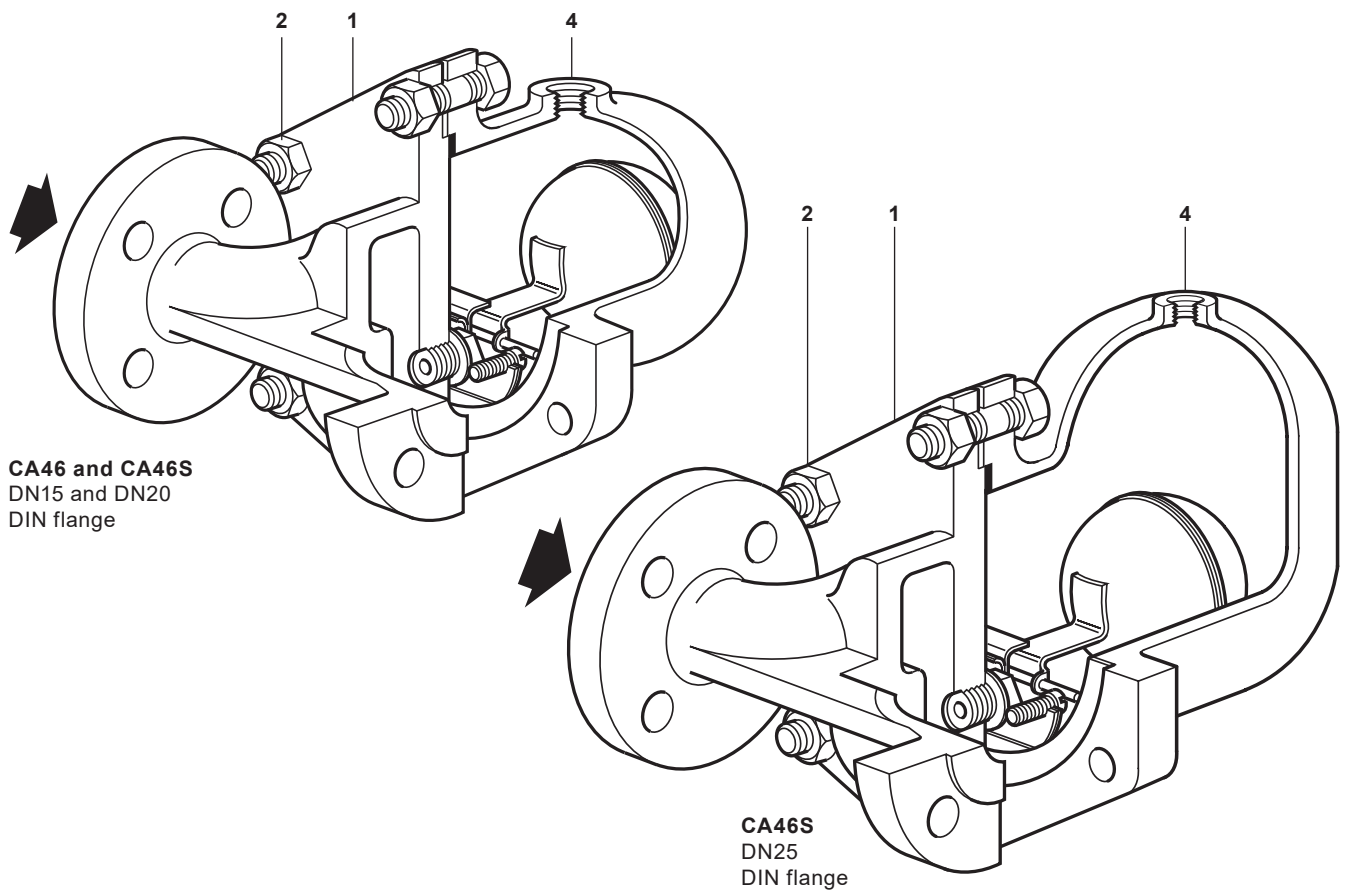

No.	Part	Material	
1	Body	Austenitic stainless steel (316)	1.4408/CF8M
2	Cover stud	Austenitic stainless steel	BS 6105 A2-70
	Cover nut	Austenitic stainless steel	BS 6105 A2
3	Cover gasket (shown on page 4)	Austenitic stainless steel	BS 1449 304 S16
4	Cover	Austenitic stainless steel	1.4408/CF8M

Materials continued on page 4

## Materials (continued)

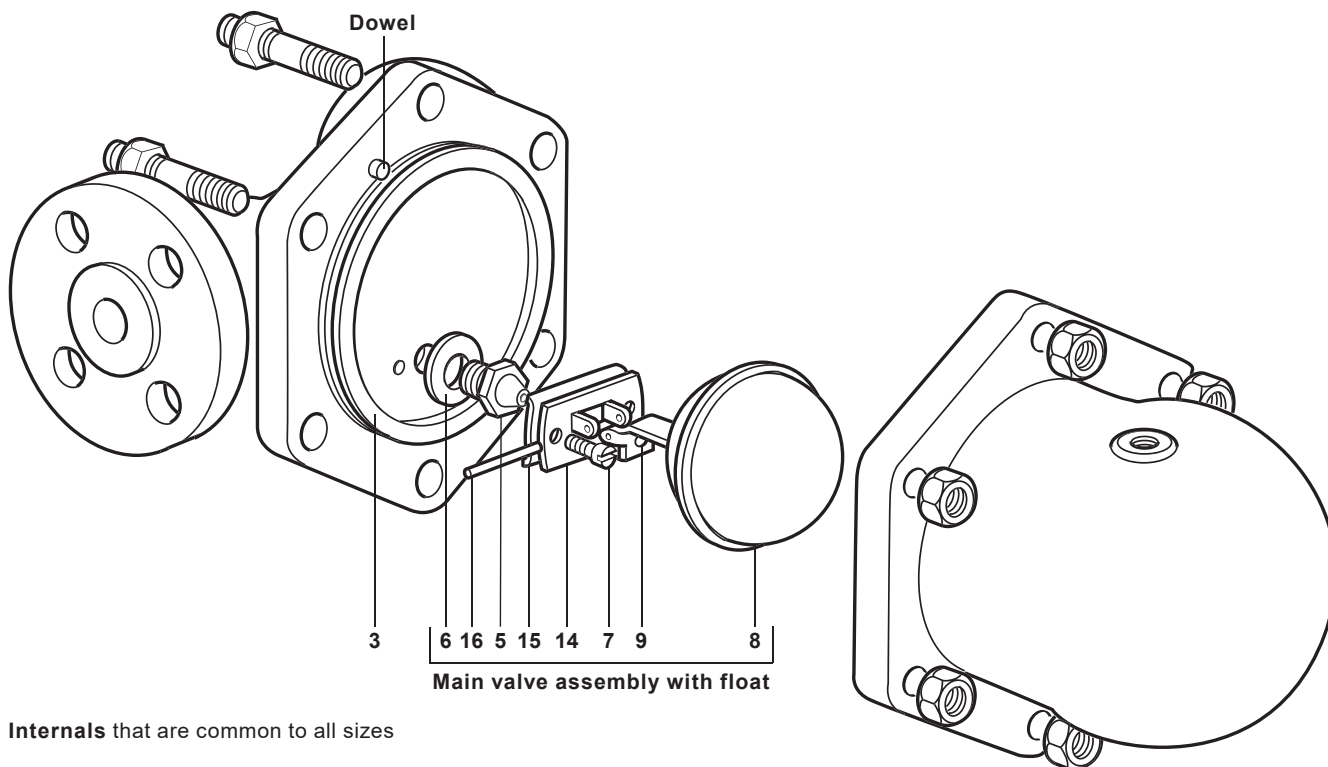

Internals that are common to all sizes

No.	Part	Material	
5	Valve seat	Stainless steel	BS 970 431 S29
6	Valve seat gasket	Stainless steel	BS 1449 304 S11
7	Pivot frame assembly	Stainless steel set screws	BS 4183 18/8
8	Ball float and lever	Stainless steel	BS 1449 304 S16
	<b>CA46</b>	Synthetic rubber	Viton
9	Valve cone <b>CA46S</b> (The valve cone in the CA46S is permanently attached to the ball float and lever)	Stainless steel	
14	Support frame	Stainless steel	BS 1449 304 S16
15	Pivot frame	Stainless steel	BS 1449 304 S16
16	Pivot	Stainless steel	

# Capacities

**Note:** The capacities provided here are calculated using water at ambient temperature. The discharge capacity is affected with a change in specific gravity, for further information contact Spirax Sarco.

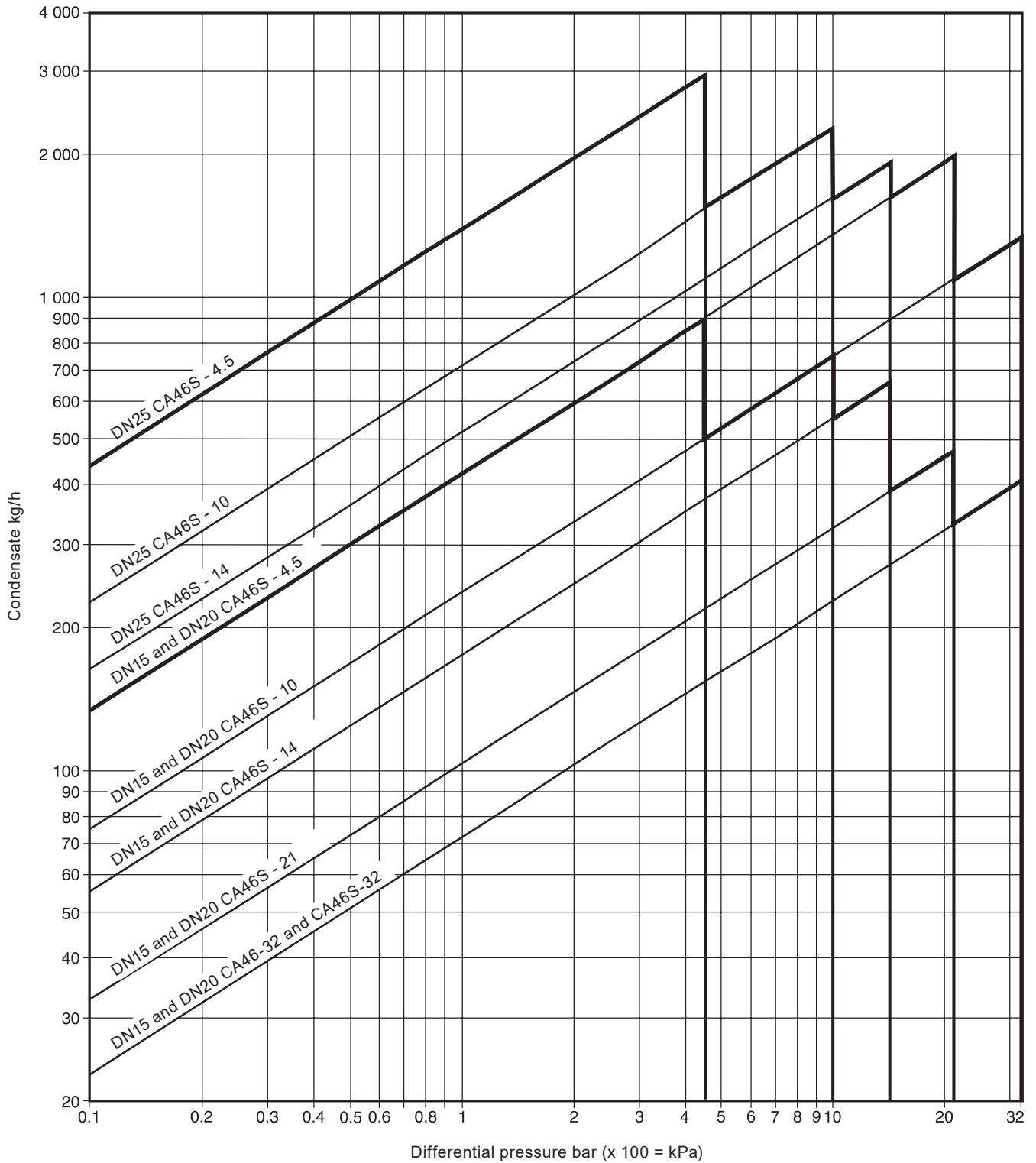

## Dimensions/weights (approximate) in mm and kg

Size	A	B	C	D	E	F	G	Weight
DN15	150	80	80	215	120	155	155	10.8
DN20	150	80	80	225	120	165	165	10.8
DN25	160	115	85	282	170	215	215	15.0

### CA46S DN25 DIN flange

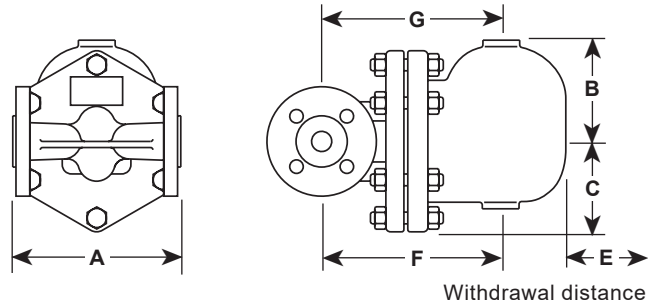

### CA46 and CA46S DN15 and DN20 DIN flange

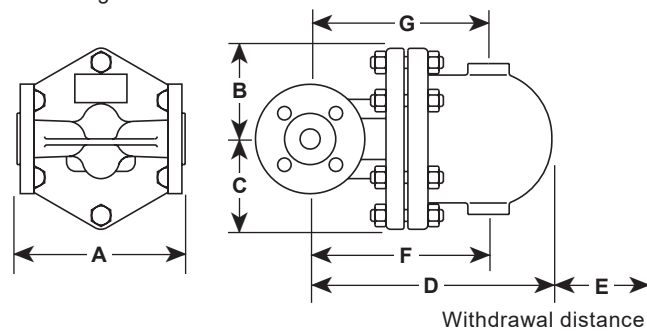

### Flange bolt hole tapings

Size	ASME 150	ASME 300	JIS/KS 20
DN15	1/2" - 13 UNC - 2B	1/2" - 13 - UNC - 2B	M12
DN20	1/2" - 13 UNC - 2B	1/2" - 13 - UNC - 2B	M12
DN25	1/2" - 13 UNC - 2B	5/8" - 11 - UNC - 2B	M16

## Safety information, installation and maintenance

For full details see the Installation and Maintenance Instructions (IM-P148-37) supplied with this product.

### Installation note:

The trap should be fitted in the horizontal plane below what it is draining, with the direction of flow as indicated on the body so that the float mechanism is free to rise and fall in a vertical plane.

One of the advantages of the float trap for draining air and gas systems is that no bleed is required for satisfactory operation. However, because the trap has no bleed a separate balance line is needed to prevent it becoming air or gas locked.

Make sure that the balance line is piped back to the upstream side.

**A balance line is essential for the correct operation of this product.**

For convenience of maintenance it is recommended that a union is fitted in the balance line near to the trap cover.

### Disposal:

The product is recyclable. No ecological hazard is anticipated with the disposal of this product providing due care is taken.

## How to order

**Example:** 1 off Spirax Sarco DN25 CA46S-32 air and gas trap flanged to EN 1092 PN40 with austenitic stainless steel body and cover.

## Spare parts

The spare parts available are shown in solid outline. Parts drawn in a grey line are not supplied as spares.

### Available spare



Soft valve cone CA46	(packet of 3)	<b>9</b>
Main valve assembly with float	<b>CA46</b>	<b>5, 6, 7, 8, 9, 14, 15, 16</b>
	<b>CA46S</b>	<b>5, 6, 7, 8 + 9, 14, 15, 16</b>
Complete set of gaskets	(packet of 3 sets)	<b>3, 6</b>

### How to order spares

Always order spares by using the description given in the column headed 'Available spares' and state the size and type of trap.

**Example:** 1 - Main valve assembly for a Spirax Sarco DN25 CA46S-32 air and gas trap.

## Recommended tightening torques

Item	 or mm		N m
2	17	M10 x 60	29 - 33
5	17	M12 x 8	50 - 55
7	Cheesehead	M5 x 20	2.5 - 2.8

