



BSAT and BSA Bellows Sealed Stop Valves

Description

A range of sealed, in-line stop valves having twin ply bellows as standard throughout the range. These valves have been designed for use on steam, gas, liquid, condensate and water systems.

The standard BSAT range comes complete with throttling plug and locking device.

The alternative BSA range has a flat disc.

The Tables on page 2 clearly display the available sizes, pipeline connections and available options for the standard and alternative ranges.

Standards

The product fully complies with the requirements of the EU Pressure Equipment Directive/UK Pressure Equipment Regulations and carries the  mark when so required.

Certification

The BSA1 and BSA1T is available with a manufacturer's Typical Test Report. The BSA2, BSA2T, BSA3, BSA3T, BSA6T and BSA64T is available with certification to EN 10204 3.1.

Note: All certification/inspection requirements must be stated at the time of order placement.

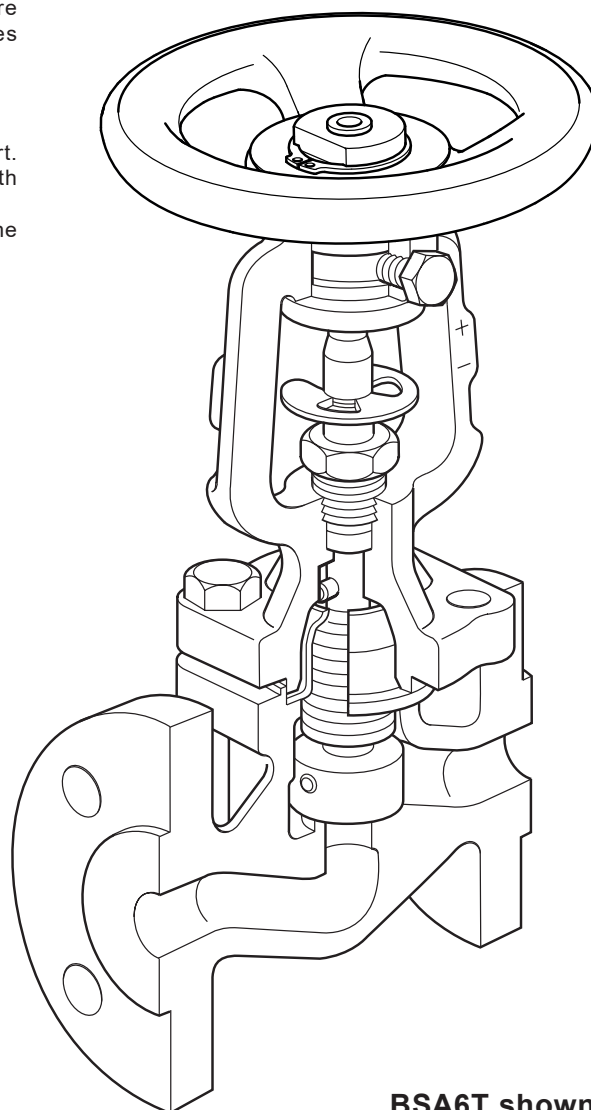

BSA6T shown

Range and options

Standard BSAT range - complete with throttling plug and locking device

| Material | | Cast iron | | SG iron | | Cast steel | | | | Stainless steel | Stainless steel/ cast steel | |
|-----------------------|-------|-----------|-------|---------|------|------------|------|----------|----------|-----------------|--------------------------------|------|
| Model and connections | | BSA1T | | BSA2T | | BSA3T | | | | BSA6T | BSA64T | |
| | | PN16 | KS 10 | PN16 | PN25 | PN25 | PN40 | ASME 150 | ASME 300 | KS 20 | PN40 | PN40 |
| Sizes | DN15 | • | • | • | • | | • | • | • | • | • | • |
| | DN20 | • | • | • | • | | • | • | • | • | • | • |
| | DN25 | • | • | • | • | | • | • | • | • | • | • |
| | DN32 | • | • | • | • | | • | | | | • | • |
| | DN40 | • | • | • | • | | • | • | • | • | • | • |
| | DN50 | • | • | • | • | | • | • | • | • | • | • |
| | DN65 | • | • | • | • | | • | | | | • | • |
| | DN80 | • | • | • | • | | • | • | • | • | • | • |
| | DN100 | • | • | • | • | | • | • | • | • | • | • |
| | DN125 | • | • | • | • | | • | | | | | |
| | DN150 | • | • | • | • | | • | | • | • | | |
| | DN200 | • | • | • | • | • | | | • | • | | |
| | DN250 | | | | • | | | | | | | |

| | | | | | | | | | | | | |
|---------------------------|-------|---|---|---|---|--|---|---|---|---|---|---|
| Optional R-PTFE soft seat | DN15 | • | • | • | • | | • | • | • | • | • | • |
| | DN20 | • | • | • | • | | • | • | • | • | • | • |
| | DN25 | • | • | • | • | | • | • | • | • | • | • |
| | DN32 | • | • | • | • | | | | | | • | • |
| | DN40 | • | • | • | • | | • | • | • | • | • | • |
| | DN50 | • | • | • | • | | • | • | • | • | • | • |
| | DN65 | • | • | • | • | | | | | | • | • |
| | DN80 | • | • | • | • | | • | • | • | • | • | • |
| | DN100 | • | • | • | • | | • | • | • | • | • | • |

Alternative BSA range - complete with flat disc option

| Material | | Cast iron | | SG iron | | Cast steel | | | | Stainless steel | Stainless steel/ cast steel | |
|-------------------------|-------|-----------|-------|---------|------|------------|------|----------|----------|-----------------|--------------------------------|--|
| Model and connections | | BSA1 | | BSA2 | | BSA3 | | | | | | |
| | | PN16 | KS 10 | PN16 | PN25 | PN25 | PN40 | ASME 150 | ASME 300 | KS 20 | | |
| Sizes | DN125 | • | • | • | • | | • | | | | | |
| | DN150 | • | • | • | • | | • | | • | • | | |
| | DN200 | • | • | • | • | • | | | • | • | | |
| | DN250 | | | | • | | | | | | | |
| Optional balancing disc | DN125 | | | | • | | • | | | | | |
| | DN150 | | | • | • | | • | | • | • | | |
| | DN200 | • | • | • | • | • | | | • | • | | |
| | DN250 | | | | • | | | | | | | |

Dimensions/weights (approximate) in mm and kg

| Size | A | | | | | B | C | Weight | | | | |
|-------|-----|------------|------------|----------|----------|-----|-----|------------------------|---------------|----------------------------|--------------------------------|-------------------------|
| | PN | JIS/KS 10K | JIS/KS 20K | ASME 150 | ASME 300 | | | BSA1 BSA1T BSA2T | BSA3 (DIN) | BSA3 (ASME) ANSI 150 | BSA3 ASME 300 JIS/KS 20K | BSA6T BSA64T PN40 |
| DN15 | 130 | 133 | 152 | 108 | 152 | 205 | 125 | 4 | 4 | 5 | 6 | 4 |
| DN20 | 150 | 153 | 178 | 117 | 178 | 205 | 125 | 4 | 5 | 6 | 7 | 5 |
| DN25 | 160 | 163 | 200 | 127 | 203 | 217 | 125 | 5 | 6 | 8 | 9 | 6 |
| DN32 | 180 | 183 | - | - | - | 217 | 125 | 7 | 8 | - | - | 8 |
| DN40 | 200 | 203 | 224 | 165 | 229 | 243 | 200 | 10 | 11 | 10 | 11 | 11 |
| DN50 | 230 | 229 | 259 | 203 | 267 | 243 | 200 | 12 | 14 | 12 | 15 | 14 |
| DN65 | 290 | 293 | - | - | - | 263 | 200 | 16 | 19 | - | - | 19 |
| DN80 | 310 | 309 | 304 | 241 | 317 | 287 | 200 | 21 | 26 | 25 | 29 | 26 |
| DN100 | 350 | 349 | 340 | 292 | 356 | 383 | 315 | 36 | 44 | 41 | 49 | 44 |
| DN125 | 400 | 395 | - | - | - | 416 | 315 | 52 | 64 | - | - | - |
| DN150 | 480 | 479 | 428 | - | 445 | 450 | 400 | 75 | 88 | - | 94 | - |
| DN200 | 600 | 592 | 537 | - | 559 | 622 | 500 | 145 | 180 | - | 193 | - |
| DN250 | 730 | - | - | - | - | 763 | 500 | *180 | - | - | - | - |

*(BSA2T/BSA2 only)

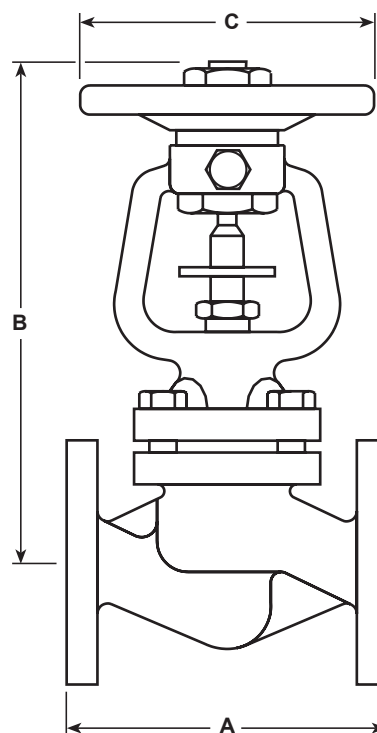

Seat leakage

Disc to seat shut-off conforms to EN 12266-1 Rate A leakage.

K_v values - all options

| Size | DN15 (½") | DN20 (¾") | DN25 (1") | DN32 (1¼") | DN40 (1½") | DN50 (2") | DN65 (2½") | DN80 (3") | DN100 (4") | DN125 (5") | DN150 (6") | DN200 (8") | DN250 (10") | For conversion: C _v (UK) = K _v x 0.963 C _v (US) = K _v x 1.156 |
|----------------|--------------|--------------|--------------|---------------|---------------|--------------|---------------|--------------|---------------|---------------|---------------|---------------|----------------|---|
| K _v | 4 | 7 | 12 | 19 | 30 | 47 | 77 | 120 | 193 | 288 | 410 | 725 | 1145 | |

Note: For K_v values and flow characteristic values of the **BSA1T**, **BSA2T** and **BSA3T** see the next section 'BSAT flow data'.

BSAT flow data

| Size | BSAT valve | | | | | | | | | | | | |
|---------------------|--|------|------|------|------|------|------|-------|-------|-------|-------|-------|-------|
| | DN15 | DN20 | DN25 | DN32 | DN40 | DN50 | DN65 | DN80 | DN100 | DN125 | DN150 | DN200 | DN250 |
| Handwheel rotations | K _v values for given handwheel rotations tested to EN 60534-2-3 Water at 20 °C | | | | | | | | | | | | |
| 0 | 0 | 0 | 0 | 0 | 0 | 0 | 0 | 0 | 0 | 0 | 0 | 0 | 0 |
| 0.5 | 1.2 | 1.2 | 1.4 | 2.2 | 4.4 | 4.1 | 5.6 | 10.4 | 12.0 | 21 | 28 | 66 | 110 |
| 1 | 1.7 | 1.7 | 2.0 | 3.7 | 5.0 | 5.0 | 7.0 | 11.5 | 14.3 | 23 | 30 | 81 | 140 |
| 1.5 | 2.7 | 2.9 | 2.9 | 5.0 | 5.5 | 6.0 | 9.2 | 13.6 | 24.5 | 26 | 33 | 97 | 150 |
| 2 | 3.6 | 4.0 | 4.6 | 7.9 | 7.6 | 7.2 | 11.6 | 16.3 | 34.1 | 42 | 46 | 111 | 165 |
| 2.5 | 4.4 | 5.3 | 6.4 | 10.6 | 11.0 | 9.7 | 12.4 | 18.5 | 59.6 | 67 | 65 | 149 | 190 |
| 3 | 5.4 | 6.6 | 8.5 | 13.8 | 14.7 | 14.1 | 13.0 | 21.1 | 86.2 | 94 | 90 | 199 | 225 |
| 4 | | | 10.6 | 17.0 | 22.6 | 24.4 | 25.2 | 24.5 | 123.0 | 140 | 152 | 302 | 330 |
| 4.5 | | | 11.2 | 18.3 | 24.4 | 29.4 | 32.5 | 29.0 | 139.0 | 181 | 177 | 355 | 451 |
| 5 | | | 11.9 | 19.6 | 27.2 | 37.0 | 43.6 | 39.1 | 164.1 | 185 | 216 | 403 | 460 |
| 6 | | | | | 28.9 | 46.2 | 60.2 | 61.0 | 179.0 | 220 | 264 | 455 | 600 |
| 6.5 | | | | | 29.1 | 47.0 | 63.0 | 69.0 | 186.0 | 230 | 288 | 480 | 641 |
| 6.7 | | | | | 29.3 | 47.2 | 64.3 | 73.0 | | 235 | 293 | 487 | 656 |
| 7 | | | | | | | 65.9 | 78.0 | | 241 | 305 | 495 | 678 |
| 8 | | | | | | | 71.2 | 90.0 | | 259 | 337 | 507 | 738 |
| 8.5 | | | | | | | 74.6 | 92.0 | | | 348 | 522 | 760 |
| 9.5 | | | | | | | | 99.0 | | | 369 | | 793 |
| 10 | | | | | | | | 101.6 | | | | | 805 |
| 10.7 | | | | | | | | | | | | | 827 |

To convert K_v to volume flowrate in m³/h:

$$\dot{Q} = K_v \times \sqrt{\Delta P}$$

Where:

\dot{Q} = Volume flow in cubic m/h

ΔP = Pressure drop in bar

Note: The maximum recommended differential pressure in throttling function:

| | |
|---------------|---------|
| DN15 - DN80 | 2.0 bar |
| DN100 - DN125 | 1.5 bar |
| DN150 | 1.0 bar |
| DN200 - DN250 | 0.8 bar |

If the BSAT is used above these quoted figures, increased noise and vibration may be experienced.

The following graphs show handwheel rotation and flow characteristic with water at 20 °C:

BSAT - DN15

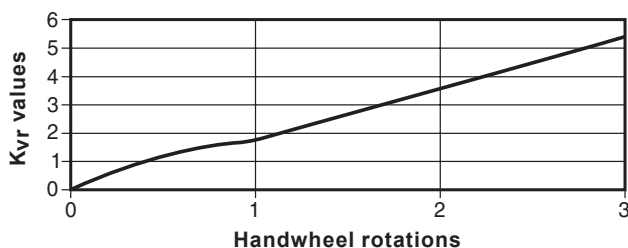

BSAT - DN20

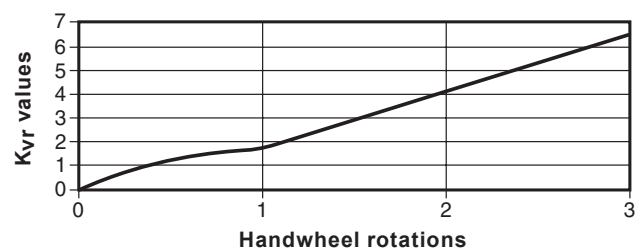

BSAT - DN25

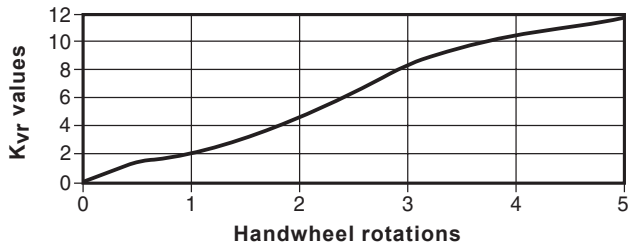

BSAT - DN32

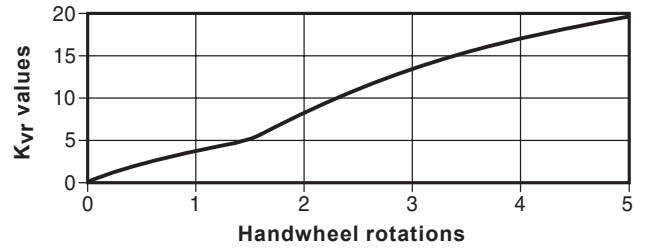

BSAT - DN40

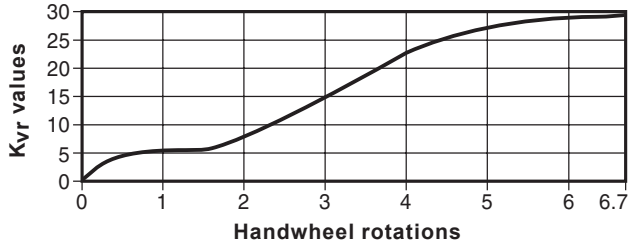

BSAT - DN50

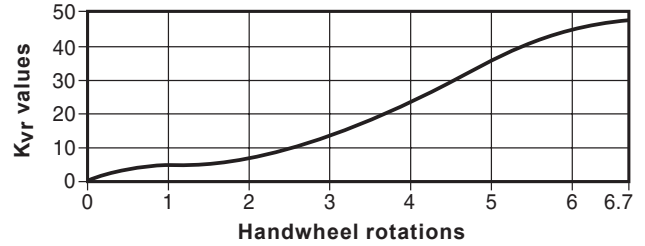

BSAT - DN65

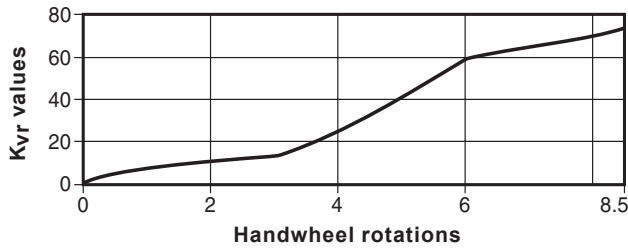

BSAT - DN80

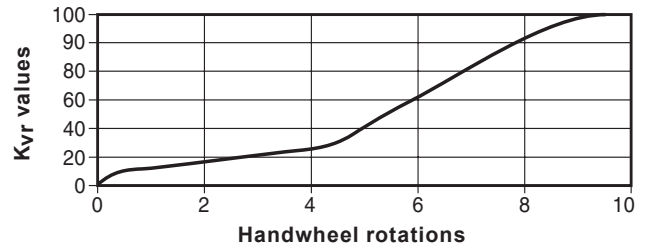

BSAT - DN100

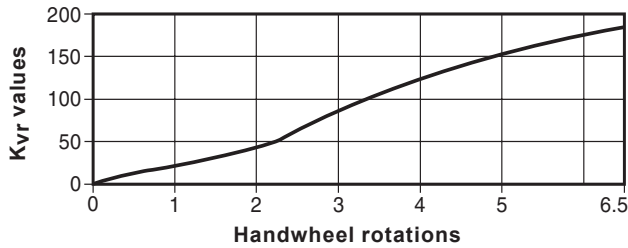

BSAT - DN125

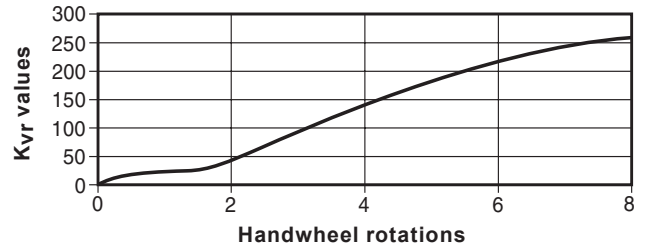

BSAT - DN150

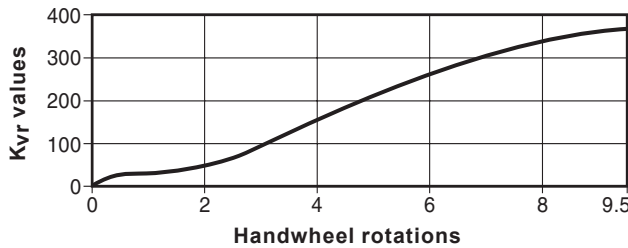

BSAT - DN200

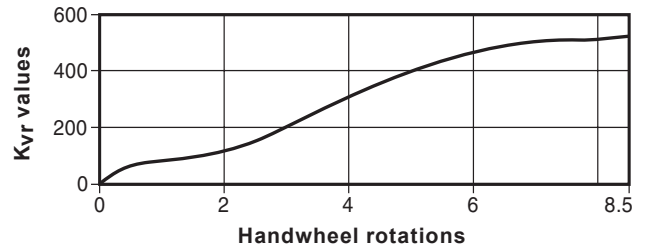

BSAT - DN250

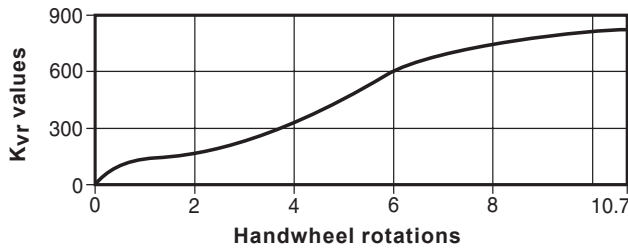

**Typical standard flat disc
for the BSA1, BSA2 and BSA3**

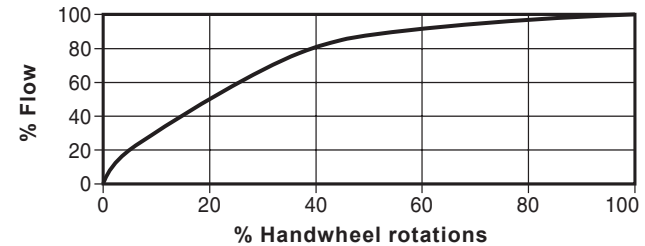

Materials for the BSA1T, BSA2T, BSA3T and BSA1, BSA2, BSA3

| No. Part | BSA1T and BSA1 | BSA2T and BSA2 | BSA3T and BSA3 | |
|-----------------------|--|------------------------------------|---|--|
| | | | DIN | ANSI |
| 1 Body | EN-GJL-250 | SG iron EN-GJS-400-18-LT | Cast steel 1.0619+N (GSC 25N) | Cast steel ASTM A 216 WCB |
| 2 Bonnet | SG iron EN-GJS-400-18-LT | | Steel (DN15 - DN80) DIN 17243 C 22.8 | Forged steel (DN15- DN80) ASTM A 105 |
| | | | Steel (DN100 - DN200) 1.0619+N (GSC 25N) | Cast steel (DN100- DN200) ASTM A 216 WCB |
| 3 Seat | Stainless steel AISI 420 | | | |
| 4 Disc | Metal | Stainless steel DIN 17440 X30 Cr13 | | |
| | Soft seat | Disc | Stainless steel DIN 17440 X30 Cr13 | |
| | | Insert | R-PTFE 25% carbon filled | |
| 5 Bellows | Stainless steel WS 1.4571 EN10028-7 X6 CrNiMTi 17-12-2 | | | |
| 6 Stem | Stainless steel AISI 420 | | | |
| 7 Handwheel | Pressed steel BS 1449 CR4 | | | |
| 8 Stem packing | Graphite | | | |
| 9 Bonnet studs | | Steel DIN 17420 24 Cr Mo 5 | Steel ASTM A 193 B7 | |
| Bonnet nuts | | Steel DIN 17420 Ck 35 | Steel ASTM A 192 2 H | |
| Bonnet bolts | Steel DIN 931 Gr. 5.6 | | | |
| 10 Body/bonnet gasket | Graphite laminated with stainless steel insert | | | |
| 11 Locking screw | DN15 - DN80 | Steel M8 x 14 mm BS 3692 Gr. 8.8 | | |
| | DN100 - DN150 | Steel M8 x 20 mm BS 3692 Gr. 8.8 | | |
| | DN200 - DN250 | Steel M12 x 20 mm BS 3692 Gr. 8.8 | | |
| 12 'D' washer | Mild steel | | | |
| 13 Circlip | Mild steel | | | |
| 14 Protective cap | Plastic | | | |
| 15 Top nut | Steel | | | |

Stroke limiter for throttling versions

The handwheel nut on the **BSA1T, BSA2T and BSA3T** has a threaded hole for provision of a stroke limiter. Customer to supply standard nuts and bolts as indicated in the table below.

| Size | Hexagon bolt |
|--------------|--------------|
| DN15- DN80 | M8 x 50 mm |
| DN100- DN150 | M12 x 75 mm |
| DN200- DN250 | M12 x 100 mm |

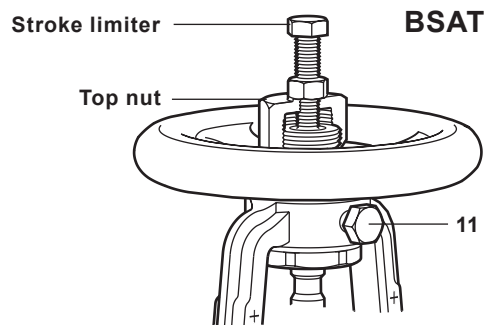

BSAT

BSA

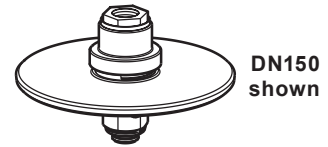
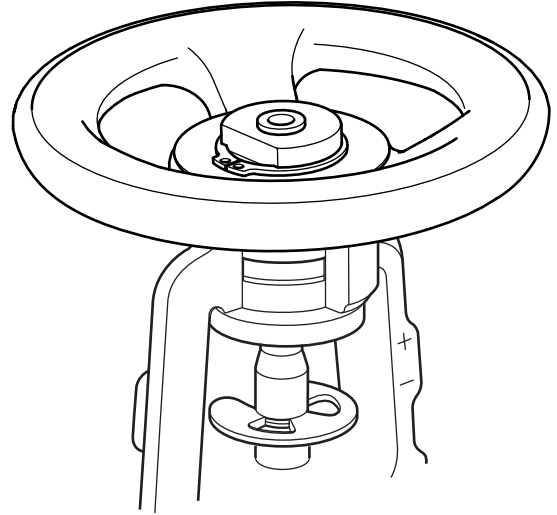
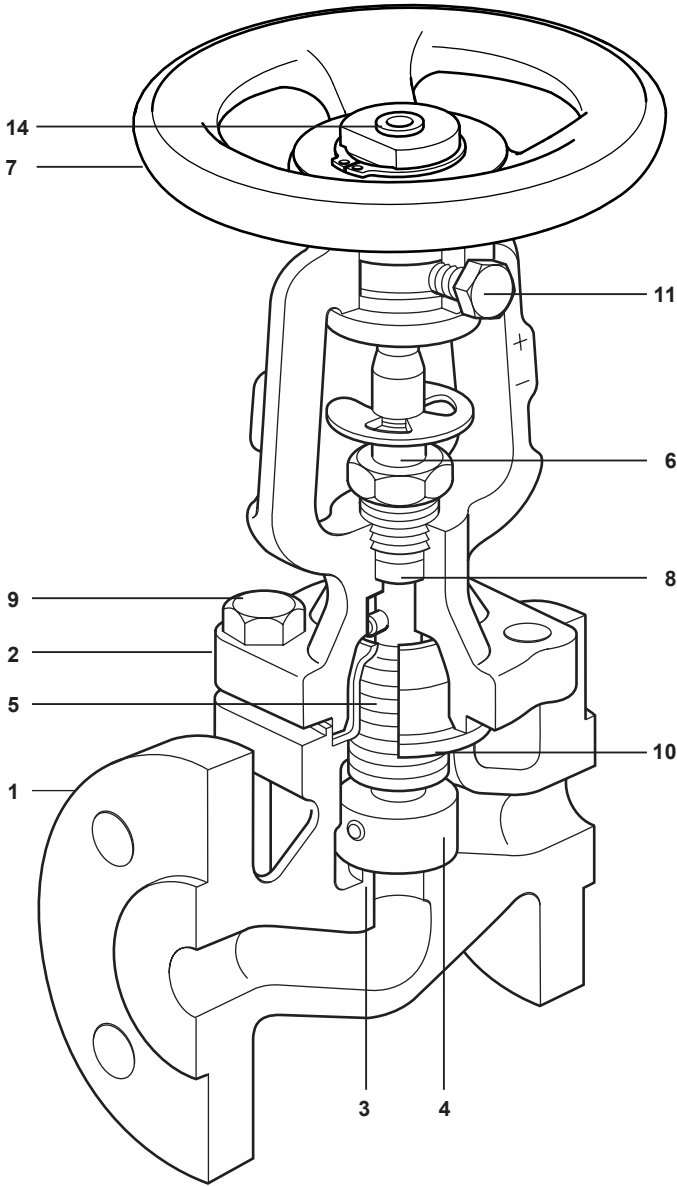

Optional balancing disc assembly

| | | | |
|------------|-------------------|-------|-------------|
| | 25 bar ΔP | DN125 | |
| Used above | 17 bar ΔP | DN150 | 6" |
| | 10 bar ΔP | DN200 | 8" |
| | 6 bar ΔP | DN250 | (BSA2 only) |



Optional soft sealing disc

Across the size range there are three hand wheel retention methods

- DN15 - DN32** have a 'D' drive hand wheel retained by a 'D' washer and circlip.
- DN40 - DN80** have a 'D' drive hand wheel retained by a top nut.
- DN100 - DN250** have a screwed hand wheel retained by a top nut.

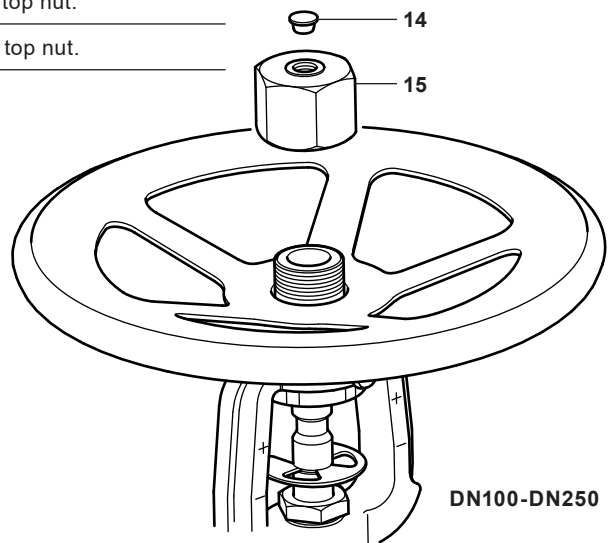
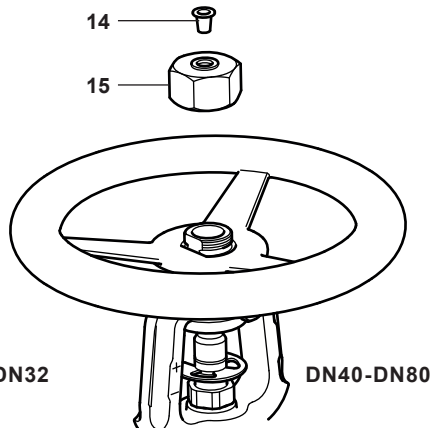
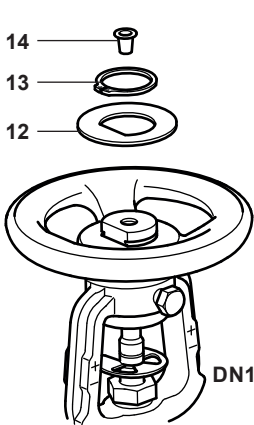

Materials for the BSA6T and BSA64T

| No. | Part | BSA6T | BSA64T |
|-----|--------------------|--|---|
| 1 | Body | Stainless steel EN 10213 1.4408 or ASTM A351 CF8M | Stainless steel EN 10213 1.4408 or ASTM A351 CF8M |
| 2 | Bonnet | Stainless steel EN 10213 1.4581 | Carbon steel DN15 - DN80 DIN 117243 C22.8 Carbon steel DN100 10619+N (GSC 25N) |
| 3 | Seat | Stainless steel EN 10213 1.4408 or ASTM A351 CF8M | |
| 4 | Disc | DN15 - DN40 | Stainless steel EN 10088 1.4571 |
| | | DN50 - DN100 | Stainless steel EN 100222 1.4571 |
| 5 | Bellows | Stainless steel DIN 17440 1.4571 | |
| 6 | Stem | Stainless steel EN 10088 1.4571 | |
| 7 | Handwheel | Pressed steel BS 1449 CR4 | |
| 8 | Stem packing | Graphite | |
| 9 | Bonnet studs | Stainless steel A4-70 | |
| | Bonnet nuts | Stainless steel A4 | |
| 10 | Body/bonnet gasket | Graphite laminated with stainless steel insert | |
| 11 | Locking screw | DN15 - DN80 | Steel M8 x 14 mm A2-70 |
| | | DN100 | Steel M8 x 20 mm A2-70 |

Stroke limiter for throttling versions

The handwheel nut on the **BSA6T** and **BSA64T** has a threaded hole for provision of a stroke limiter. Customer to supply standard nuts and bolts as indicated in the table below.

| Size | Hexagon bolt |
|------------|--------------|
| DN15- DN80 | M8 x 50 mm |
| DN100 | M12 x 75 mm |

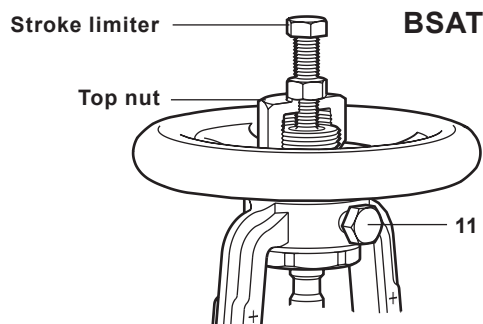

BSAT

DN15-DN32 shown

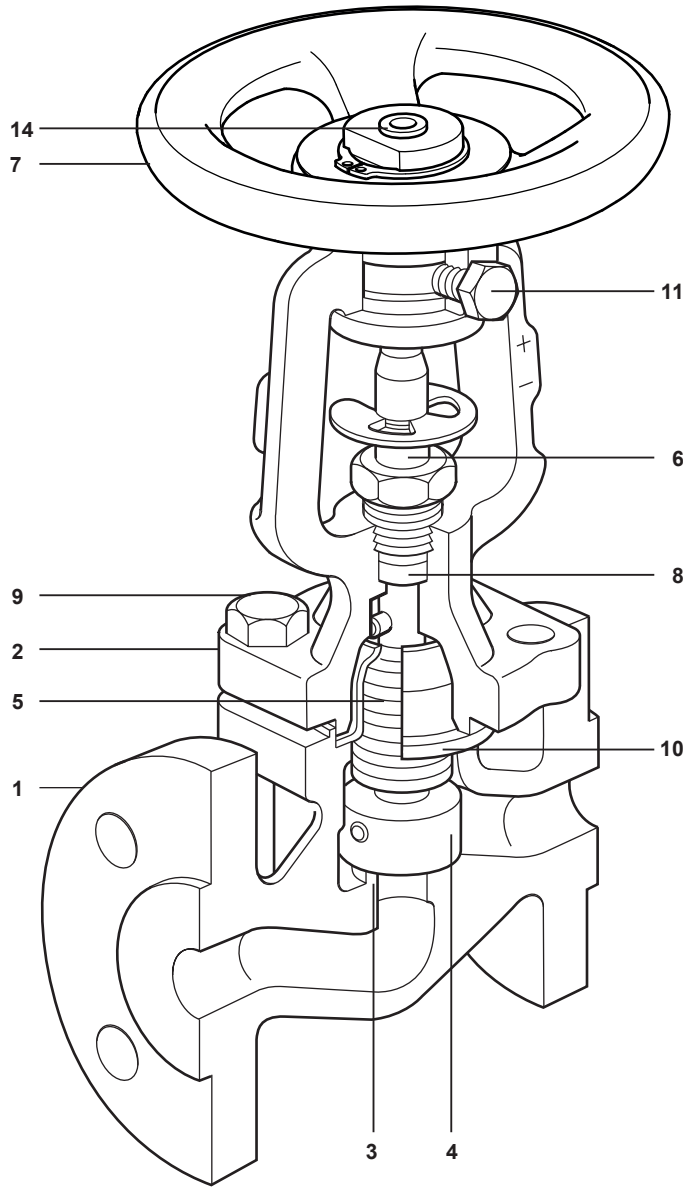

Across the size range there are three hand wheel retention methods

| | |
|-------------|---|
| DN15 - DN32 | have a 'D' drive hand wheel retained by a 'D' washer and circlip. |
| DN40 - DN80 | have a 'D' drive hand wheel retained by a top nut. |
| DN100 | have a screwed hand wheel retained by a top nut. |

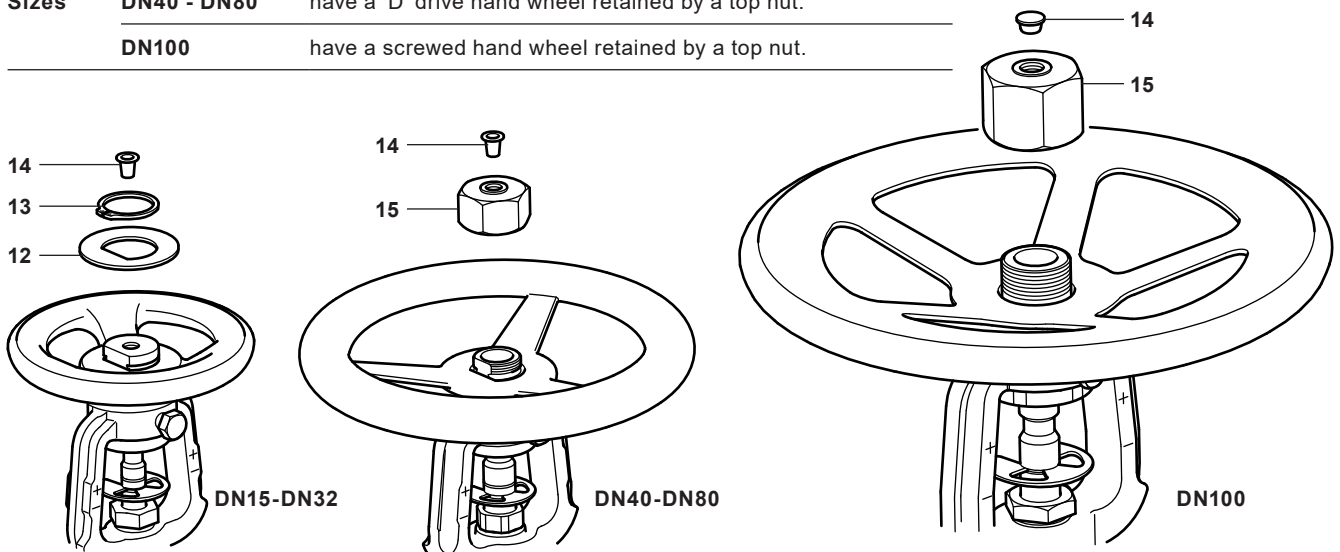

Product limitations

BSA1T and BSA1

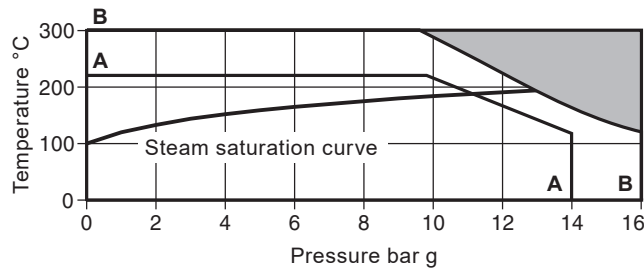

A - A Flanged JIS/KS 10K
B - B Flanged PN16

| Body design conditions | | PN16 | JIS/KS 10K |
|---|--|------------|------------|
| PMA | Maximum allowable pressure | 16 bar g | 14 bar g |
| TMA | Maximum allowable temperature | 300 °C | 220 °C |
| PMO | Maximum operating pressure for saturated steam service | 12.9 bar g | 11 bar g |
| TMO | Maximum operating temperature | | |
| | Soft seat | 230 °C | 220 °C |
| | Metal seat | 300 °C | 220 °C |
| Minimum operating temperature | | -10 °C | -10 °C |
| Designed for a maximum cold hydraulic test pressure of: | | 24 bar g | 20 bar g |

BSA2T and BSA2

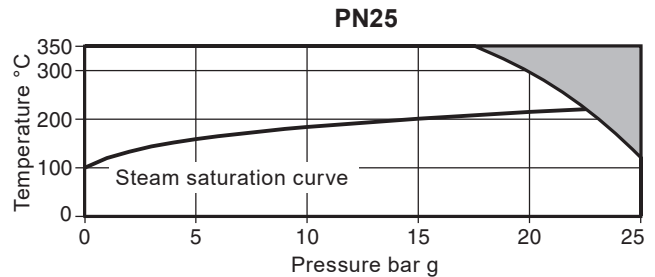
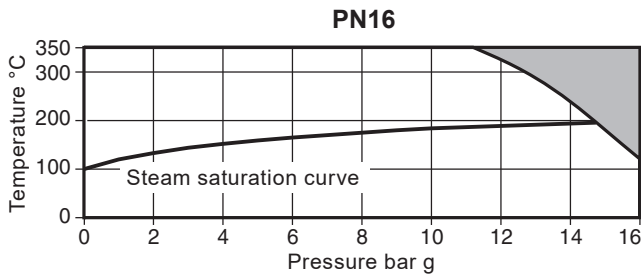

| Body design conditions | | PN16 | PN25 |
|---|--|------------|------------|
| PMA | Maximum allowable pressure | 16 bar g | 25 bar g |
| TMA | Maximum allowable temperature | 350 °C | 350 °C |
| PMO | Maximum operating pressure for saturated steam service | 14.7 bar g | 22.3 bar g |
| TMO | Maximum operating temperature | | |
| | Soft seat | 230 °C | 230 °C |
| | Metal seat | 350 °C | 350 °C |
| Minimum operating temperature | | -10 °C | -10 °C |
| Designed for a maximum cold hydraulic test pressure of: | | 24 bar g | 38 bar g |

Key

 The product **must not** be used in this region.

Note: Δ PMX Maximum differential pressure is limited to the PMO.

Maximum permissible differential pressure in throttling function:

| | |
|---------------|---------|
| DN15 - DN80 | 2.0 bar |
| DN100 - DN125 | 1.5 bar |
| DN150 | 1.0 bar |
| DN200 - DN250 | 0.8 bar |

BSA3T and BSA3 (DIN)

PN25, DN200

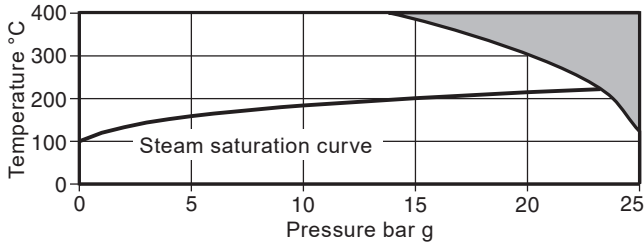

PN40, DN15 - DN150

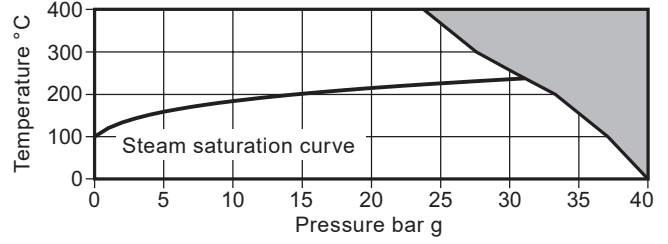

| Body design conditions | | PN25, DN200 | PN40, DN15 - DN150 |
|---|--|-------------|--------------------|
| PMA | Maximum allowable pressure | 25 bar g | 40 bar g |
| TMA | Maximum allowable temperature | 400 °C | 400 °C |
| PMO | Maximum operating pressure for saturated steam service | 23.2 bar g | * 30.4 bar g |
| TMO | Maximum operating temperature | Soft seat | 230 °C |
| | | Metal seat | 400 °C |
| Minimum operating temperature | | -10 °C | -10 °C |
| Designed for a maximum cold hydraulic test pressure of: | | 38 bar g | 60 bar g |

* Maximum operating pressure is limited to 27 bar g for the soft seat version only

BSA3T and BSA3 (ASME)

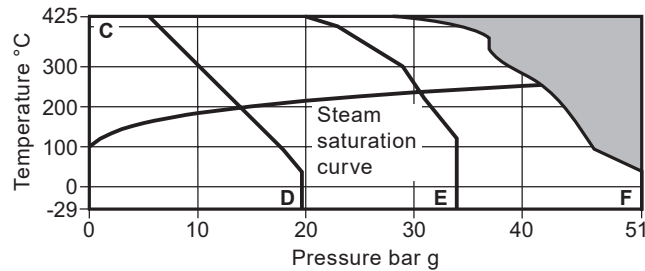

C - D Flanged ASME 150
C - E Flanged JIS/KS 20K
C - F Flanged ASME 300

| Body design conditions | | ASME 150 | ASME 300 | JIS/KS 20K |
|---|--|------------|-------------|-------------|
| PMA | Maximum allowable pressure | 19.6 bar g | 51 bar g | 34 bar g |
| TMA | Maximum allowable temperature | 425 °C | 425 °C | 425 °C |
| PMO | Maximum operating pressure for saturated steam service | 14 bar g | *41.6 bar g | *30.7 bar g |
| TMO | Maximum operating temperature | Soft seat | 230 °C | 230 °C |
| | | Metal seat | 425 °C | 425 °C |
| Minimum operating temperature | | -29 °C | -29 °C | 0 °C |
| Designed for a maximum cold hydraulic test pressure of: | | 31 bar g | 77 bar g | 50 bar g |

* Maximum operating pressure is limited to 27 bar g for the soft seat version only

Key

The product **must not** be used in this region.

Note: ΔPMX Maximum differential pressure is limited to the PMO.

Maximum permissible differential pressure in throttling function:

| | |
|---------------|---------|
| DN15 - DN80 | 2.0 bar |
| DN100 - DN125 | 1.5 bar |
| DN150 | 1.0 bar |
| DN200 | 0.8 bar |

Product limitations

BSA6T and BSA64

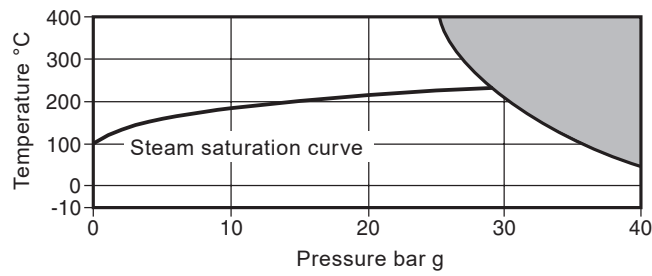

| | | |
|---|--|------------------------------------|
| Body design conditions | | PN40 |
| PMA | Maximum allowable pressure | 40 bar g @ 50 °C |
| TMA | Maximum allowable temperature | 400 °C @ 25 bar g |
| Minimum allowable temperature | | -10 °C |
| PMO | Maximum operating pressure for saturated steam service | Metal seat 29.8 bar g @ 236 °C |
| | | Soft seat 27.0 bar g @ 230 °C |
| TMO | Maximum operating temperature | Metal seat 400 °C @ 25.6 bar g |
| | | Soft seat 230 °C @ 27.0 bar g |
| Minimum operating temperature | | -10 °C |
| | | On/off function Limited to the PMO |
| ΔPMX | Maximum differential pressure | DN15 - DN80 2 bar |
| | | DN100 1.5 bar |
| Designed for a maximum cold hydraulic test pressure of: | | 60 bar g |

Key

 The product **must not** be used in this region.

Note: ΔPMX Maximum differential pressure is limited to the PMO.

Maximum permissible differential pressure in throttling function:

| | |
|-------------|---------|
| DN15 - DN80 | 2.0 bar |
| DN100 | 1.5 bar |

Safety information, installation and maintenance

For full details see the Installation and Maintenance Instructions (IM-P137-02) supplied with the product.

Installation note

Install in the direction of flow given by the arrow on the body with the handwheel in a suitable position.

Disposal

These products are recyclable. No ecological hazard is anticipated with the disposal of these products, providing due care is taken.

How to order

Example: 1 off DN25 Spirax Sarco type BSA2T bellows sealed stop valve, flanged PN16 or PN25.

Note: Should the differential pressure exceed those listed against the respective sizes in the table below, then please ensure balancing discs are specified for use in the valves (see page 7).

| Size | DN125 | DN150 | DN200 | DN250 |
|-----------------------------|-------|-------|-------|-------|
| Differential pressure (bar) | 25 | 17 | 10 | 6 |

Spare parts

The spare parts are shown in heavy outline. Parts drawn in a grey line are not supplied as spares.

Available spares

| | |
|---|---------------|
| Body/bonnet gasket and stem packing | 10, 8 (2 off) |
| Stem and bellows assembly (state if BSAT or BSA) | 5, 6, 8, 10 |
| Disc (and optional disc where fitted) - state full description of the valve | 4, 8, 10 |
| Handwheel | 7 |

How to order spares

Please note: for customer convenience spares are supplied in kits to ensure all the appropriate replacement parts are supplied to carry out a specific maintenance task. e.g. when a stem/bellows assembly is ordered, parts (10), (8) and (6, 5) will be included in the kit.

Always order spares by using the description given in 'Available spares' and state the size and type of stop valve.

Example: 1 - Body/bonnet gasket and stem packing for a DN15 Spirax Sarco BSA2T PN16 bellows sealed stop valve.

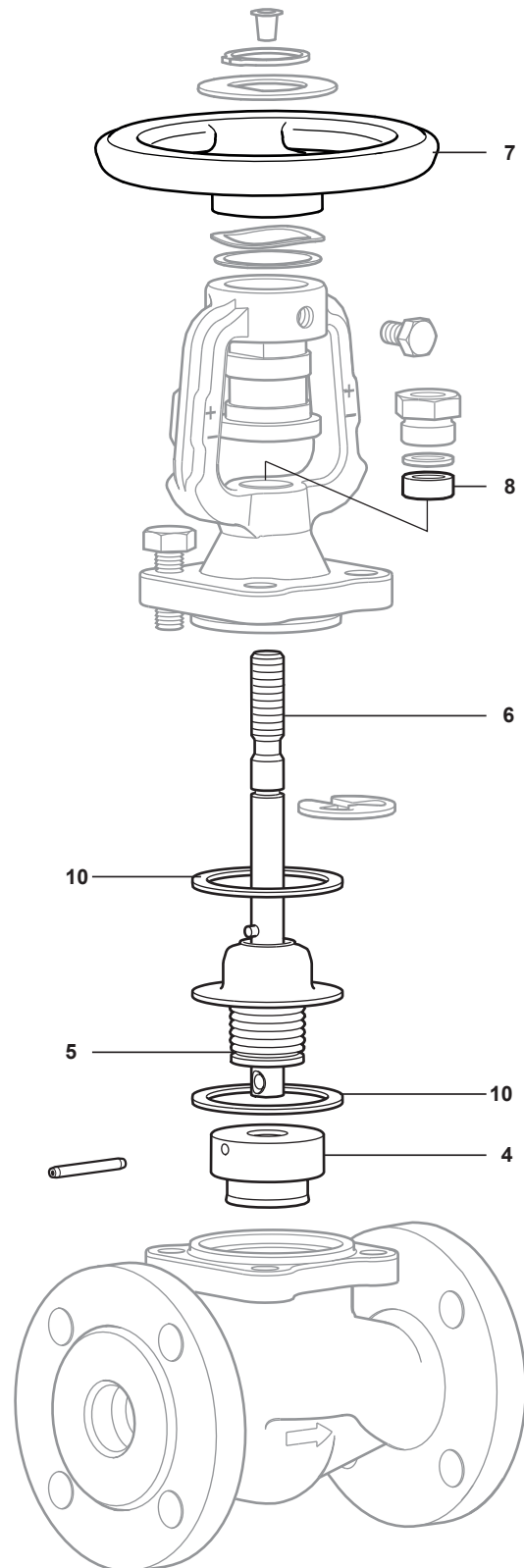

DN15-DN32 shown