



BRV2S and BRV2B SG Iron Pressure Reducing Valves

Description

The BRV2S and BRV2B are direct acting pressure reducing valves designed for applications using steam or gases such as compressed air. This range of pressure reducing valves have SG iron bodies and are available with screwed or flanged connections.

Available types

| | | |
|---------------|-------------------------|---|
| BRV2S | Stainless steel bellows | |
| BRV2B | Phosphor bronze bellows | |
| BRV2SP | Stainless steel bellows | With external pressure sensing connection |
| BRV2BP | Phosphor bronze bellows | |

BRV2 pressure reducing valves are supplied with one of three colour coded springs which are identified by the disc (18) located on the adjustment handwheel.

Note: Where control spring ranges overlap always use the lower range to give better control:

| | | |
|---------------|----------------------------------|--|
| Grey | For downstream pressure control: | 0.14 to 1.7 bar g (2 to 25 psi g) |
| Green | For downstream pressure control: | 1.40 to 4.0 bar g (20 to 58 psi g) |
| Orange | For downstream pressure control: | 3.50 to 8.6 bar g (51 to 125 psi g) |

Standards

This product fully complies with the requirements of the Pressure Equipment Directive (PED).

Certification

This product is available with a manufacturers' Typical Test Report.

Note: All certification/inspection requirements must be stated at the time of order placement.

Sizes and pipe connections

½", ¾" and 1" screwed BSP (BS 21 Rp) or NPT.
DN15, DN20 and DN25 flanged EN 1092 PN25.

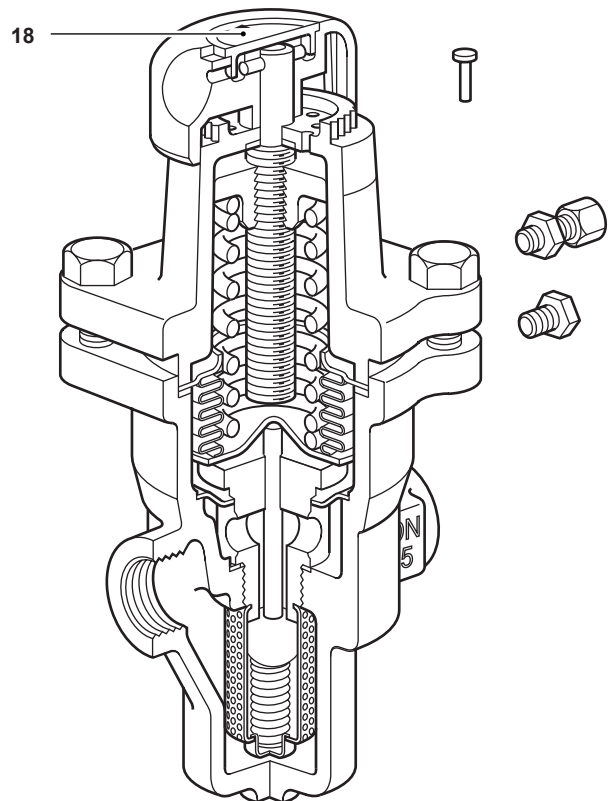

Pressure/temperature limits

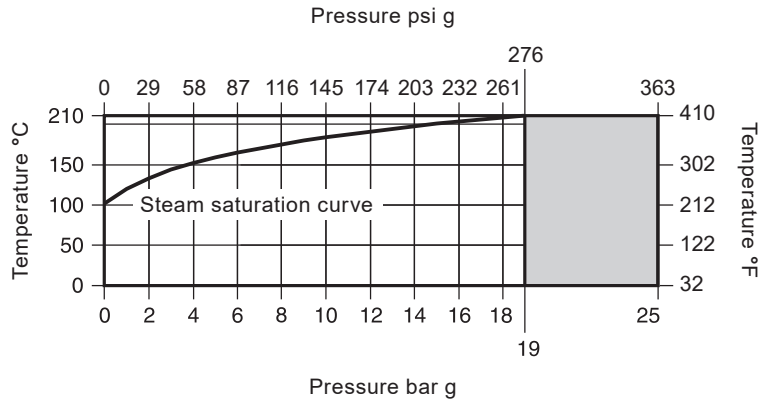

The product **must not** be used in this region.

| | | |
|--|-------------------|----------------------|
| Body design conditions | | PN25 |
| Maximum design pressure | 25 bar g @ 120 °C | (363 psi g @ 248 °F) |
| Maximum design temperature | 210 °C @ 19 bar g | (410 °F @ 276 psi g) |
| Minimum allowable temperature | -10 °C | (14 °F) |
| Maximum operating pressure for saturated steam service | 17 bar g @ 207 °C | (247 psi g @ 405 °F) |
| Maximum operating temperature | 207 °C @ 17 bar g | (405 °F @ 247 psi g) |
| Minimum operating temperature | 0 °C | (32 °F) |
| Note: For lower operating temperatures consult Spirax Sarco | | |
| Maximum downstream reduced pressure | 8.6 bar g | (125 psi g) |
| Maximum differential pressure | 17 bar | (247 psi) |
| Maximum recommended turndown ratio | | 10:1 at maximum flow |
| Designed for a maximum cold hydraulic test pressure of: | 38 bar g | (551 psi g) |
| Note: With internals fitted, test pressure must not exceed: | 19 bar g | (276 psi g) |

Materials

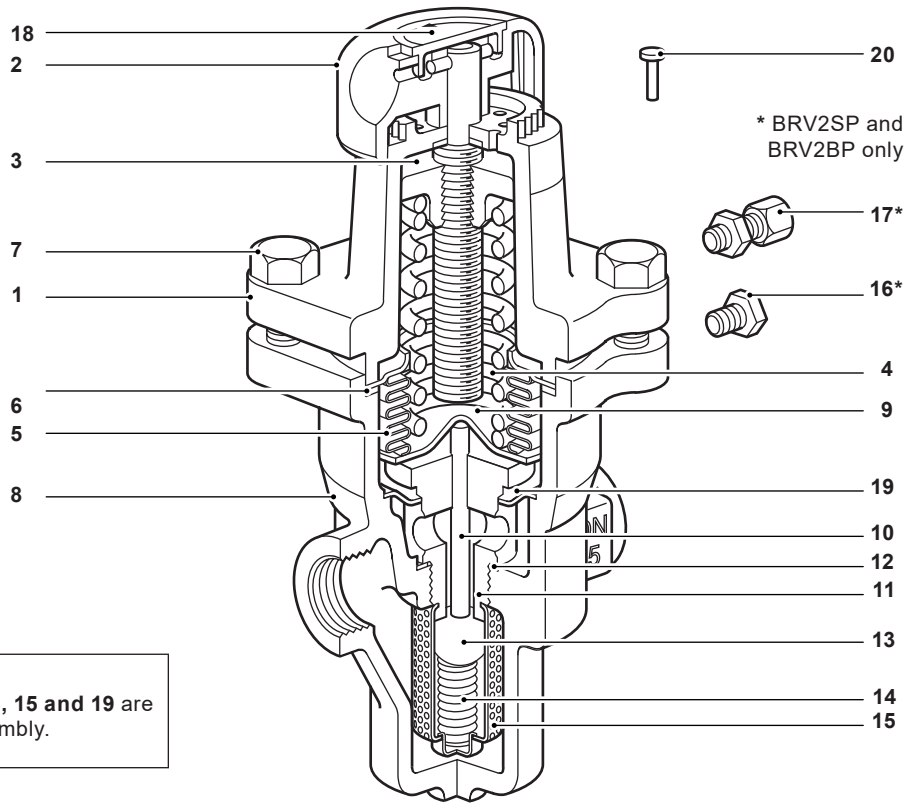

| No. | Part | Materials | |
|-----|----------------------------|--|-------------------------|
| 1 | Spring housing | Aluminium epoxy coated | LM 24 |
| 2 | Adjustment handwheel | Polypropylene | |
| 3 | Top spring plate | Cast iron | DIN 1691 GG 20 |
| 4 | Pressure adjustment spring | Silicon chrome spring steel | BS 2803 685 A55 Range 2 |
| 5 | Bellows assembly | Stainless steel | 316Ti/316L |
| | | Phosphor bronze/brass | BS 2872 Cz 122 |
| 6 | Bellows assembly gasket | Stainless steel reinforced exfoliated graphite | |
| 7 | Hex. bolt (M8 x 25 mm) | Steel zinc plated | BS 3692 Gr. 8.8 |
| 8 | Body | SG iron | DIN 1693 GGG 40.3 |
| 10 | Pushrod | Stainless steel | ASTM A276 316L |
| 11 | Valve seat | Stainless steel | BS 970 431 S29 |
| 12 | Valve seat gasket | Stainless steel | BS 1449 316 S11 |
| 13 | Valve | Stainless steel | AISI 420 |
| 14 | Valve return spring | Stainless steel | BS 20056 316 S42 |
| 15 | Strainer screen | Stainless steel | BS 1449 316 SH |
| 16 | Blanking plug | Stainless steel | BS 970 431 S29 |
| 17 | Compression fitting | Brass | |
| 18 | Spring range ID disc | Polypropylene | |
| 19 | Bulkhead plate | Stainless steel | 316L |
| 20 | Tamper-proof pin | Mild steel copper plated | |

Capacities for safety valve sizing

Full lift capacities for safety valve sizing purposes:

| Size | DN15 (½") | DN20 (¾") | DN25 (1") | For conversions: |
|------|-----------|-----------|-----------|--|
| Kvs | 1.5 | 2.5 | 3.0 | Cv (UK) = Kv x 0.963 Cv (US) = Kv x 1.156 |

Steam and compressed air capacities

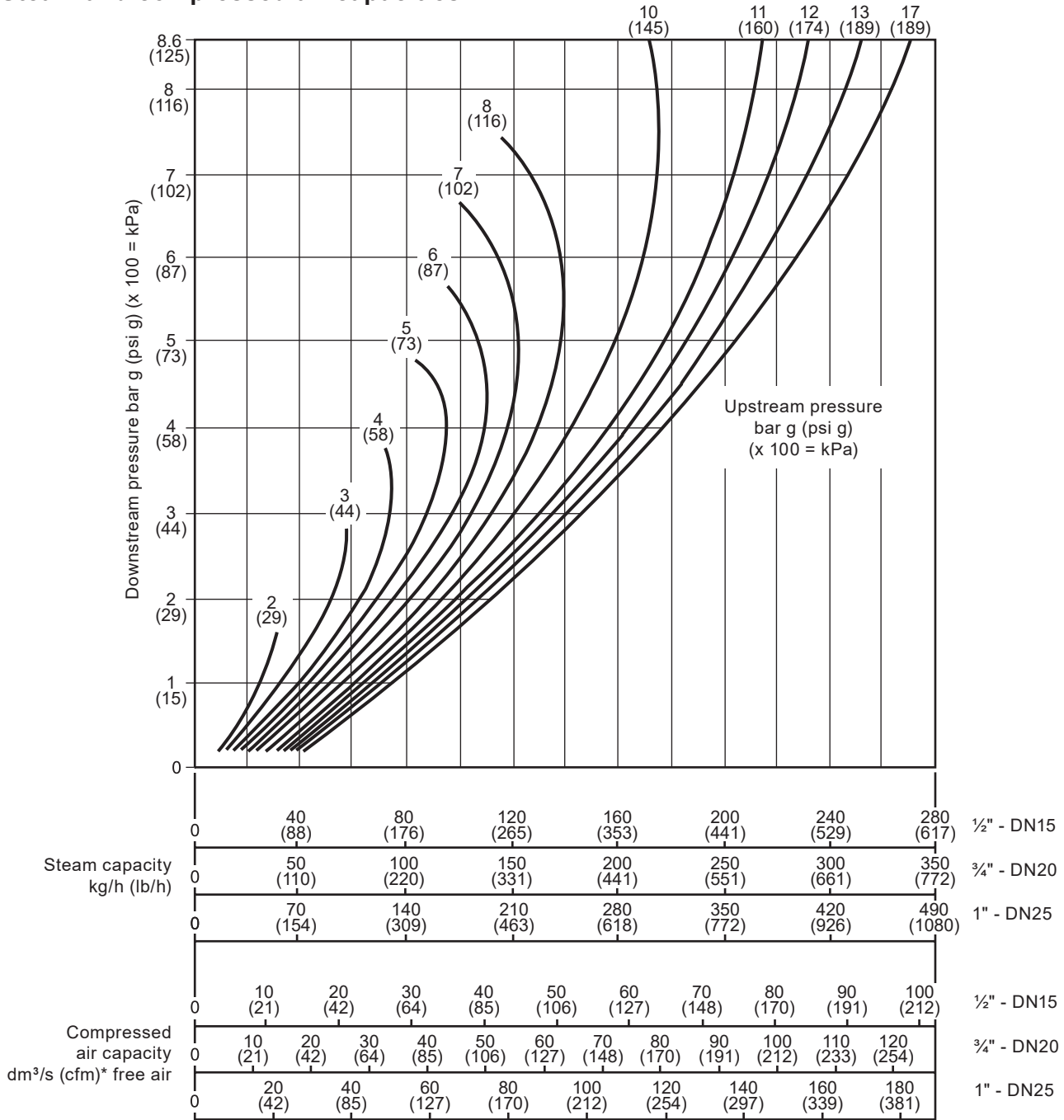

* dm³/s = l/s, 1 l/s \approx 2 c.f.m.

How to use the chart

The curved lines labelled 2, 3, 4, 5 etc., represent upstream pressures. Downstream pressures are read along the vertical line on the left hand side of the chart.

How to use the chart is best described by an example:-

Required, a pressure reducing valve to pass 120 kg/h reducing from 8 to 6 bar. From the downstream pressure of 6 bar on the left hand side of the chart extend out horizontally until the line meets the curved 8 bar upstream line. At this point read vertically downwards where it will be seen that a ½" BRV2 will be required.

Dimensions/weights (approximate) in mm (in) and kg (lb)

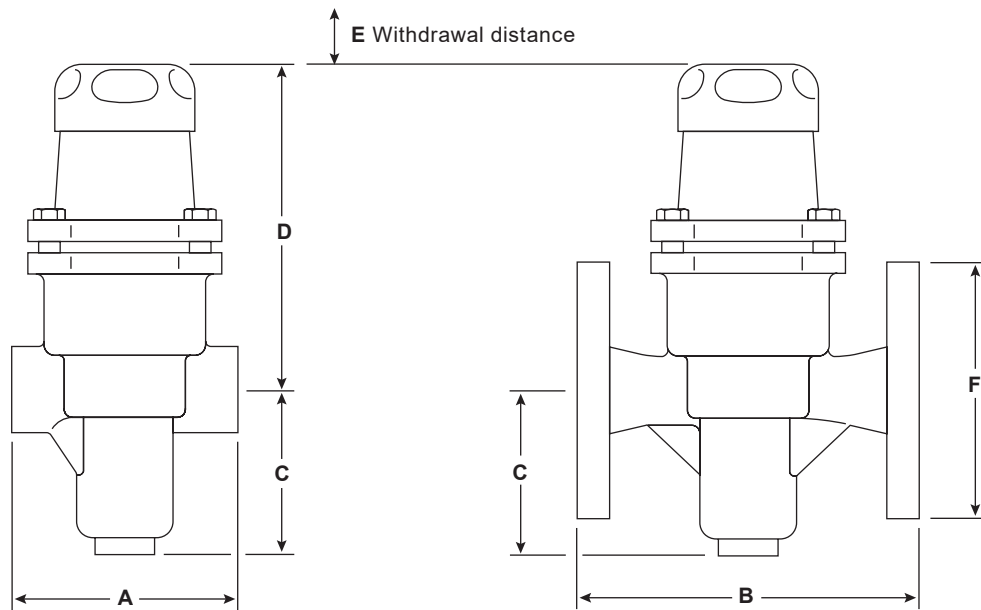

| Size | A | B | C | D | E | F | Weight | |
|-------------|--------------|---------------|-------------|--------------|--------------|---------------|----------------|----------------|
| | | | | | | | Scr | Flg |
| DN15 - 1/2" | 83 (3.3) | 150 (5.91) | 60 (2.4) | 130 (5.1) | 25 (0.98) | 97 (3.8) | 1.60 (3.53) | 3.90 (8.60) |
| DN20 - 3/4" | 96 (3.8) | | | | | 107 (4.21) | 1.70 (3.75) | 4.25 (9.37) |
| DN25 - 1" | 108 (4.3) | | | | | 117 (4.61) | 1.95 (4.30) | 4.65 (10.3) |

Safety information, installation and maintenance

For full details see the Installation and Maintenance Instructions (IM-P045-10) supplied with the product.

Installation note:

The valve should be installed in a horizontal pipeline with the direction of flow as indicated by the arrow on the valve body.

BRV2SP and BRV2BP: When external pressure sensing is used, remove the blanking plug (16) and fit the 1/8" /6 mm O/D compression fitting (17 supplied). The other end of the 6 mm sensing pipe should be connected into the downstream pipework at least 1 m (3.28 ft) downstream from the valve.

How to order

Example: 1 off Spirax Sarco DN15 BRV2S pressure reducing valve with SG iron body flanged EN 1092 PN25, stainless steel bellows and fitted with an orange spring for downstream pressure control of 3.5 to 8.6 bar g.

Spare parts

The spare parts available are shown in solid outline.
Parts drawn in a grey line are not supplied as spares.

Available spares

| | | | |
|--|--------------|---|---------------|
| Pressure adjustment spring * | Grey | 0.14 to 1.7 bar g (2.03 to 24.7 psi g) | 4, 18 |
| | Green | 1.40 to 4.0 bar g (20.3 to 58.0 psi g) | 4, 18 |
| | Orange | 3.50 to 8.6 bar g (50.8 to 125 psi g) | 4, 18 |
| Bellows assembly * | specify type | Stainless steel or phosphor bronze | 5, 6 |
| Spring housing hex. bolts (set of 4) * | | | 7 |
| Valve and seat assembly | | | 6, 11, 12, 19 |
| Gasket set * | | | 6, 12 |

* Common to all sizes.



How to order spares

Always order spares by using the description given in the column headed 'Available spares' and state the size, type and pressure range of the reducing valve.

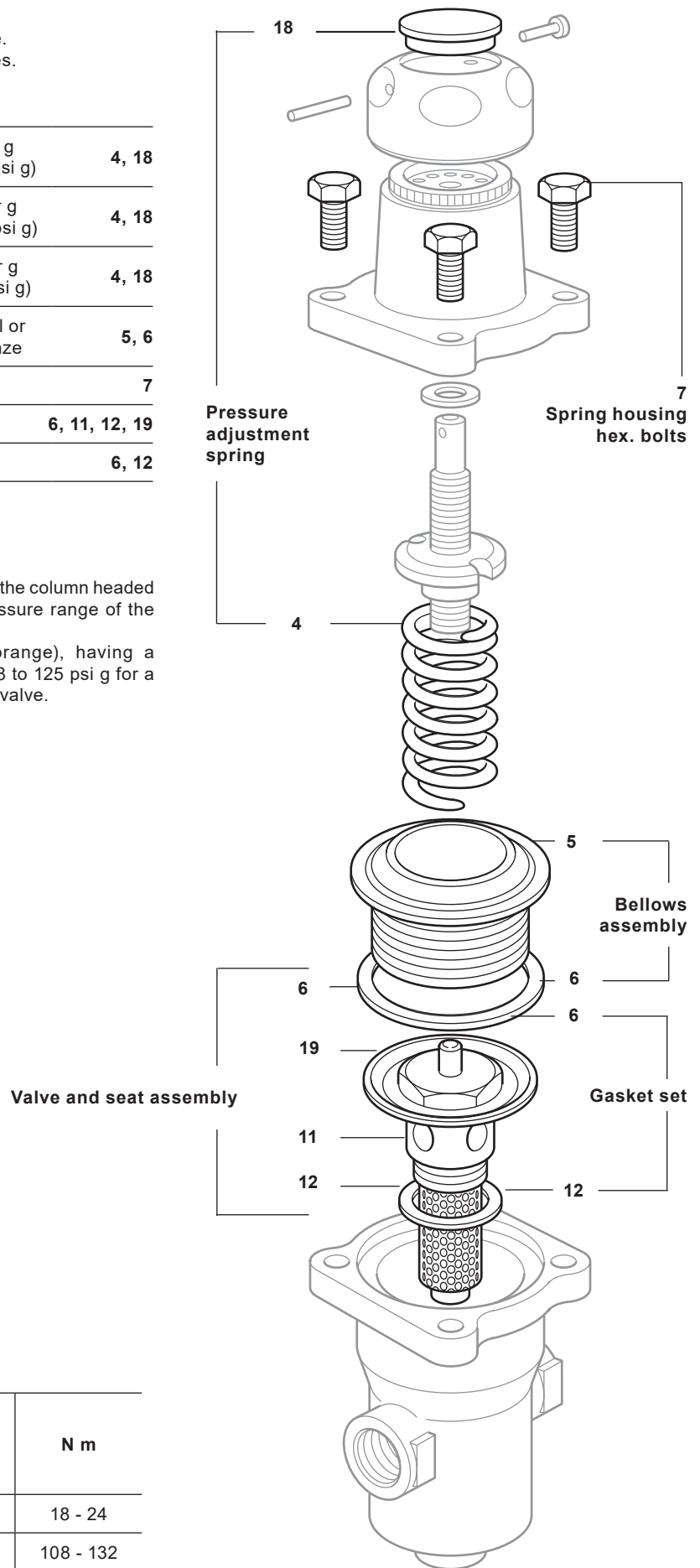
Example: 1 off Pressure adjustment spring (orange), having a downstream pressure range of 3.5 to 8.6 bar g 50.8 to 125 psi g for a Spirax Sarco DN15 (½") BRV2S pressure reducing valve.



Recommended tightening torques

| Item | Part |  or  | mm | N m |
|------|------------|--|---------|-----------|
| 7 | Hex. bolts | | M8 x 25 | 18 - 24 |
| 11 | Valve seat | | 32 A/F | 108 - 132 |