

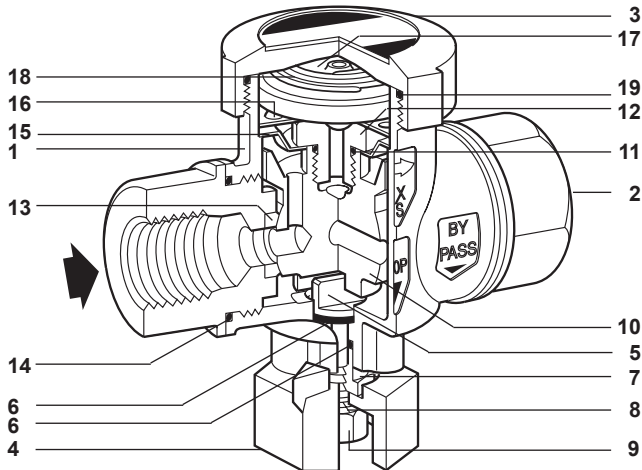

TI-P126-03
 ST Issue 6

BPT13T and BPT13TGX Thermostatic Steam Traps

BPT13T



BPT13TGX
 with view glass

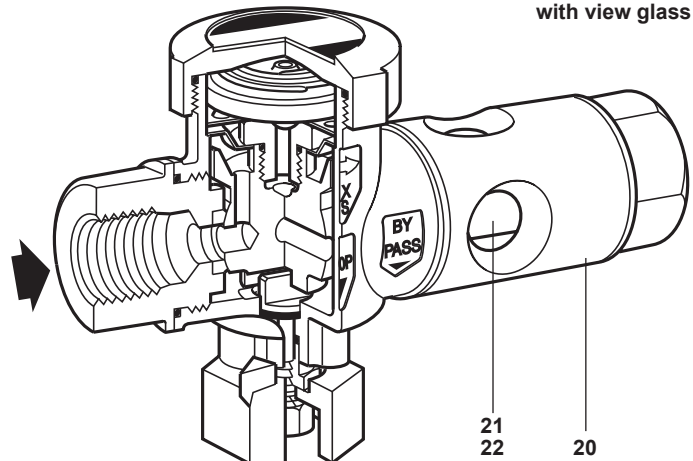

Description

The BPT13T is a brass bodied maintainable balanced pressure steam trap with horizontal in-line connections. It has a unique bypass and stop valve feature built into the trap which simplifies and reduces the cost of installation. The bypass can be used simply to handle high start-up loads or to avoid debris collecting in the steam trap, on the commissioning of new systems. The BPT13TGX has an integral sight tube for indication of operation.

Note: When placing an order always state capsule fill.

Capsule fill and operation

Standard capsules are marked with the letter 'STD' for operation at approximately 10°C below steam saturation temperature.

Optionally the capsule can be supplied for sub-cooled 'SUB' operation at approximately 22°C below steam saturation temperature or a 'NTS' fill capsule for near-to-steam operation at approximately 4°C below steam saturation temperature.

Sizes and pipe connections

½", ¾" and 1" screwed BSP

Pressure / temperature limits (ISO 6552)

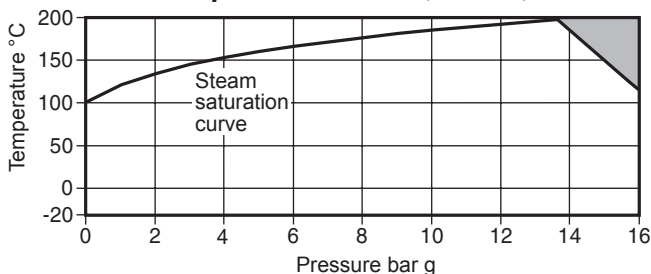

The product **must not** be used in this region.

Body design conditions		PN16
PMA	Maximum allowable pressure	16 bar g @ 120°C
TMA	Maximum allowable temperature	200°C @ 7 bar g
Minimum allowable temperature		-20°C
PMO	Maximum operating pressure	13 bar g @ 220°C
TMO	Maximum operating temperature	200°C @ 7 bar g
Minimum operating temperature		0°C

Note: For lower operating temperatures consult Spirax Sarco
 Designed for a maximum cold hydraulic test pressure of 24 bar g

Materials

No.	Part	Material	
1	Body	Brass	BS EN 12165 CW 617N
2	End connection	Brass	BS EN 12165 CW 617N
3	Cap	Brass	BS EN 12165 CW 617N
4	Actuator	Stainless steel	BS 3146 Pt2 ANC 4B
5	Spindle	Stainless steel	BS 970 431 S29
6	Stem seal	25% carbon filled PTFE	
7	Gland nut	Stainless steel	BS 970 303 S31
8	Spring washer	Stainless steel	BS 6105 Gr. A4
9	Lock-nut	Stainless steel	ISO 3506-2: A2-70
10	Ball plug	Brass (ELNP Finish)	BS 2874 CZ 121
11	Seat 'O' ring	Synthetic rubber high fluorine fluorocarbon	
12	Valve seat	Stainless steel	BS 970 431 S29
13	Main seal	25% carbon filled PTFE	
14	End connection 'O' ring	Synthetic rubber high fluorine fluorocarbon	
15	Screen	Stainless steel	ASTMA240 TP 304
16	Spacer plate	Stainless steel	BS 1449 304 S16
17	Capsule	Stainless steel	
18	Spring	Stainless steel	BS 2056 302 S26
19	Cap 'O' ring	Synthetic rubber high fluorine fluorocarbon	
20	Sight tube housing	Brass	BS 2874 CZ 121
21	Sight tube gasket	Virgin PTF E/Fluorocarbon	
22	Sight tube	Borosilicate glass	

First for Steam Solutions

Dimensions / weights (approximate) in mm and kg

Size	A	B	B1	C	D	E	Weight	
							BPT13T	BPT13GX
½"	92	97	133	45	50	55	1.1	1.35
¾"	92	117	153	45	50	55	1.2	1.45
1"	92	127	163	45	50	55	1.5	1.75

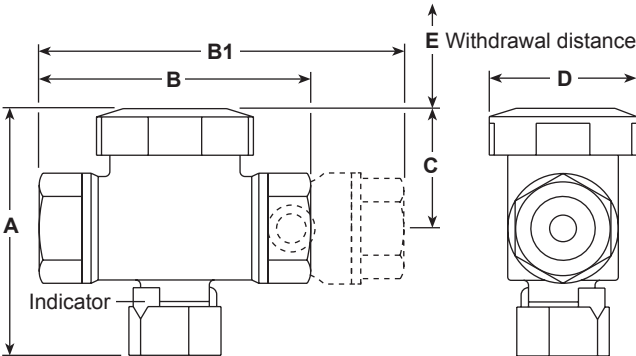

Installation

The trap is designed for installation with the capsule in a horizontal plane and the cap at the top, preferably with a drop leg immediately preceding the trap. See IM-P126-05 for full installation details.

Warning:

Under certain conditions corrosive elements in condensate can effect the inside face of the sight tube, particularly where caustic alkali and hydrofluoric acid are present. It is recommended that the sight tube is periodically checked for thinning. If there is evidence of thinning or erosion damage then the sight tube should be replaced immediately. Always wear eye protection when viewing the contents of the sight tube.

Reasonable steps should be taken to protect personnel from injury in the unlikely event that the sight tube breaks.

Operation

The trap is supplied in the 'Bypass' position (1). To move it to 'Trap' (2) or 'Stop' (3) position the actuator should be moved until the indicator aligns with the marking on the body.

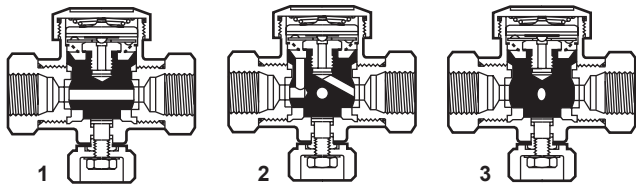

Maintenance

See IM-P126-05 for full maintenance details

Replacement of capsule assembly:

Before any maintenance is undertaken, suitable independent isolation valves should be closed and the trap positioned in the 'bypass' mode. Allow the trap to cool. Remove the cap and lift out the old capsule, spring and spacer plate. Drop in a new spacer plate, capsule and spring. Screw on the cap using a new 'O' ring assembled into the groove in the top of the cap. Always fit a completely new assembly when replacing the capsule.

Recommended tightening torques

Item	Size	or mm	Nm
2 and 20	DN15	32	35 - 40
2 and 20	DN20	36	35 - 40
2 and 20	DN25	46	35 - 40
3	DN15 - 25	50	50 - 60
4	DN15 - 25	30	-
7	DN15 - 25	13	7 - 10
9	DN15 - 25	13	12 - 15
12	DN15 - 25	17	12 - 15

How to order

Example: 1 off ½" Spirax Sarco BPT13 balanced pressure thermostatic steam trap with a capsule marked 'SUB' for sub-cooled operation.

Capacities

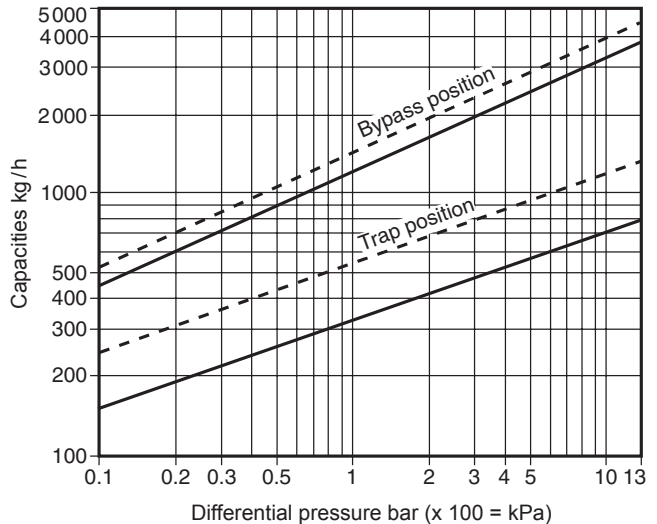

Hot water capacity ——— Cold water capacity - - - -

Spare parts

The spare parts available are shown in heavy outline. Parts drawn in broken line are not supplied as spares.

Available spares

Capsule assembly	16, 17*, 18, 19
Maintenance kit	6 (2 off), 11, 12, 13 (2 off), 14 (2 off), 15, 16, 17*, 18, 19
Sight tube assembly	21 (2 off), 22

*Note: The capsule can be identified from the letter stamped on the name-plate on the cap (e.g. STD, SUB or NTS). A standard capsule (STD) will be supplied, unless specified otherwise on the order.

How to order spares

Always order spares by using the description given in the column headed 'Available spares' and state the size and type of trap.

Example: 1 - Capsule assembly, marked STD, for a Spirax Sarco BPT13T balanced pressure thermostatic steam trap.

