

# spirax sarco

## BBV

# Automatic or Manually Actuated Boiler Blowdown Valves DN15 to DN50

## Description

The BBV is specifically designed for the removal of suspended/deposited solids and water from the bottom of steam boilers. The BBV is available in air-actuated and manual versions. The air-actuated version is supplied with a manual hand lever. The valve is spring-to-close on power failure and the manual version can easily be upgraded to an automatic version.

When used with a Spirax Sarco blowdown controller the automatic version provides timed control of blowdown, ensuring that the recommended blowdown occurs with the minimum of heat loss and avoids duplication and omissions.

The valve can be fitted with a mechanical switchbox. This can be linked to the blowdown controller or a BMS system to indicate when the valve has not closed. An optional ¼" 3-way solenoid valve may be directly mounted on the side of the actuator.

## WARNING:

This product should only be used to purge boiler water containing non-metallic sludge and sediment within the pressure and temperature limits.

For optimum performance, ensure that TDS value is in accordance with the boiler's instructions.

## Principal features:

- Easily upgraded from manual to automatic operation.
- Dedicated self-adjusting and self-cleaning spindle seals.
- Engineered for the specific application of bottom blowdown.
- Flow pressure assists closing.

## Available types of boiler blowdown valve:

Air pneumatically actuated supplied with a manual actuation lever	<b>BBV43 PN/M</b>	Steel body
	<b>BBV63 PN/M</b>	Stainless steel body
	<b>BBV83 PN/M</b>	Alloy steel body
Manually actuated complete with a manual actuation lever	<b>BBV43 M</b>	Steel body
	<b>BBV63 M</b>	Stainless steel body
	<b>BBV83 M</b>	Alloy steel body

**Please note:** All of the 'M' versions can be automated to 'PN/M'.

## Optional extras:

- Automatic bottom blowdown timer controller.
- Mechanical switch (with mounting kit).
- Pneumatic actuator upgrade kit.
- Physical lock kit.
- ¼" 3-way solenoid valve Option

## Standards

This product range fully complies with the requirements of the Pressure Equipment Directive (PED).

## Certification

This product is available with material certification to EN 10204 3.1.

**Note:** All certification/inspection requirements must be stated at the time of order placement.

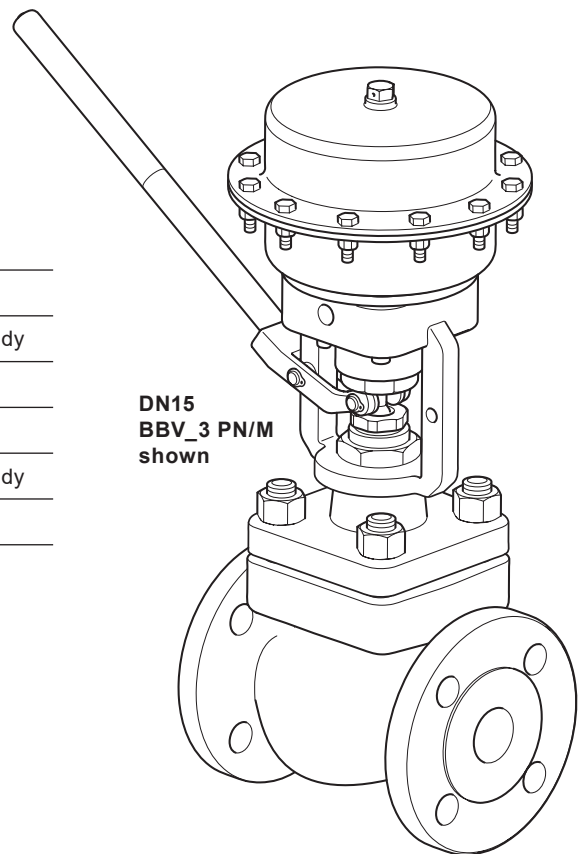

## Size and pipe connections:

DN15, DN20, DN25, DN32, DN40 and DN50

½", ¾", 1", 1¼", 1½", 2"

Flanged EN 1092 PN40, PN63 and PN100

Flanged ASME 300 and ASME 600

### Other available options:

Butt weld

Socket weld

JIS/KS 30 and JIS/KS 40

**For alternative connections** to those stated opposite please contact Spirax Sarco.

## Materials

No.	Part	Material
1	Body	BBV4_ Carbon Steel
		BBV6_ Stainless Steel
		BBV8_ Alloy Steel
2	Plug	Stainless Steel + stellite
3	Seat	Stainless Steel + stellite
4	Seat gasket	Reinforced exfoliated graphite
5	Seat retainer	Stainless Steel
6	Cover	BBV4_ Carbon Steel
		BBV6_ Stainless Steel
		BBV8_ Alloy Steel
7	Packing	BBV__P PTFE
		BBV__H Graphite
8	Cover gasket	Reinforced exfoliated graphite
9	Bonnet nuts	BBV__H Stainless Steel
		BBV6_ Carbon Steel
		Other Carbon Steel
10	Bonnet studs	BBV__H Stainless Steel
		BBV6_ Carbon Steel
		Other Carbon Steel
11	Actuator clamp nut	BBV6_ Stainless Steel
		Other Carbon Steel
12	Gland nut	Stainless Steel
13	Scraper ring	PTFE
14	Yoke	SG Iron
15	Closed plate	Stainless Steel

No.	Part	Material
16	Hex. head screw	Carbon Steel
17	Nut	Carbon Steel
18	Upper housing	Carbon Steel
19	Diaphragm	Reinforced NBR
20	Gasket	Reinforced Graphite
21	Vent plug	Brass
22	Bolt	Carbon Steel
23	Diaphragm plate	Aluminium
24	Spindle	Stainless Steel
25	Lever stem	Stainless Steel
26	Screw	Carbon Steel
27	Seal	Polyurethane
28	Spring	Spring Steel
29	Spring guide	Stainless Steel
30	Connector	Stainless Steel
31	Lever	SG Iron
32	Axis	Stainless Steel
33	Roller	Stainless Steel
34	Spring graphite	Spring Steel
35	Elastic ring	Carbon Steel
36	Elastic ring	Carbon Steel
37	Washer	Carbon Steel
38	O'ring	Viton
39	Spacer	Carbon Steel
40	Washer	Carbon Steel

## K<sub>vs</sub> values

Valve size	DN15	DN20	DN25	DN32	DN40	DN50
Seat diameter (mm)	22			25		
K <sub>vs</sub> values	4.9	7.2	10	18		

For conversion:

$$C_v \text{ (UK)} = K_v \times 0.963$$

$$C_v \text{ (US)} = K_v \times 1.156$$

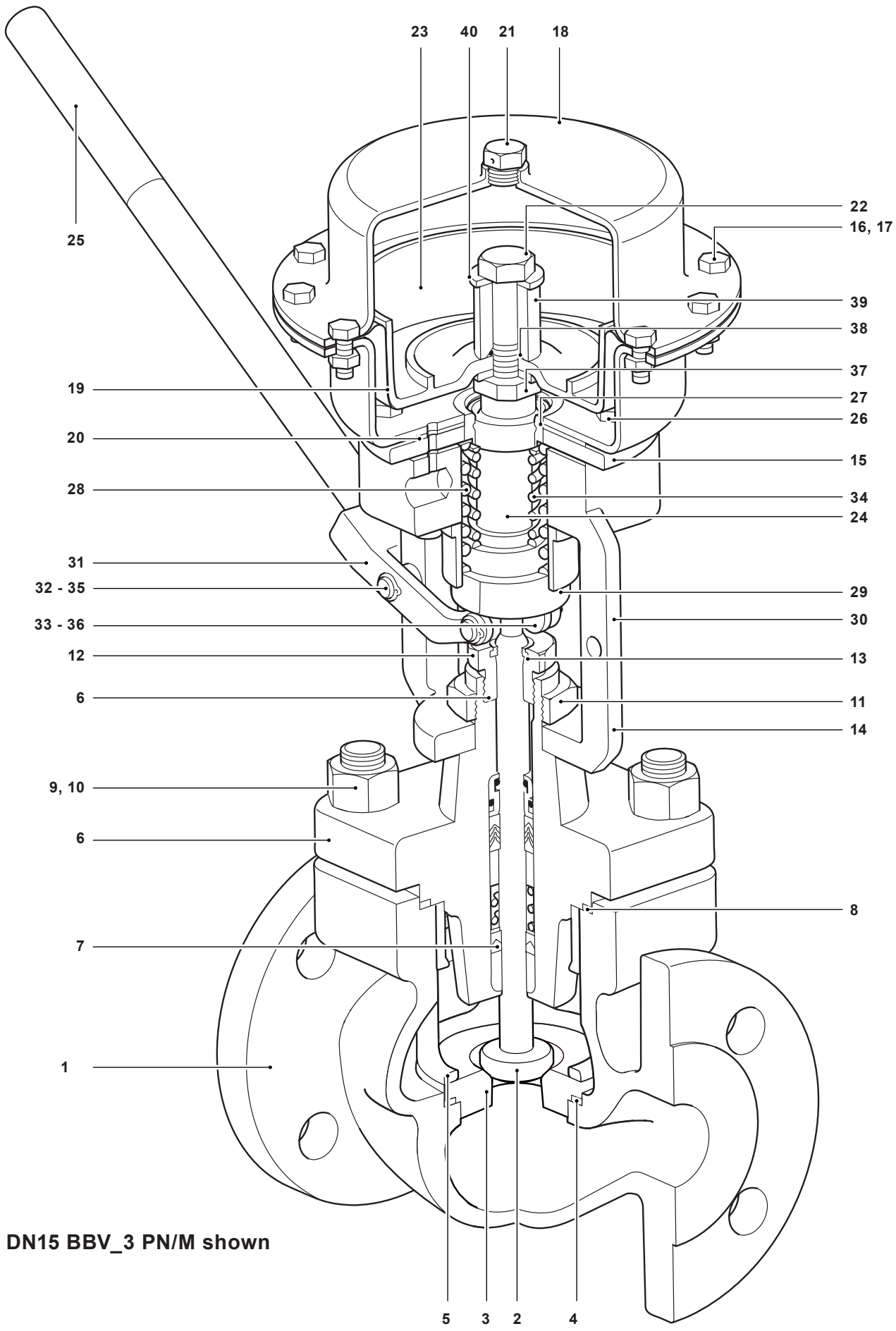

DN15 BBV\_3 PN/M shown

## Minimum air pressure/Differential pressure

Differential pressure ( $\Delta P$ ) across the valve	Minimum air pressure bar g	
	DN15 - DN25	DN32 - DN50
10 bar g	0.7	1.8
15 bar g	0.9	2.6
20 bar g	1.1	3.3
25 bar g	1.2	4.0
30 bar g	1.4	4.7
32 bar g	1.4	5.0
42 bar g	1.7	
63 bar g	2.4	
68 bar g	2.6	
80 bar g	2.9	
100 bar g	3.6	

## Capacities

Size	DN15	DN20	DN25	DN32	DN40	DN50
$K_v$	4.9	7.2	10	18		
	Capacity (m <sup>3</sup> /h)					
0	0.0	0.0	0.0	0.0		
0.5	3.5	5.1	7.1	12.7		
1	4.9	7.2	10.0	18.0		
10	15.5	22.8	31.6	56.9		
20	21.9	32.2	44.7	80.5		
30	26.8	39.4	54.8	98.6		
40	31.0	45.5	63.2	113.8		
50	34.6	50.9	70.7	127.3		
60	38.0	55.8	77.5	139.4		
70	41.0	60.2	83.7	150.6		
80	43.8	64.4	89.4	161.0		
90	46.5	68.3	94.9	170.8		
100	49.0	72.0	100.0	180.0		

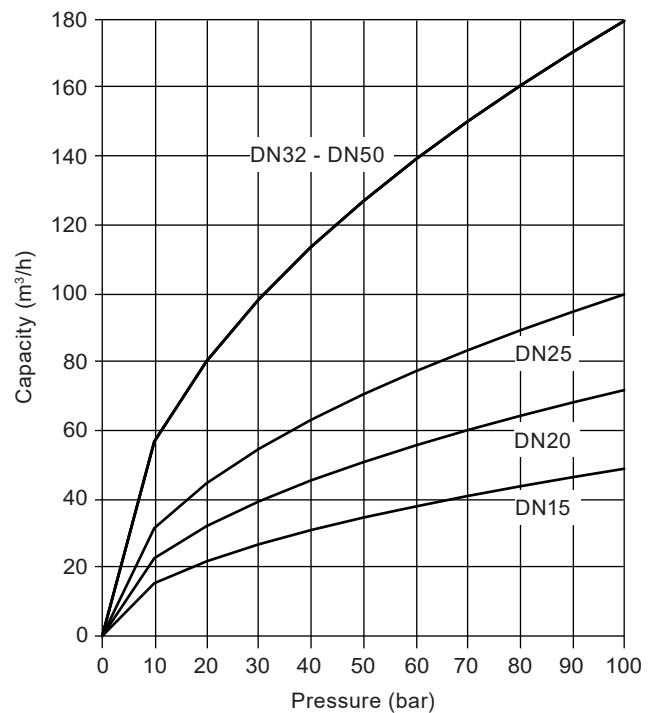

## BBV43 Pressure/temperature limits - EN 1092

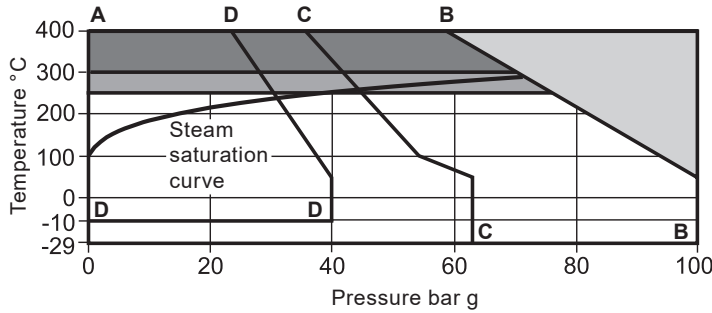

- The product **must not** be used in this region.
- An extended cover is required for use in this region.
- High temperature packing required for use in this region.

### Notes:

1. Where the process fluid temperature is sub-zero and the ambient temperature is below +5 °C, the external moving parts of the valve and actuator must be heat traced to maintain normal operation.
2. When selecting a valve with a bellows scaled bonnet, the pressure/temperature limits of the bellows must be read in conjunction with the valve pressure/temperature limits shown in table below.

	Body design conditions	PN100
	PMA Maximum allowable pressure	100 bar g @ 50 °C
	PMO Maximum operating pressure	
<b>A - B - B</b>	TMA Maximum allowable temperature	400 °C @ 59.5 bar g
	Minimum allowable temperature	-29 °C
<b>PN100</b>	TMO Maximum operating temperature	Standard packing PTFE chevron (P) 250 °C @ 76.1 bar g High temperature packing (H) 400 °C @ 59.5 bar g
	Minimum operating temperature	-29 °C
	Design for a maximum cold hydraulic test pressure of:	156 bar g
	Body design conditions	PN63
	PMA Maximum allowable pressure	63 bar g @ 50 °C
	PMO Maximum operating pressure	
<b>A - C - C</b>	TMA Maximum allowable temperature	400 °C @ 37.5 bar g
	Minimum allowable temperature	-29 °C
<b>PN63</b>	TMO Maximum operating temperature	Standard packing PTFE chevron (P) 250 °C @ 48.0 bar g High temperature packing (H) 400 °C @ 37.5 bar g
	Minimum operating temperature	-29 °C
	Design for a maximum cold hydraulic test pressure of:	94.5 bar g
	Body design conditions	PN40
	PMA Maximum allowable pressure	40 bar g @ 50 °C
	PMO Maximum operating pressure	
<b>A - D - D</b>	TMA Maximum allowable temperature	400 °C @ 23.8 bar g
	Minimum allowable temperature	-29 °C
<b>PN40</b>	TMO Maximum operating temperature	Standard packing PTFE chevron (P) 250 °C @ 30.4 bar g High temperature packing (H) 400 °C @ 23.8 bar g
	Minimum operating temperature	-10 °C
	Design for a maximum cold hydraulic test pressure of:	60 bar g

## BBV43 Pressure/temperature limits - ASME

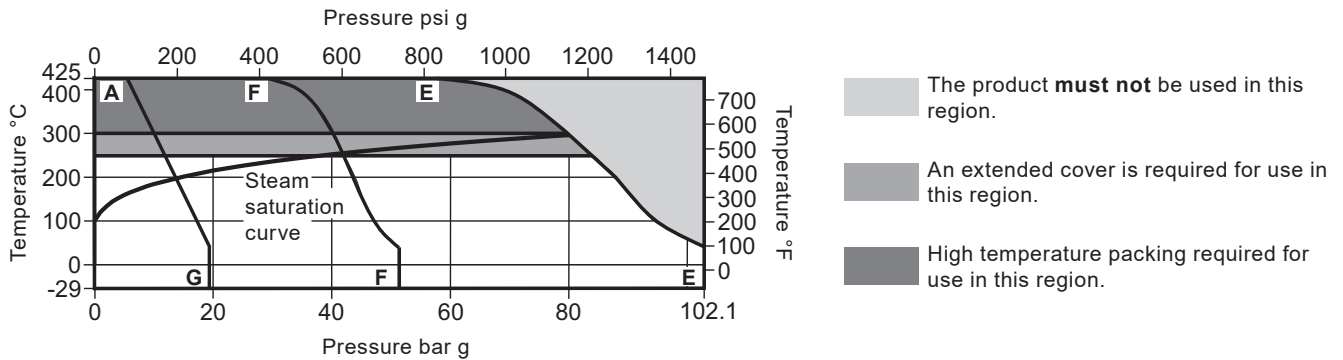

### Notes:

- Where the process fluid temperature is sub-zero and the ambient temperature is below +5 °C (+41 °F), the external moving parts of the valve and actuator must be heat traced to maintain normal operation.
- When selecting a valve with a bellows scaled bonnet, the pressure/temperature limits of the bellows must be read in conjunction with the valve pressure/temperature limits shown in table below.

	Body design conditions	ASME 600	
	PMA Maximum allowable pressure	102.1 bar g @ 38 °C	1480 psi g @ 100 °F
	PMO Maximum operating pressure		
<b>A - E - E</b>	TMA Maximum allowable temperature	425 °C @ 57.5 bar g	797 °F @ 834 psi g
	Minimum allowable temperature	-29 °C	-20 °F
<b>ASME 600</b>	TMO Maximum operating temperature	Standard packing PTFE chevron (P)	250 °C @ 83.6 bar g 482 °F @ 1212 psi g
		High temperature packing (H)	425 °C @ 57.5 bar g 797 °F @ 834 psi g
	Minimum operating temperature	-29 °C	-20 °F
	Design for a maximum cold hydraulic test pressure of:	156 bar g	2 262 psi g
	Body design conditions	ASME 300	
	PMA Maximum allowable pressure	51.1 bar g @ 38 °C	740 psi g @ 100 °F
	PMO Maximum operating pressure		
<b>A - F - F</b>	TMA Maximum allowable temperature	425 °C @ 28.8 bar g	797 °F @ 418 psi g
	Minimum allowable temperature	-29 °C	-20 °F
<b>ASME 300</b>	TMO Maximum operating temperature	Standard packing PTFE chevron (P)	250 °C @ 41.9 bar g 482 °F @ 608 psi g
		High temperature packing (H)	425 °C @ 28.8 bar g 797 °F @ 418 psi g
	Minimum operating temperature	-29 °C	-20 °F
	Design for a maximum cold hydraulic test pressure of:	77 bar g	1 117 psi g
	Body design conditions	ASME 150	
	PMA Maximum allowable pressure	19.6 bar g @ 38 °C	284 psi g @ 100 °F
	PMO Maximum operating pressure		
<b>A - G</b>	TMA Maximum allowable temperature	425 °C @ 5.5 bar g	797 °F @ 80 psi g
	Minimum allowable temperature	-29 °C	-20 °F
<b>ASME 150</b>	TMO Maximum operating temperature	Standard packing PTFE chevron (P)	250 °C @ 12.1 bar g 482 °F @ 175 psi g
		High temperature packing (H)	425 °C @ 5.5 bar g 797 °F @ 80 psi g
	Minimum operating temperature	-29 °C	-20 °F
	Design for a maximum cold hydraulic test pressure of:	77 bar g	1 117 psi g

## BBV43 Pressure/temperature limits - JIS/KS

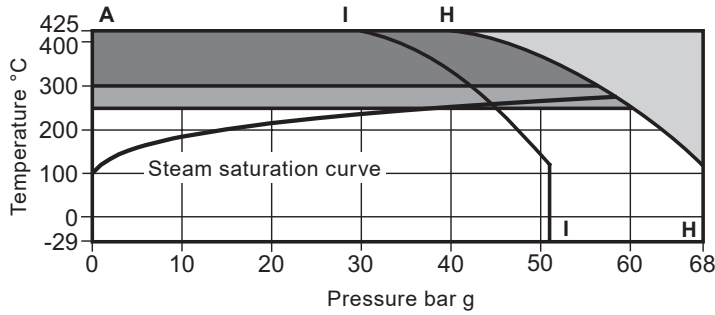

### Notes:

1. Where the process fluid temperature is sub-zero and the ambient temperature is below +5 °C, the external moving parts of the valve and actuator must be heat traced to maintain normal operation.
2. When selecting a valve with a bellows scaled bonnet, the pressure/temperature limits of the bellows must be read in conjunction with the valve pressure/temperature limits shown in table below.

	Body design conditions	JIS/KS40
	PMA Maximum allowable pressure	68 bar g @ 120 °C
	PMO Maximum operating pressure	
<b>A - H - H</b>	TMA Maximum allowable temperature	425 °C @ 40 bar g
<b>JIS/KS 40</b>	Minimum allowable temperature	-29 °C
	TMO Maximum operating temperature	Standard packing PTFE chevron (P) 250 °C @ 60 bar g High temperature packing (H) 425 °C @ 40 bar g
	Minimum operating temperature	-29 °C
	Design for a maximum cold hydraulic test pressure of:	156 bar g
	Body design conditions	JIS/KS30
	PMA Maximum allowable pressure	51 bar g @ 120 °C
	PMO Maximum operating pressure	
<b>A - I - I</b>	TMA Maximum allowable temperature	425 °C @ 30 bar g
<b>JIS/KS 30</b>	Minimum allowable temperature	-29 °C
	TMO Maximum operating temperature	Standard packing PTFE chevron (P) 250 °C @ 45 bar g High temperature packing (H) 425 °C @ 30 bar g
	Minimum operating temperature	-29 °C
	Design for a maximum cold hydraulic test pressure of:	156 bar g

## BBV63 Pressure/temperature limits - EN 1092

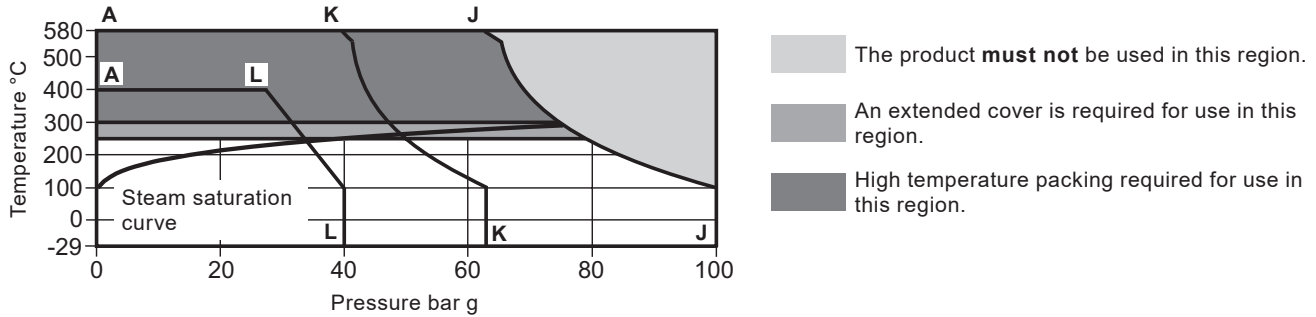

### Notes:

1. Where the process fluid temperature is sub-zero and the ambient temperature is below +5 °C, the external moving parts of the valve and actuator must be heat traced to maintain normal operation.
2. When selecting a valve with a bellows scaled bonnet, the pressure/temperature limits of the bellows must be read in conjunction with the valve pressure/temperature limits shown in table below.

	Body design conditions	PN100
	PMA Maximum allowable pressure	100 bar g @ 100 °C
	PMO Maximum operating pressure	
<b>A - J - J</b>	TMA Maximum allowable temperature	580 °C @ 62.7 bar g
	Minimum allowable temperature	-29 °C
<b>PN100</b>	TMO Maximum operating temperature	Standard packing PTFE chevron (P) 250 °C @ 79.6 bar g High temperature packing (H) 580 °C @ 62.7 bar g
	Minimum operating temperature	-29 °C
	Design for a maximum cold hydraulic test pressure of:	156 bar g
	Body design conditions	PN63
	PMA Maximum allowable pressure	63 bar g @ 100 °C
	PMO Maximum operating pressure	
<b>A - K - K</b>	TMA Maximum allowable temperature	580 °C @ 39.5 bar g
	Minimum allowable temperature	-29 °C
<b>PN63</b>	TMO Maximum operating temperature	Standard packing PTFE chevron (P) 250 °C @ 50.1 bar g High temperature packing (H) 580 °C @ 39.5 bar g
	Minimum operating temperature	-29 °C
	Design for a maximum cold hydraulic test pressure of:	156 bar g
	Body design conditions	PN40
	PMA Maximum allowable pressure	40 bar g @ 100 °C
	PMO Maximum operating pressure	
<b>A - L - L</b>	TMA Maximum allowable temperature	400 °C @ 27.4 bar g
	Minimum allowable temperature	-29 °C
<b>PN40</b>	TMO Maximum operating temperature	Standard packing PTFE chevron (P) 250 °C @ 31.8 bar g High temperature packing (H) 400 °C @ 27.4 bar g
	Minimum operating temperature	-29 °C
	Design for a maximum cold hydraulic test pressure of:	60 bar g



# BBV63 Pressure/temperature limits - ASME

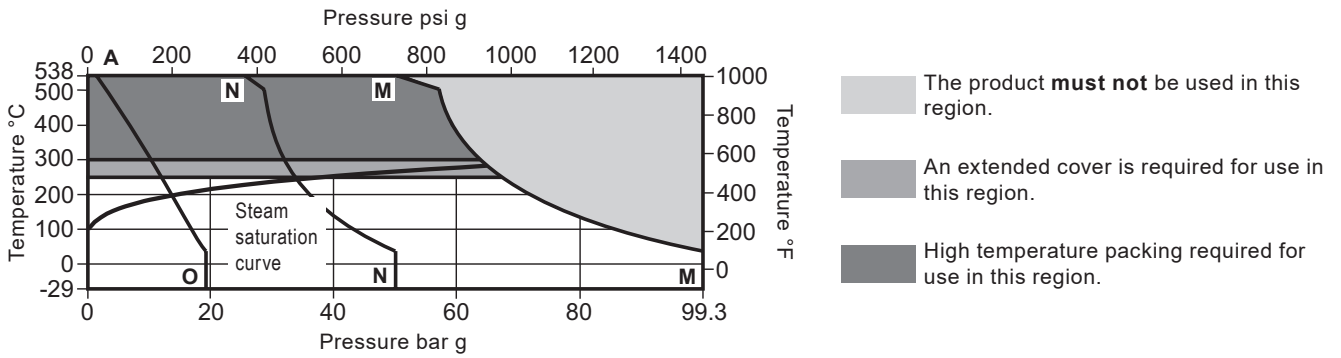

**Notes:**

1. Where the process fluid temperature is sub-zero and the ambient temperature is below +5 °C, the external moving parts of the valve and actuator must be heat traced to maintain normal operation.
2. When selecting a valve with a bellows scaled bonnet, the pressure/temperature limits of the bellows must be read in conjunction with the valve pressure/temperature limits shown in table below.

Body design conditions		ASME 600	
PMA Maximum allowable pressure		99.3 bar g @ 38 °C	1440 psi g @ 100 °F
PMO Maximum operating pressure			
TMA Maximum allowable temperature		538 °C @ 50 bar g	1000 °F @ 725 psi g
Minimum allowable temperature		-29 °C	-20 °F
<b>A - M - M</b>			
<b>ASME 600</b>	TMO Maximum operating temperature	Standard packing PTFE chevron (P)	250 °C @ 66.8 bar g    482 °F @ 967 psi g
		High temperature packing (H)	538 °C @ 50 bar g    1000 °F @ 725 psi g
Minimum operating temperature		-29 °C	-20 °F
Design for a maximum cold hydraulic test pressure of:		156 bar g	2 262 psi g
Body design conditions		ASME 300	
PMA Maximum allowable pressure		49.6 bar g @ 38 °C	1440 psi g @ 100 °F
PMO Maximum operating pressure			
TMA Maximum allowable temperature		538 °C @ 25.2 bar g	1000 °F @ 365 psi g
Minimum allowable temperature		-29 °C	-20 °F
<b>A - N - N</b>			
<b>ASME 300</b>	TMO Maximum operating temperature	Standard packing PTFE chevron (P)	250 °C @ 33.4 bar g    482 °F @ 484 psi g
		High temperature packing (H)	538 °C @ 25.2 bar g    1000 °F @ 365 psi g
Minimum operating temperature		-29 °C	-20 °F
Design for a maximum cold hydraulic test pressure of:		75 bar g	1 087 psi g
Body design conditions		ASME 150	
PMA Maximum allowable pressure		19 bar g @ 38 °C	275 psi g @ 100 °F
PMO Maximum operating pressure			
TMA Maximum allowable temperature		538 °C @ 1.4 bar g	1000 °F @ 20 psi g
Minimum allowable temperature		-29 °C	-20 °F
<b>A - O</b>			
<b>ASME 150</b>	TMO Maximum operating temperature	Standard packing PTFE chevron (P)	250 °C @ 12.1 bar g    482 °F @ 175 psi g
		High temperature packing (H)	538 °C @ 1.4 bar g    1000 °F @ 20 psi g
Minimum operating temperature		-29 °C	-20 °F
Design for a maximum cold hydraulic test pressure of:		29 bar g	2 262 psi g

## BBV63 Pressure/temperature limits - JIS/KS

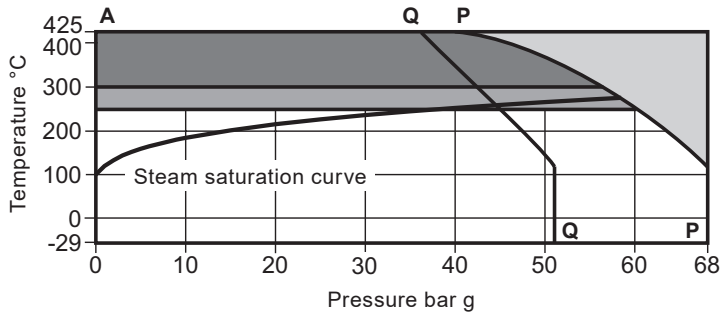

### Notes:

1. Where the process fluid temperature is sub-zero and the ambient temperature is below +5 °C, the external moving parts of the valve and actuator must be heat traced to maintain normal operation.
2. When selecting a valve with a bellows scaled bonnet, the pressure/temperature limits of the bellows must be read in conjunction with the valve pressure/temperature limits shown in table below.

	Body design conditions	JIS/KS 40
	PMA Maximum allowable pressure	68 bar g @ 120 °C
	PMO Maximum operating pressure	
<b>A - P - P</b>	TMA Maximum allowable temperature	425 °C @ 40 bar g
	Minimum allowable temperature	-29 °C
<b>JIS/KS 40</b>	TMO Maximum operating temperature	Standard packing PTFE chevron (P) 250 °C @ 60 bar g High temperature packing (H) 425 °C @ 40 bar g
	Minimum operating temperature	-29 °C
	Design for a maximum cold hydraulic test pressure of:	156 bar g
	Body design conditions	JIS/KS 30
	PMA Maximum allowable pressure	51 bar g @ 120 °C
	PMO Maximum operating pressure	
<b>A - Q - Q</b>	TMA Maximum allowable temperature	425 °C @ 36 bar g
	Minimum allowable temperature	-29 °C
<b>JIS/KS 30</b>	TMO Maximum operating temperature	Standard packing PTFE chevron (P) 250 °C @ 45 bar g High temperature packing (H) 425 °C @ 36 bar g
	Minimum operating temperature	-29 °C
	Design for a maximum cold hydraulic test pressure of:	156 bar g

## BBV83 Pressure/temperature limits - EN 1092

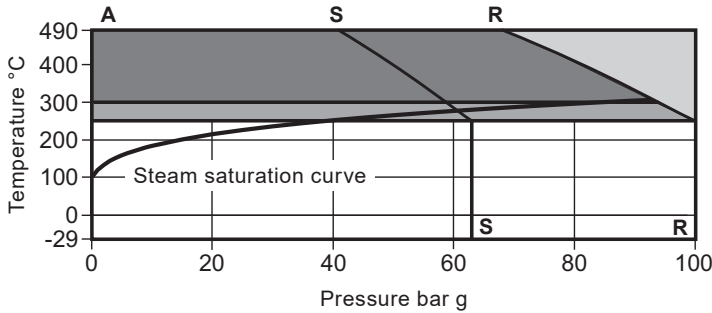

- The product **must not** be used in this region.
- An extended cover is required for use in this region.
- High temperature packing required for use in this region.

### Notes:

1. Where the process fluid temperature is sub-zero and the ambient temperature is below +5 °C, the external moving parts of the valve and actuator must be heat traced to maintain normal operation.
2. When selecting a valve with a bellows scaled bonnet, the pressure/temperature limits of the bellows must be read in conjunction with the valve pressure/temperature limits shown in table below.

	Body design conditions	PN100
	PMA Maximum allowable pressure	100 bar g @ 250 °C
	PMO Maximum operating pressure	
<b>A - R - R</b>	TMA Maximum allowable temperature	490 °C @ 68 bar g
<b>PN100</b>	Minimum allowable temperature	-29 °C
	TMO Maximum operating temperature	Standard packing PTFE chevron (P) 250 °C @ 100 bar g High temperature packing (H) 490 °C @ 68 bar g
	Minimum operating temperature	-29 °C
	Design for a maximum cold hydraulic test pressure of:	156 bar g
	Body design conditions	PN63
	PMA Maximum allowable pressure	63 bar g @ 250 °C
	PMO Maximum operating pressure	
<b>A - S - S</b>	TMA Maximum allowable temperature	490 °C @ 40.9 bar g
<b>PN63</b>	Minimum allowable temperature	-29 °C
	TMO Maximum operating temperature	Standard packing PTFE chevron (P) 250 °C @ 63 bar g High temperature packing (H) 490 °C @ 40,9 bar g
	Minimum operating temperature	-29 °C
	Design for a maximum cold hydraulic test pressure of:	156 bar g

## BBV83 Pressure/temperature limits - ASME

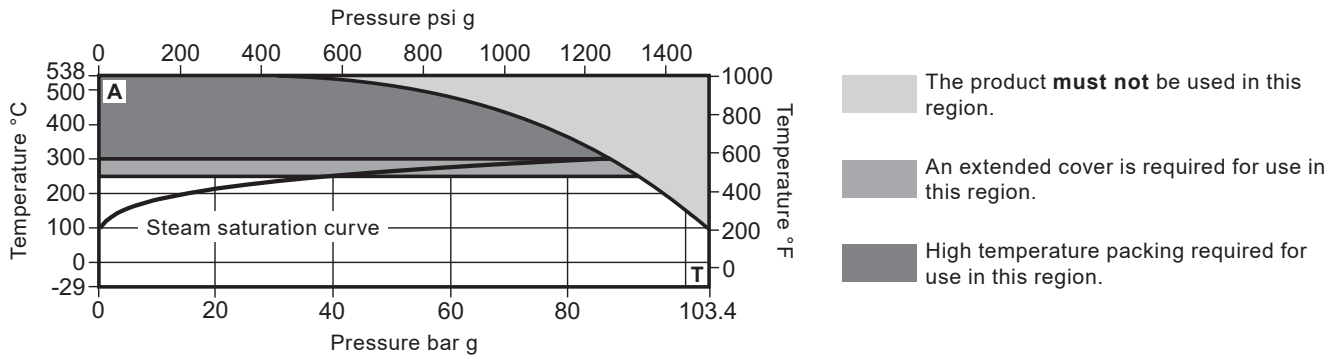

### Notes:

- Where the process fluid temperature is sub-zero and the ambient temperature is below +5 °C (+41 °F), the external moving parts of the valve and actuator must be heat traced to maintain normal operation.
- When selecting a valve with a bellows scaled bonnet, the pressure/temperature limits of the bellows must be read in conjunction with the valve pressure/temperature limits shown in table below.

Body design conditions		ASME 600	
PMA Maximum allowable pressure			
PMO Maximum operating pressure		103.4 bar g @ 38 °C	1499 psi g @ 100 °F
<b>A - T</b>	TMA Maximum allowable temperature	538 °C @ 29.8 bar g	1000 °F @ 432 psi g
	Minimum allowable temperature	-29 °C	-20 °F
<b>ASME 600</b>	TMO Maximum operating temperature		
		Standard packing PTFE chevron (P)	250 °C @ 92.7 bar g    482 °F @ 1344 psi g
		High temperature packing (H)	538 °C @ 29.8 bar g    1000 °F @ 432 psi g
	Minimum operating temperature	-29 °C	-20 °F
Design for a maximum cold hydraulic test pressure of:		156 bar g	2262 psi g

## BBV83 Pressure/temperature limits - JIS/KS

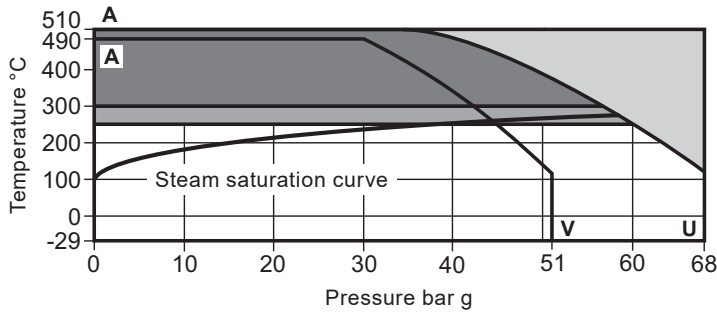

- The product **must not** be used in this region.
- An extended cover is required for use in this region.
- High temperature packing required for use in this region.

### Notes:

1. Where the process fluid temperature is sub-zero and the ambient temperature is below +5 °C, the external moving parts of the valve and actuator must be heat traced to maintain normal operation.
2. When selecting a valve with a bellows scaled bonnet, the pressure/temperature limits of the bellows must be read in conjunction with the valve pressure/temperature limits shown in table below.

	Body design conditions	JIS/KS 40
	PMA Maximum allowable pressure	68 bar g @ 120 °C
	PMO Maximum operating pressure	
<b>A - U</b>	TMA Maximum allowable temperature	510 °C @ 36 bar g
	Minimum allowable temperature	-29 °C
<b>JIS/KS 40</b>	TMO Maximum operating temperature	Standard packing PTFE chevron (P) 250 °C @ 60 bar g High temperature packing (H) 510 °C @ 36 bar g
	Minimum operating temperature	-29 °C
	Design for a maximum cold hydraulic test pressure of:	156 bar g
	Body design conditions	JIS/KS 30
	PMA Maximum allowable pressure	51 bar g @ 120 °C
	PMO Maximum operating pressure	
<b>A - V</b>	TMA Maximum allowable temperature	490 °C @ 30 bar g
	Minimum allowable temperature	-29 °C
<b>JIS/KS 30</b>	TMO Maximum operating temperature	Standard packing PTFE chevron (P) 250 °C @ 45 bar g High temperature packing (H) 490 °C @ 30 bar g
	Minimum operating temperature	-29 °C
	Design for a maximum cold hydraulic test pressure of:	156 bar g

**Dimensions/Weights** (approximate) in mm and kg

**Flanged EN 1092**

Size	A		B		C		C1		D	E	F	Weight
	PN40	PN63/PN100	PN40	PN63/PN100	PN40	PN63/PN100	PN40	PN63/PN100				
DN15	130	210	103	105	330	335	242	247	170	246	388	10.0
DN20	150	230	103	108	330	335	242	247				10.8
DN25	160	230	103	108	330	335	242	247				11.0
DN32	180	260	132	132	359	359	271	271				17.5
DN40	200	260	132	132	359	359	271	271				18.0
DN50	230	300	127	127	354	354	266	266				21.0

**Flanged ASME**

Size	A		B		C		C1		D	E	F	Weight
	ASME 300	ASME 600	ASME 300	ASME 600	ASME 300	ASME 600	ASME 300	ASME 600				
DN15	190.5	203	103	105	330	335	242	247	170	200	272	10.0
DN20	190.5	206	103	108	330	335	242	247	170	200	272	10.8
DN25	196.9	210	103	108	330	335	242	247	170	200	272	11.0
DN32		251		132		359		271		200		17.5
DN40	235.0	251	132	132	359	359	271	271	170	200	272	18.0
DN50	266.7	286	127	127	354	354	266	266	170	200	272	21.0

**Butt weld and Socket weld**

Size	A	B	C	C1	D	E	F	Weight
DN15	203	105	335	247	170	246	388	10.0
DN20	206	108	335	247				10.8
DN25	210	108	359	247				11.0
DN32	251	132	359	271				17.5
DN40	251	132	359	271				18.0
DN50	286	127	354	266				21.0

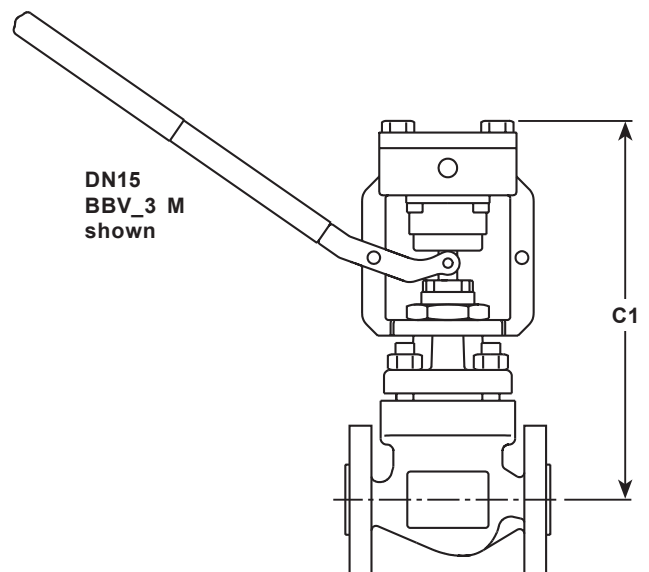
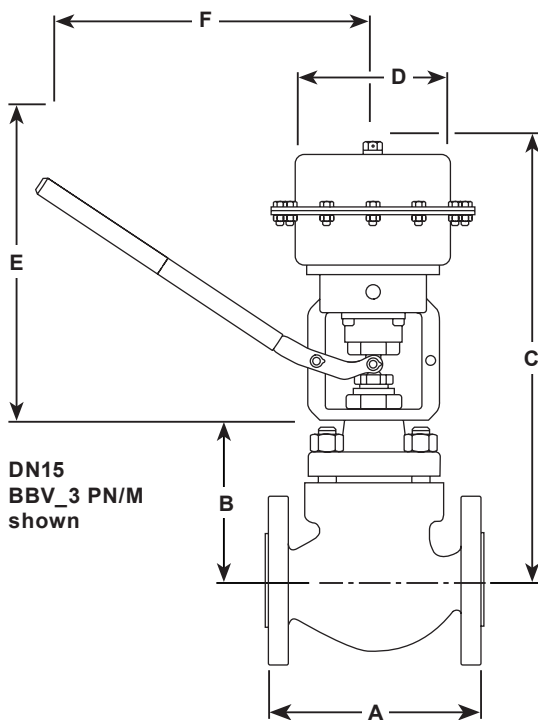

## Spare parts

### PN40

### ASME 150 and ASME 300

The spare parts available are shown in solid outline. Parts drawn in a grey line are not supplied as spares.

**Note:** When placing an order for spare parts please specify clearly the full product description as found on the label of the valve body, as this will ensure that the correct spare parts are supplied.

#### Available spares - BBV series

Actuator clamping nut		<b>A</b>
Gasket set	(Non-bellows sealed)	<b>B, G</b>
Stem seal kits	PTFE to Graphite conversion kit	<b>C1</b>
	Graphite packing	<b>C2</b>
Plug stem and seat kit	Fast opening trim (No gaskets supplied)	<b>D1, E</b>

#### How to order spares

Always order spares by using the description given in the column headed 'Available spares', and state the size and type of valve including the full product description of the product.

**Example:** 1 - PTFE stem seal kit for a Spirax Sarco BBV43 PWSUSS DN25 PN40 control valve.

#### How to fit spares

Full fitting instructions are given in the Installation and Maintenance Instructions supplied with the spare.

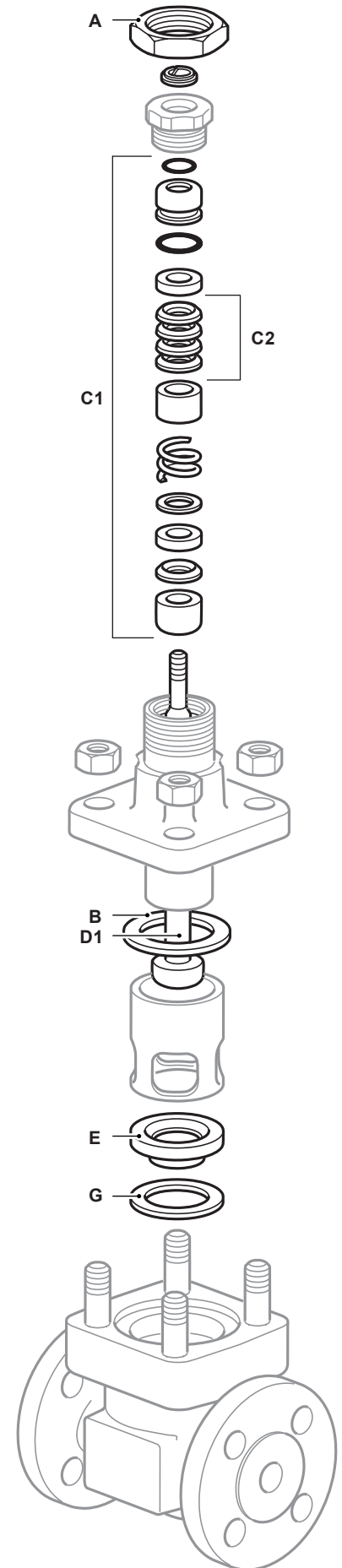

## Spare parts

### PN63 and PN100 ASME 600 JIS/KS 30 and JIS/KS 40

The spare parts available are shown in solid outline. Parts drawn in broken line are not supplied as spares.

**Note:** When placing an order for spare parts please specify clearly the full product description as found on the label of the valve body, as this will ensure that the correct spare parts are supplied.

#### Available spares – BBV

Actuator clamping nut		<b>A</b>
Gasket set		<b>B, G</b>
Stem seal kits	Graphite packing	<b>C1</b>
Plug stem and seat kit	Fast opening trim (No gaskets supplied)	<b>D1, E</b>

#### How to order spares

Always order spares by using the description given in the column headed 'Available spares', and state the size and type of valve including the full product description of the product.

**Example:** 1 - Plug stem and seat kit for a Spirax Sarco BBV43 PWSUSS DN25 PN63 two-port control valve having flanged PN63 connections.

#### How to fit spares

Full fitting instructions are given in the Installation and Maintenance Instructions supplied with the spare.

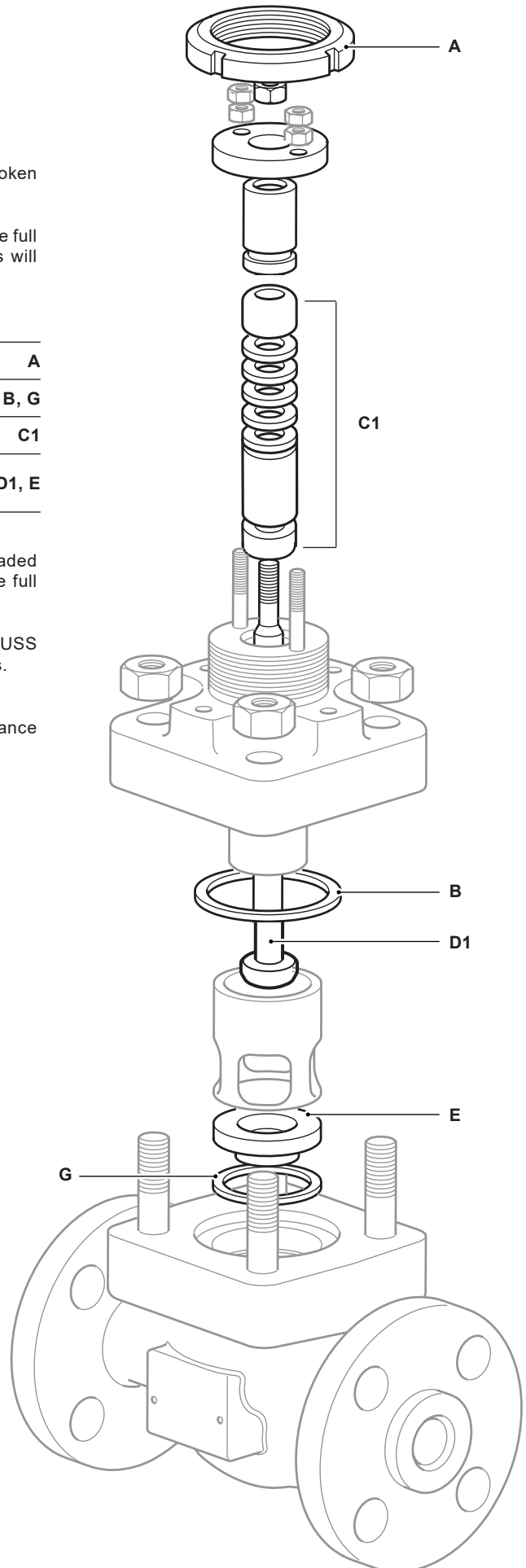



## BBV selection guide:

<b>Valve series</b>	BBV = Boiler blowdown valve	<b>BBV</b>
<b>Body material</b>	4 = Carbon steel	<b>4</b>
	6 = Stainless steel	
	8 = Alloy steel	
<b>Connections</b>	1 = Screwed	<b>3</b>
	3 = Flanged	
<b>Stem sealing</b>	P = PTFE	<b>P</b>
	H = Graphite	
<b>Seating</b>	W = Stellite	<b>W</b>
<b>Type of trim</b>	S = Standard trim	<b>S</b>
<b>Trim balancing</b>	U = Unbalanced	<b>U</b>
<b>Bonnet type</b>	S = Standard	<b>S</b>
<b>Bolting</b>	S = Standard	<b>S</b>
<b>Valve size</b>	= DN15, DN20, DN25, DN32, DN40 and DN50 = ½", ¾", 1", 1¼", 1½" and 2"	<b>DN20</b>
<b>Connections For alternative connections</b> to those stated please contact Spirax Sarco.	EN standard = Flanged EN 1092 PN40, PN63 and PN100	<b>PN40</b>
	ASME standard = Flanged ASME 300 and ASME 600	
	Butt weld	
	Socket weld	
<b>Version</b>	PN/M = Air pneumatically actuated supplied with a manual actuation lever	<b>PN/M</b>
	M = Manually actuated complete with a manual actuation lever	

<b>Selection example:</b>	BBV	4	3	P	W	S	U	S	S	DN20	PN40	PN/M
---------------------------	-----	---	---	---	---	---	---	---	---	------	------	------

**How to order example:** 1 off Spirax Sarco BBV43PWSUSS DN20 PN/M