



## B850 Boiler House Energy Monitor

### Description

The B850 is a flexible and easy to use Boiler House Energy Monitor that accurately calculates the efficiency of the boiler based on measured inputs from fuel, feedwater, steam output, condensate return and blowdown.

**The B850 is a boiler house energy monitoring solution** that has been designed for organisations operating boilers on an existing installed base and for boiler OEM's where customers specify a requirement for energy monitoring. The B850 calculates a boiler's 'real time' energy transfer efficiency from fuel to steam. It will also measure for energy losses from the boiler due to blowdown applications.

Being fully compatible with a wide range of Spirax Sarco flowmetering products the B850 is the heart of a fully integrated system that will provide Operating Managers in an increasing range of industries detailed information to be able to review boiler efficiency against past performance.

The unit is available for either wall or panel mounting. The **B850-W-2** and **B850-W-2-UL** are wall mounted versions are mains powered (100 to 250 Vac), while the **B850-P-2** panel mounting version is intended for direct connection to a Low Voltage power supply typically found inside PLC panels, i.e. 24 Vdc.

The B850 is supplied with a default configuration that makes configuration easy, either off-line with the free PC based software wizard provided with each product. When the configuration has been completed, it can be saved to file or to the free USB memory stick provided, from where it can be plugged in and up-loaded directly into the unit. Alternatively, commissioning can be carried out via a hierarchical menu structure through the front panel. Full commissioning details are included in the Installation and Maintenance Instructions (IMI) supplied with the unit.

Spirax Sarco offers a complete range of flowmeters for the measurement of: Gas, Feedwater, Steam and make-up water.

For existing installed flowmeters the B850 can accept 4-20 mA, Pulse and RTD inputs.

**The B850 is compatible with a large number of interfaces and protocols including:** RS-485, Modbus RTU, BACnet MSTP, RJ-45 Ethernet, Modbus TCP/IP, BACnet IP, USB and Hosted http web.

A GSM module can be connected to the RS-485 port which enables transfer of information about failures, alarms and measurement values in the form of SMS text messages.

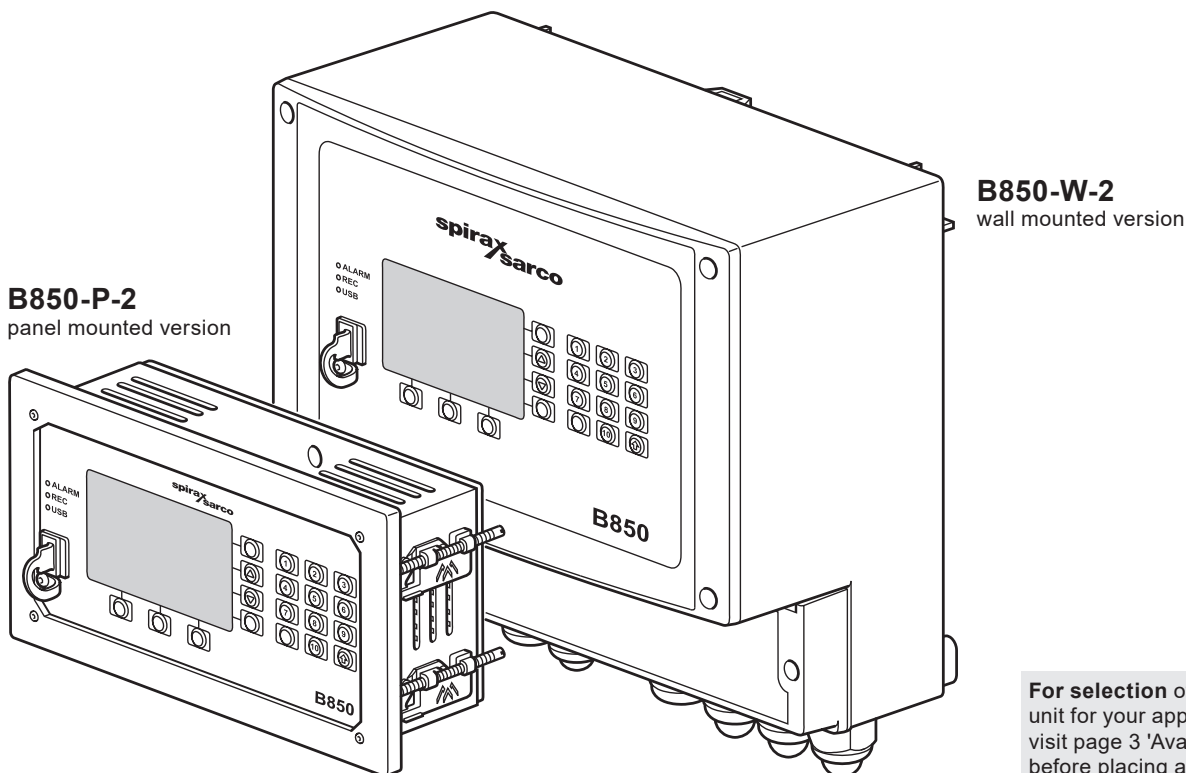

## Standards and certification

This range of products fully comply with the requirements of the European Directives and carry the  mark when so required. In addition there is an cULus certified version of the wall mount variant available

### The B850 is available with the following certification:

- Uncertainty Certificate / Inspection Report.

**Note:** All certification/inspection requirements must be stated at the time of order placement.

### The B850 can calculate and display:

- Energy transfer efficiency from fuel to steam
- Potential energy losses from TDS and bottom blowdown applications
- Energy recovery from condensate return
- Steam flow and pressure
- Feedwater flow and temperature
- Fuel flow

## Applications

Application	Proposed flowmeter (B850 is the example supplied )	Meter output
Gas (Oil, Coal)	Thermal mass flowmeter for gas (MTL10)	(0) 4 - 20 mA
Boiler feedwater	Magnetic flowmeter (ELM)	(0) 4 - 20 mA
Boiler steam output	Flowmeter (Gilflo, ILVA)	(0) 4 - 20 mA
Make-up water	Magnetic flowmeter (ELM)	(0) 4 - 20 mA
TDS blowdown	TDS valve	Relay (State)
BB blowdown	BBD valve	Relay (State)

## Typical boiler house application

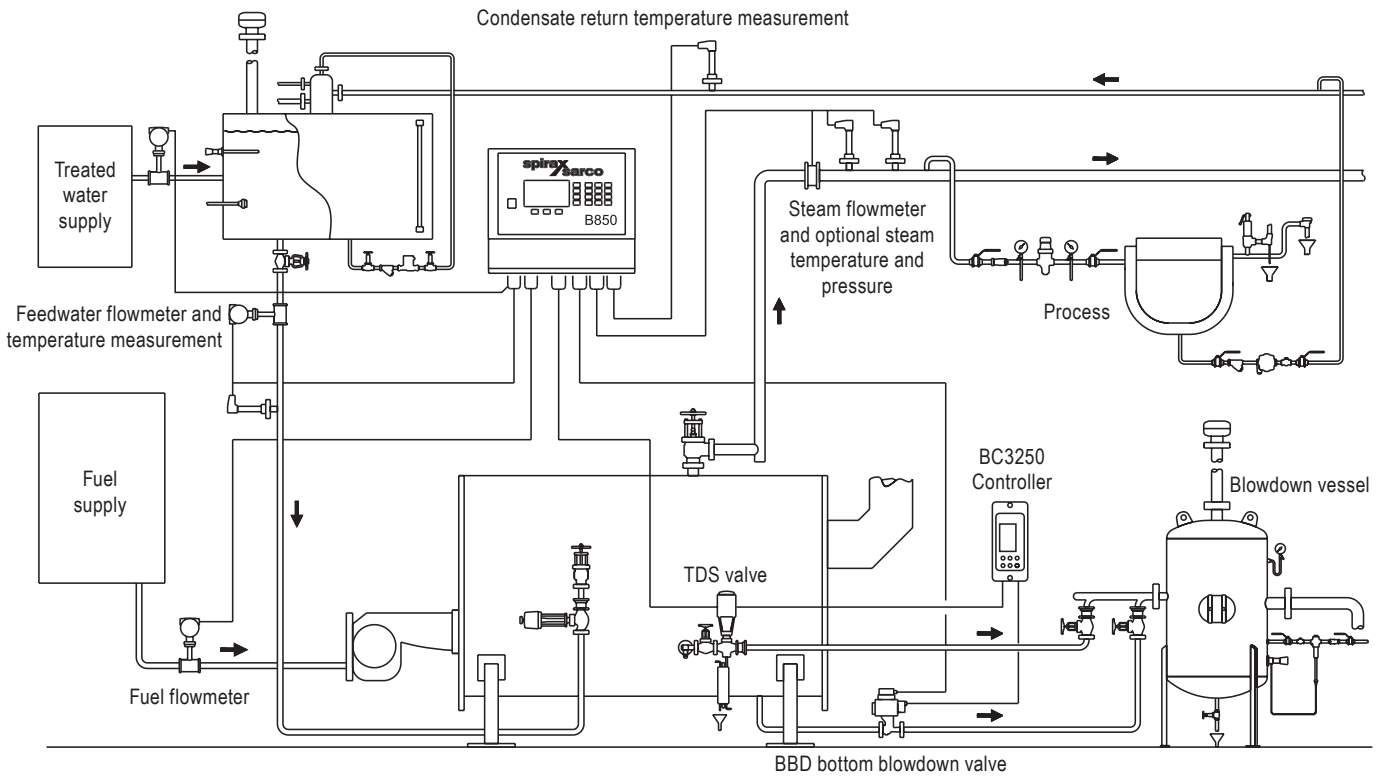

### Available options

The following versions of the B850 series have the same functions and are available as follows:

**B850-P** for panel mounting and is powered by 24 Vdc.

**Each version** is equipped with two analog outputs

**B850-W** for wall mounting and has been adapted to be powered by 100 / 240 Vac.

### Offered versions of the instruments:

B850 -x -2 -x	
-P	<b>Panel mounted version.</b> (CE and cULus approved as standard)
-W	<b>Wall mounted version.</b> (CE approved as standard, cULus approval optional)
-2	Two analog 4-20 mA outputs.
-UL	Option with cULus approval (required for wall mount version only)





**B850-W-2**  
wall mounted version

**B850-P-2**  
panel mounted version

## Technical data for the B850 series flow computers

User interface, front panel		
Display type	LCD TFT color, 3.5", with LED backlight	
Display size / resolution	43.8 mm x 77.4 mm / 272 (RGB) x 480 px,	
LED indication	3 two-color LEDs, red / green: ALARM, REC, USB	
Keyboard	19 membrane buttons	
Inputs organization		
Number of inputs	6 x I type (0/4-20 mA):	IN1, IN2, IN3, IN4, IN5, IN6
	3 x RTD (4-wire):	IN7, IN8, IN9
	3 x PULS:	IN10, IN11, IN12
I type (0/4-20 mA current loop analog inputs)		
Signal type	0-20 mA or 4-20 mA	
Transmitter connection	2-wire passive transmitter (supplied from B850) or active transmitter (current source transmitter)	
Input resistance	95 $\Omega$ $\pm$ 10% (protected with PTC 50 mA fuse in series)	
Transmitters supply	24 Vdc +10% / -20%; max 22 mA per channel (protected with PTC 50 mA fuse and 100 $\Omega$ resistor in series)	
A/C converter resolution	18 bit (24 bit Sigma-Delta ADC)	
50 Hz / 60 Hz filter	Sinc3 digital filter	
Damping (1 <sup>st</sup> order Low Pass Software Filter time constant)	2 s / 5 s / 10 s / 20 s / 30 s / 1 min / 2 min / 3 min / 5 min	
Measurement resolution	> 0.01% of FS	
Accuracy (at T <sub>amb</sub> = +25 °C / +77 °F)	$\pm$ 0.1% of FS (typical $\Omega$ 0.05% of FS)	
Temperature drift	Maximum $\pm$ 0.02% of FS / °C	
Maximum input voltage	$\pm$ 40 Vdc / SELV	
Galvanic isolation between inputs	No; common potential of functional GND for all inputs	
Galvanic isolation to Analog Outputs, RS-485 / RS-422, Ethernet	250 Vac continuous; 1500 Vac for 1 minute	
RTD type (3 analog inputs for temperature sensors)		
Sensor types	Pt-100 x K; Ni-100 x K; where K = 1..11 (K – multiplier, e.g.: K = 2 for Pt-200)	
Measuring range	-200 .. +850 °C / -328 .. +1562 °F for Pt100 x K -60 .. +150 °C / -76 .. +302 °F for Ni100 x K	
Sensor connection	4-wire (2-wire with wire bridges)	
Wire resistance compensation	Automatic , additional manual in range -99.99 .. +99.99 $\Omega$	
Maximum resistance of connecting wires	50 $\Omega$	
A/C converter resolution	18 bit (24 bit Sigma-Delta ADC)	
50 Hz / 60 Hz filter	Sinc3 digital filter	
Damping (1 <sup>st</sup> order Low Pass Filter time constant)	2 s / 5 s / 10 s / 20 s / 30 s / 1 min / 2 min / 3 min / 5min	
Measurement resolution	> 0.05% of reading or 0.1 $\Omega$ (TBV)	
Accuracy (at T <sub>amb</sub> = +25 °C / +77 °F)	$\pm$ 0.5 °C / $\pm$ 0.9 °F (typical $\pm$ 0.3 °C / $\pm$ 0.54 °F)	
Temperature drift	Maximum $\pm$ 0.02 °C / °C / 0.036 °F / °F	
Max input voltage	$\pm$ 40 Vdc / SELV	
Galvanic isolation between inputs	No; common potential of functional GND for all inputs	
Galvanic isolation to Analog Outputs, RS-485 / RS-422, Ethernet	250 Vac continuous; 1500 Vac for 1 minute	

<b>PULS type inputs (binary / pulse / frequency)</b>	
Measuring range	0 .. 20 kHz (cut off for $f < 0.001$ Hz) (0 ..1 kHz with filter jumper J1 / J2 / J3 ON)
Minimum pulse width	25 $\mu$ s (0.5 ms with filter jumper J1 / J2 / J3 ON)
Accuracy for frequency measurement (at $T_{amb} = +25$ °C / +77 °F)	0.02%
Maximum input voltage	$\pm 40$ Vdc / SELV
Galvanic isolation between inputs	No; common potential of functional GND for all inputs
Galvanic isolation to Analog Outputs, RS-485/RS-422, Ethernet	250 Vac continuous; 1500 Vac for 1 minute
Configuration (default): OC or Contact open/closed	(Internal jumper J4 / J5 / J6 ON)
Open circuit voltage	5 Vdc
Short circuit current	5 mA
On / off threshold	2.7 V / 2.4 V
Configuration: Voltage Input	(Internal jumper J4 / J5 / J6 OFF)
Signal amplitude	4 .. 36 Vdc
On / off threshold	2.7 V / 2.4 V
Input resistance	$\geq 10$ k $\Omega$
<b>Compensated flow and heat energy measurement</b>	
Calculation update rate	1 s
Total accuracy of compensated steam, water, other liquid or technical gas flow measurement	Typical: better then $\pm 0.5\%$ (worst case: better then $\pm 2\%$ )
<b>4-20 mA analog outputs</b>	
Number of outputs	2
Output signal	4-20 mA passive (external current loop supply required)
Resolution	16 bit DAC
Loop resistance ( $R_L$ ) range for $U_{cc} = 24$ V	0 .. 600 $\Omega$
Minimum loop power supply voltage	$U_{ccmin} = R_L \times 0.022 + 8$
Maximum loop power supply voltage	28 Vdc / SELV
Accuracy (at $T_{amb} = +25$ °C / +77 °F)	Better than $\pm 0.2\%$ of FS / °C
Temperature drift	Maximum $\pm 0.02\%$ of FS / °C
Galvanic isolation to Analog Inputs, RS-485 / RS-422, Ethernet	250 Vac continuous; 1500 Vac for 1 minute
<b>Binary outputs (B850-W-2 and B850-W-2-UL)</b>	
Number of outputs	4
Type of outputs	3 pole (COM, NO, NC) electromechanical relay
Contact rating (resistive load)	3 A at 85 .. 250 Vac / 30 Vdc
Maximum switching voltage	250 Vac / 125 Vdc
Maximum switching power	750 VA / 90 W
<b>Binary outputs (B850-P-2)</b>	
Number of outputs	4
Type of outputs	2 pole Solid State Relay
Contact rating (resistive load)	0.1 A at 24 Vac/dc (max 42 Vac 60 Vdc) / SELV
Maximum ON resistance	20 $\Omega$
Galvanic isolation (optoisolation)	250 Vac continuous; 1500 Vac for 1 minute

<b>RS-485/422</b>	
Transmission protocol	ASCII Modbus RTU, BACnet MSTP and GSM
Number of nodes in network	256
Maximum line length	1 200 m (depends on quality of data cable and baud rate)
Baud rate	2.4, 4.8, 9.6, 19.2, 38.4, 57.6, 115.2, 230.4 kbps
Parity control	Even, Odd, None
Frame	1 start bit, 8 data bits, parity 1 bit, 1 stop bit
Internal terminating resistor	Yes, activated with DIP switch
Maximum bus terminal voltages	-8 V ... +13 V / SELV
Minimal driver differential output voltage	1.5 V (for $R_L = 54 \Omega$ )
Minimum receiver sensitivity	200 mV
Short-circuit / thermal protection	Yes
Galvanic isolation to Analog Inputs, Analog Outputs, Ethernet	250 Vac continuous; 1500 Vac for 1 minute
<b>Ethernet port</b>	
Transmission protocol	Modbus TCP, ICMP (ping), DHCP server, http server, BACnet IP
Interface	10 BaseT Ethernet
Data buffer	300 B
Number of opened connections (simultaneously)	4
Connection type	RJ-45 / SELV
LED indication	2 (build in RJ-45 socket)
<b>USB port</b>	
Socket type	A type, according to USB standard
Version	USB 2.0
Recording format	FAT16 (within a limited scope)
<b>Power supply (B850-W-2 and B850-W-2-UL)</b>	
Rated supply voltage	100-240 Vac; 50/60 Hz 
Supply voltage range	85 .. 264 Vac; 47 .. 63 Hz 
Power consumption	Maximum 20 VA
Over voltage category	CAT III
<b>Power supply (B850-P-2)</b>	
Rated supply voltage	24 Vdc  (SELV and Limited Energy Supply)
Supply voltage range	18 .. 36 Vdc 
Power consumption	Maximum 8 W
<b>Wire terminals (B850-W-2 and B850-W-2-UL)</b>	
Wire connection / terminals	Spring type terminal block
Conductor cross Section	Solid 0.2 .. 2.5 mm <sup>2</sup> Stranded 0.2 .. 1.5 mm <sup>2</sup> Stranded with ferrule 0.25 .. 1.5 mm <sup>2</sup> AWG 26 .. 12
Non cULus Version cable entry	4 glands type M20, 2 glands type M16
cULus Version cable entry	4 conduit hubs ½" NPT

<b>Wire terminals (B850-P-2)</b>	
Wire connection / terminals	Screw type terminal blocks, plug type
Conductor cross Section	Solid 1.5 mm <sup>2</sup> max Stranded 1 mm <sup>2</sup> max Stranded with ferrule 0.25 .. 1.5 mm <sup>2</sup> AWG 30/14
<b>Enclosure (B850-W-2 and B850-W-2-UL)</b>	
Enclosure type	Wall mounting, Polycarbonate material
Dimensions (height x width x depth)	217 mm x 257 mm x 134 mm (without cable glands) 238 mm x 257 mm x 134 mm (with conduit hub cULus version) 247 mm x 257 mm x 134 mm (with cable glands - non cULus version) 290 mm x 300 mm x 165 mm (in cardboard box)
Weight net (gross)	approx. 1.7 kg (cULus version 2.5 kg)
Protection class	IP65 (not UL evaluated)
<b>Enclosure (B850-P-2)</b>	
Enclosure type	Panel mounting, Lexan Resin 920 material
Dimensions (height x width x depth)	110 mm x 206 mm x 63.5 mm (without terminals) 110 mm x 206 mm x 72 mm (with terminals) 135 mm x 230 mm x 110 mm (in cardboard box)
Panel cut-out dimensions	186 mm x 92 mm
Panel thickness	1 .. 5 mm
Weight net (gross)	approx. 0.6 kg (0.7 kg)
Protection class (front / rear)	IP65 / IP20 (not UL evaluated)
<b>Environmental conditions</b>	
Ambient temperature	0 .. +55 °C (32 .. 131 °F)
Relative humidity	5 .. 95% (non-condensing)
Altitude	≤ 2000 m (6 562 ft) above sea level
Storage temperature	-30 .. +70 °C
Pollution degree	3 Panel version (when installed in an enclosure) 3 Wall version
Electrical safety	EN 61010-1 UL 61010-1, 3rd Edition CAN/CSA-C22.2 No. 61010-1, 3rd Edition
EMC	Immunity EN 61326-1 Table 2 Radiated and conducted emissions EN61326-1 Group 1 Class B
Installation location	Indoor use only

## Dimensions / weights (approximate) in mm and kg

B850	A	B	C	D	E	Weight
B850-W-2 (wall mounted)	257	217	134	30*	-	1.70
B850-W-2-UL (wall mounted)	257	217	134	21	-	2.5
B850-P-2 (panel mounted)	206	110	72.3	-	9.5	0.60

\* Approximate dimension as the cable glands are adjustable.

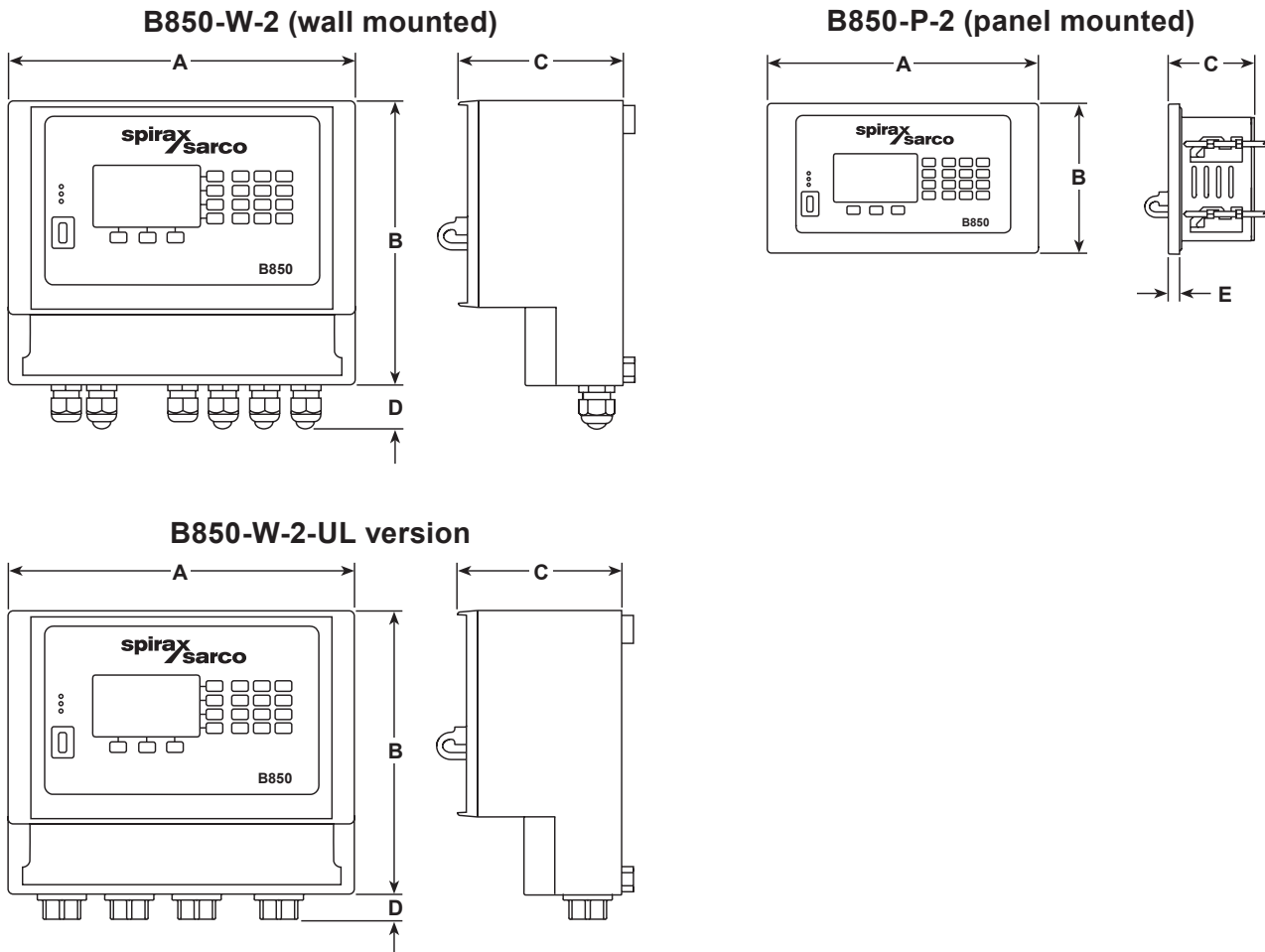

## Safety information, installation and maintenance

For full details see the Installation and Maintenance Instructions supplied with the product.

### Installation notes:

1. The wall mounted B850-W requires 3 mounting screws (not supplied) to mount to a wall or has optionally a DIN rail mounting.
2. The panel mounted B850-P is supplied with mounting clamps.

### Disposal

This product is recyclable. No ecological hazard is anticipated with the disposal of this product, provided due care is taken.

## How to order

For the correct product nomenclature for the unit that best suits the intended application please revisit page 2 'Available options' before placing an order.

**Example 1:** 1 off B850-P-2 panel mounted energy monitor with two analog 4-20 mA outputs, 24 Vdc supply

**Example 2:** 1 off M850-W-2-UL wall mounted energy monitor with two analog 4-20 mA outputs, 240 Vac supply

## Spare parts

There are no spare parts available for the B850 energy monitors.