



AVS32

Stainless Steel Air Vent for Steam Systems

Description

The AVS32 is a stainless steel maintainable balanced pressure thermostatic air vent for use on steam systems. It has an integral flat strainer screen and straight connections. All pressure bearing components are produced by TÜV approved suppliers in accordance with AD-Merkblatt WO/TRD100.

Standards

This product fully complies with the requirements of the European Pressure Equipment Directive 97/23/EC.

Certification

This product is available with certification to EN 10204 3.1.B.

Note: All certification/inspection requirements must be stated at the time of order placement.

Sizes and pipe connections

½", ¾" and 1" screwed BSP or NPT.

½", ¾" and 1" socket weld ends to BS 3799.

½", ¾" and 1" butt weld ends to EN 12 627.

DN15, DN20 and DN25 standard flange to EN 1092 PN40, ANSI B 16.5 Class 150 and 300, JIS/KS 10K and JIS/KS 20K.

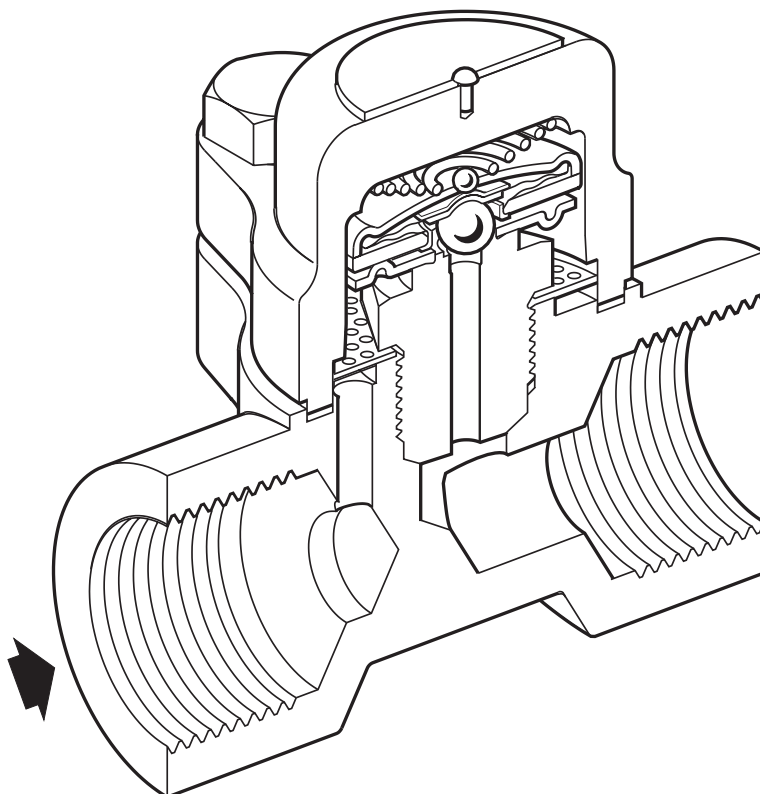

Pressure/temperature limits (ISO 6552)

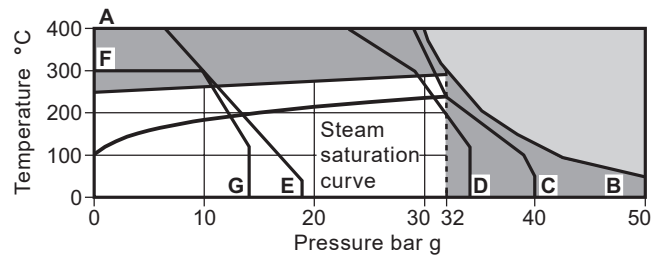

 The product **must not** be used in this region.

 The product should not be used in this region or beyond its operating range as damage to the internals may occur.

A - B Screwed, socket weld, butt weld and flanged ANSI 300.

A - C Flanged JIS/KS 20K.

A - D Flanged ASME (ANSI) 150.

A - E Flanged ANSI 150.

F - G Flanged JIS/KS 10K.

| | |
|---|-------------------|
| Body design conditions | PN40 |
| PMA Maximum allowable pressure | 50 bar g @ 50 °C |
| TMA Maximum allowable temperature | 400 °C @ 30 bar g |
| Minimum allowable temperature | -200 °C |
| PMO Maximum operating pressure for saturated steam service | 32 bar g |
| TMO Maximum operating temperature | 287 °C @ 32 bar g |
| Minimum operating temperature | 0 °C |
| Note: For lower operating temperatures consult Spirax Sarco. | |
| Designed for a maximum cold hydraulic test pressure of | 75 bar g |

K_v values

| Size | DN15 - ½" | DN20 - ¾" | DN25 - 1" |
|----------------------|-----------|-----------|-----------|
| K_v | 0.8 | 0.8 | 0.8 |

For conversion:

C_v (UK) = $K_v \times 0.963$

C_v (US) = $K_v \times 1.156$

Materials

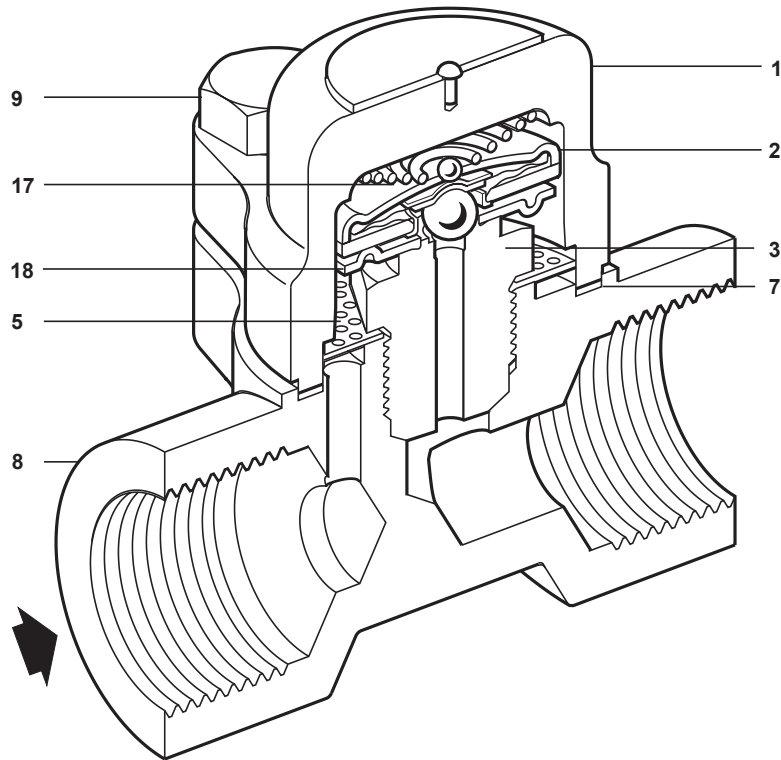

| No. | Part | Material | |
|-----|-----------------|--|------------------------------|
| 1 | Cover | Austenitic stainless steel | DIN 17440 (W/S 1.4571) 316Ti |
| 2 | Capsule | Stainless steel | |
| 3 | Valve seat | Stainless steel | BS 970 431 S29 |
| 5 | Strainer screen | Stainless steel | AISI 304 |
| 7 | Cover gasket | Stainless steel reinforced exfoliated graphite | |
| 8 | Body | Austenitic stainless steel | DIN 17440 (W/S 1.4571) 316Ti |
| 9 | Cover bolts | Stainless steel (M10 x 30) | A2-70 |
| 17 | Spring | Stainless steel | |
| 18 | Spacer plate | Stainless steel | |

Dimensions/weights (approximate) in mm and kg

| Size | A | A1 | B | C | D | E | Weight | |
|---------|----|-----|----|----|----|----|------------|------|
| | | | | | | | Scrd/SW/BW | Flgd |
| ½" DN15 | 95 | 150 | 94 | 64 | 17 | 37 | 1.4 | 2.9 |
| ¾" DN20 | 95 | 150 | 94 | 64 | 19 | 37 | 1.4 | 3.5 |
| 1" DN25 | 95 | 160 | 94 | 64 | 23 | 37 | 1.5 | 4.1 |

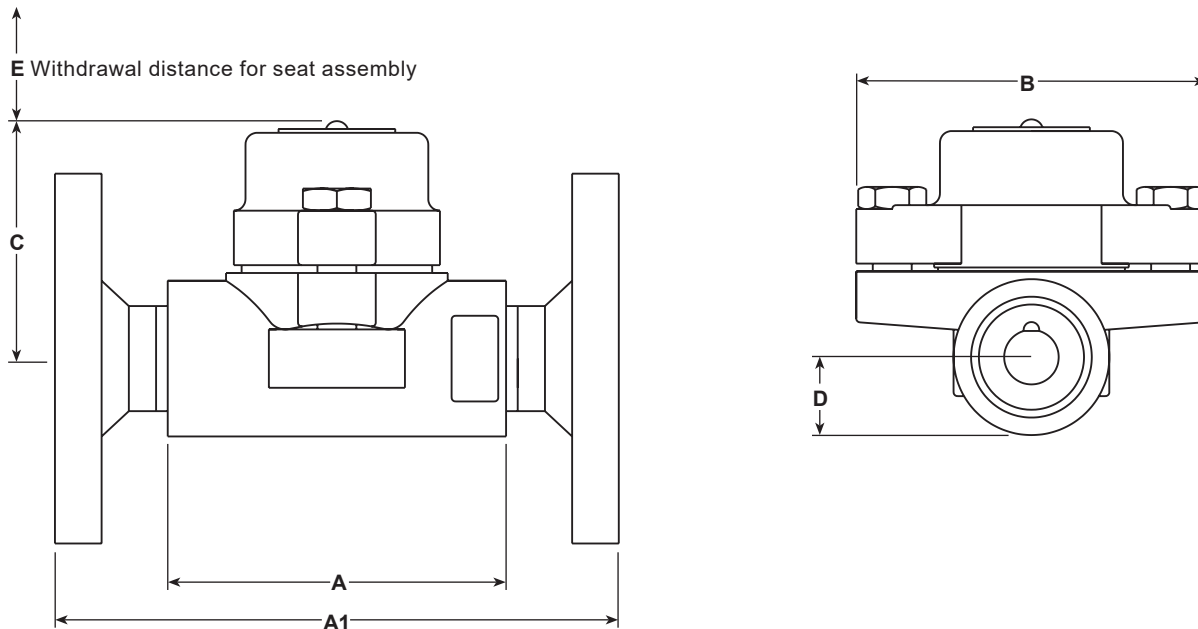

Safety information, installation and maintenance

For full details see the Installation and Maintenance Instructions (IM-P123-17) supplied with the product.

Installation note:

The AVS32 is designed for installation with the capsule in a horizontal plane with the cover at the top.

The AVS32 should be positioned at the highest point of the steam main or plant where the air collects. The outlet should be piped to a safe place.

For ease and maintenance, consideration should be given to fitting isolation valves upstream and downstream of the air vent.

The air vent must not be insulated.

Disposal

This product is recyclable. No ecological hazard is anticipated with the disposal of this product, providing due care is taken.

How to order

Example: 1 off Spirax Sarco ½" AVS32 air vent having screwed BSP connections.

Spare parts

The spare parts available are shown in solid outline. Parts drawn in broken line are not supplied as spares.

Available spares

| | |
|------------------------------------|--------------|
| Capsule and seat assembly set | 2, 3, 17, 18 |
| Strainer screen (packet of 3) | 5 |
| Set of cover gaskets (packet of 3) | 7 |



How to order spares

Always order spares by using the description given in the column headed 'Available spares' and state the size and type of air vent.

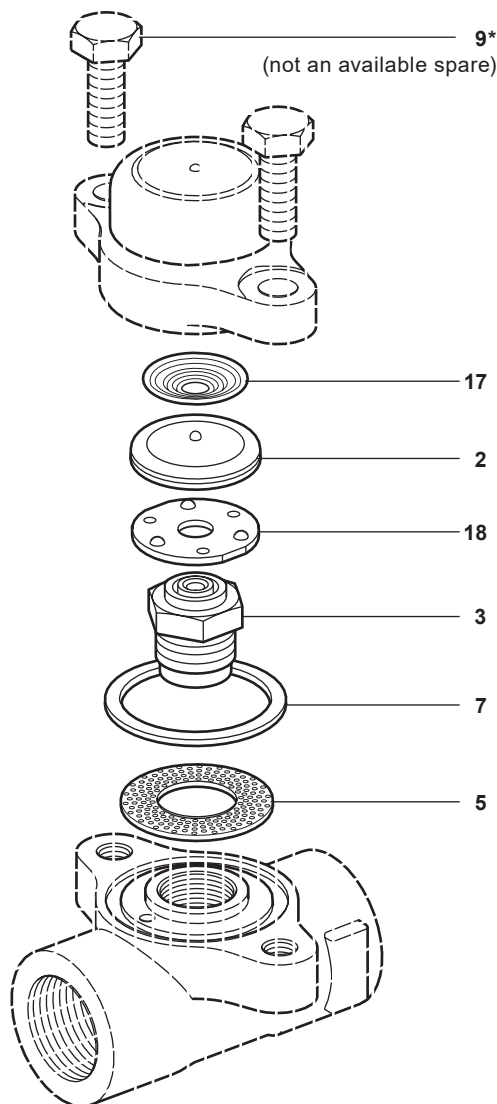
Example: 1 - Capsule and seat assembly set for a Spirax Sarco DN25 AVS32 air vent.



Recommended tightening torques

| Item | Part |  or mm |  | N m |
|------|-------------|--|---|-----------|
| 3 | Valve seat | 24 A/F | | 115 - 125 |
| 9 | Cover bolts | 16 A/F | M10 x 30 | 23 - 27 |