



TI-P680-01
 ST Issue 2

APT10-PPU, APT14-PPU and APT14HC-PPU (Closed System) Automatic Pump-trap Packaged Units

Description

The Spirax Sarco APT10-PPU, APT14-PPU and APT14HC-PPU automatic pump-trap packaged units are plug in systems specifically designed to remove condensate from plant under 'stall' conditions. The whole system is capable of handling capacities up to 2800 kg/h pumping and 9000 kg/h trapping, depending on available differential pressure.

Each unit comes with a condensate receiver, motive supply drain trap and ancillaries.

Operated by steam the APT10, APT14 and APT14HC-PPU's meet a wide range of applications. The standard pump-trap is manufactured from SG iron, although electroless nickel plated (ENP) versions are available on request.

Standards

These products fully comply with the requirements of the European Pressure Equipment Directive 97/23/EC and carry the CE mark. All welding is in accordance with ASME IX, BS EN 287/288, BS EN part 1-2004 and BS EN ISO 15614 part 1-2004.

Certification

These products are available with a Declaration of Conformity. Other certification is available for individual component parts if required, at extra cost. **Note:** All certification/inspection requirements must be stated at the time of order placement.

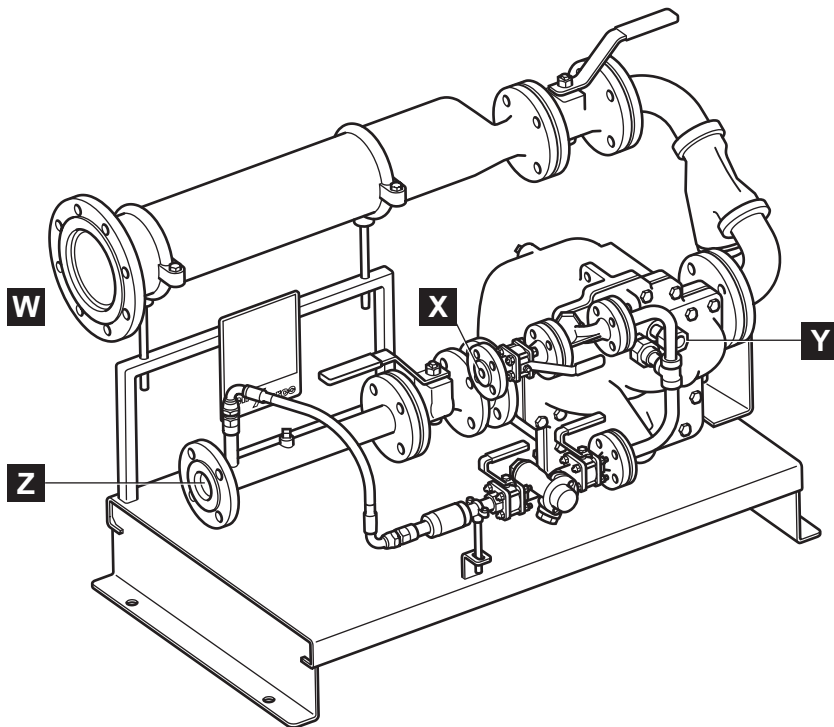

Sizes and pipe connections

Unit size			W Condensate inlet	X Motive supply	Y Exhaust/ balance line	Z Condensate outlet
APT10-PPU	DN20 x DN20 (3/4" x 3/4")	PN16	DN65	DN15	DN15	DN20
APT14-PPU	DN40 x DN25 (1 1/2" x 1")	PN16	DN100	DN15	DN15	DN25
APT14HC-PPU	DN50 x DN40 (2" x 1 1/2")	PN16	DN125	DN15	DN15	DN40

W2

Connects to the system pipework

W1

Connects to flange W of the unit

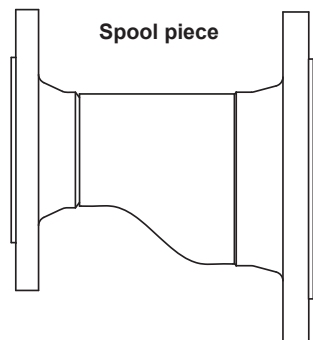

Optional extras

A spool piece is available to connect the receiver to the system pipework.

Limiting conditions

Unit design conditions	APT10	PN10
	APT14 and APT14HC	PN16
Maximum motive inlet pressure (steam)	APT10	4.5 bar g
	APT14 and APT14HC	13.8 bar g
Maximum operating pressure	APT10	4.5 bar g
	APT14 and APT14HC	13.8 bar g
Maximum backpressure	APT10	4 bar g
	APT14 and APT14HC	5 bar g
Maximum operating temperature	APT10	155°C
	APT14 and APT14HC	198°C
Minimum operating temperature		0°C
Designed for a maximum cold hydraulic test pressure of:	APT10	15 bar g
	APT14 and APT14HC	24 bar g

Note: For operating temperatures above or below those stated contact Spirax Sarco.

Capacities

Sizing of the pump-trap is dependent on motive pressure, backpressure (lift, return system pressure and frictional losses) and process conditions. For accurate sizing for the application please contact Spirax Sarco.

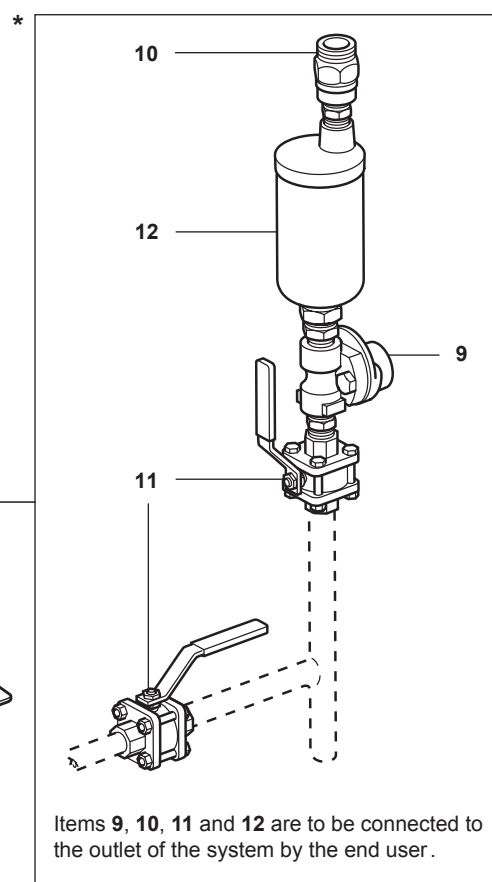
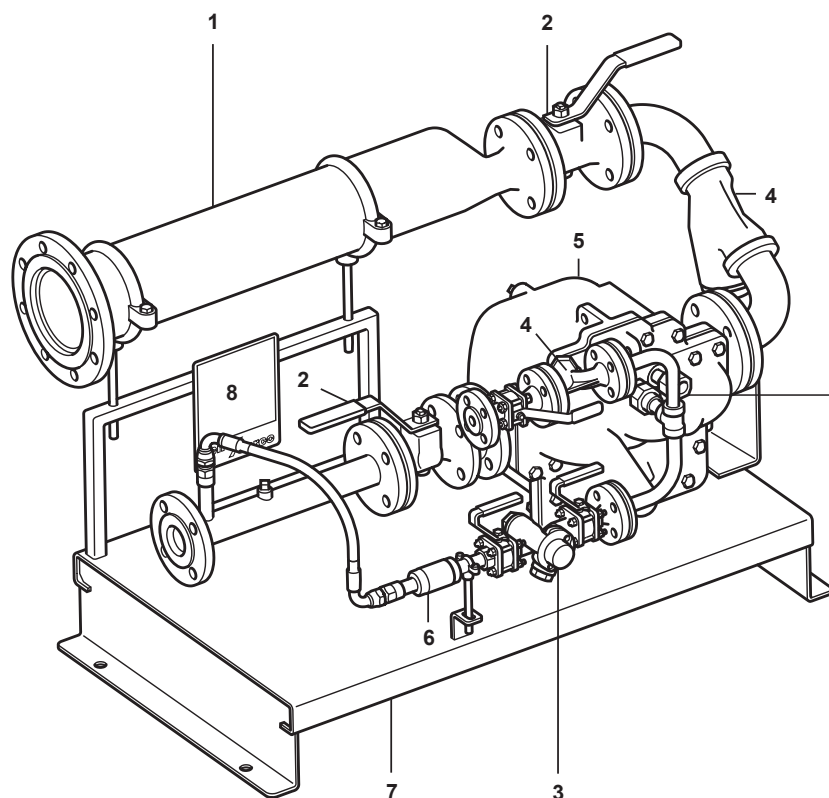

Materials

No.	Part			Material	
1	Receiver			Carbon steel	
2	Ball valves	DN20 to DN50	(¾" to 2")	Steel (PTFE seals)	
3	Trap set	DN15	(½")	Stainless steel (PTFE seals)	STS17.2
4	Strainer	DN15 to DN50	(½" to 2")	SG iron	
5	Pump-trap			SG iron	
6	Diffuser			Stainless steel	
7	Base and supporting frame			Carbon steel	
8	Name-plate			Aluminium	
* 9	Air vent			Stainless steel	PC10HP / UBP32
* 10	Check valve			Stainless steel	
* 11	Ball valve	DN15	(½")	Stainless steel	
* 12	Air eliminator			Austenitic stainless steel	AE50S

* **Please note:** Items 9, 10, 11 and 12 are not included with the pump package. They must be ordered as a separate item. It is intended that the end user provides the pipework and connects these components correctly - see Section 3 'Installation' of the Installation and Maintenance Instructions (IM-P680-02) supplied with the unit.

APT - Dimensions/weights (approximate) in mm and kg

Unit size	A	B	C	D	E	F	G	H	I	J	K	L	M	N	Weight
DN20 x DN20 (¾" x ¾")	642	428	228	1024	1081	588	600	549	428	110	253	795	375	-	110
DN40 x DN25 (1½" x 1")	657	528	353	1064	1081	723	600	547	400	285	320	755	282	244	170
DN50 x DN40 (2" x 1½")	743	553	353	1215	1081	787	600	618	425	250	400	833	322	253	220

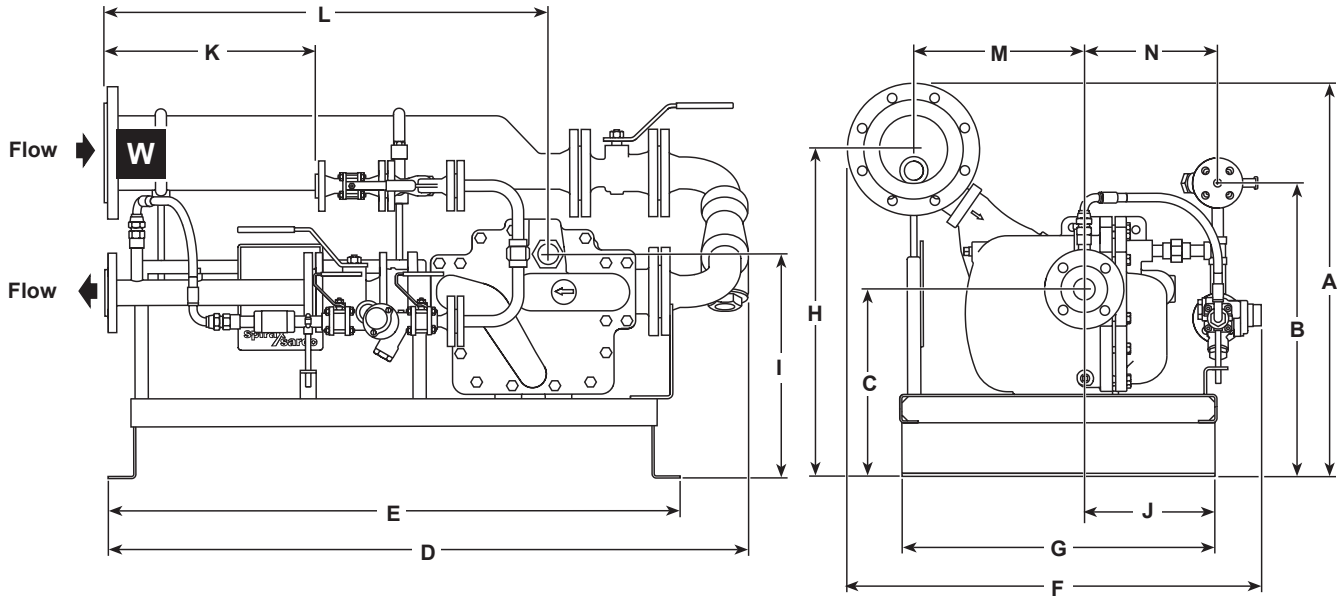

Spool piece - Dimensions (approximate) in mm

Unit size	W1	W2	O	P
DN20 x DN20	DN65	DN25	173	20
		DN40	176	13
		DN50	180	7
DN40 x DN25	DN100	DN40	196	31
		DN50	201	26
		DN65	199	19
DN50 x DN40	DN125	DN50	227	41
		DN65	227	33
		DN80	232	24
		DN100	234	13

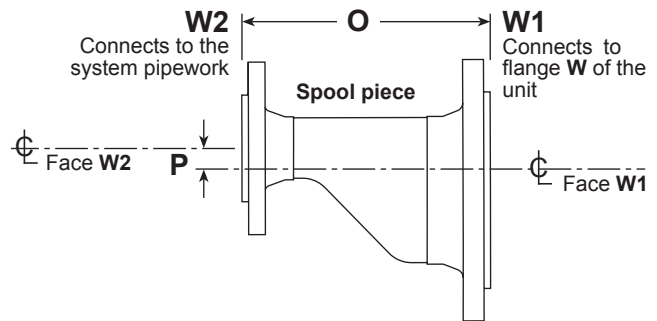

Safety information, Installation and maintenance

For full details see the Installation and Maintenance Instructions supplied with the unit.

For full details of the individual component products see separate Installation and Maintenance Instructions also supplied with the unit.

Spare parts

Either refer to the individual component product Technical Information sheets (TI) or Installation and Maintenance Instructions (IM) supplied with the unit, for availability of spare parts.

How to specify

Spirax Sarco APT14-PPU (APT10-PPU or APT14HC-PPU) closed system automatic pump-trap packaged unit, operated by steam up to 13.8 bar g (4.5 bar g for the APT10-PPU). The complete system shall be supplied with PED markings, with all welding in accordance with BS EN 287/288.

How to order example

1 off Spirax Sarco DN40 x DN25 APT14-PPU (closed system) automatic pump-trap packaged unit with flanged PN16 external connections plus the optional DN100 x DN40 spool piece.

+

1 off Spirax Sarco air vent kit for APT14-PPU.