

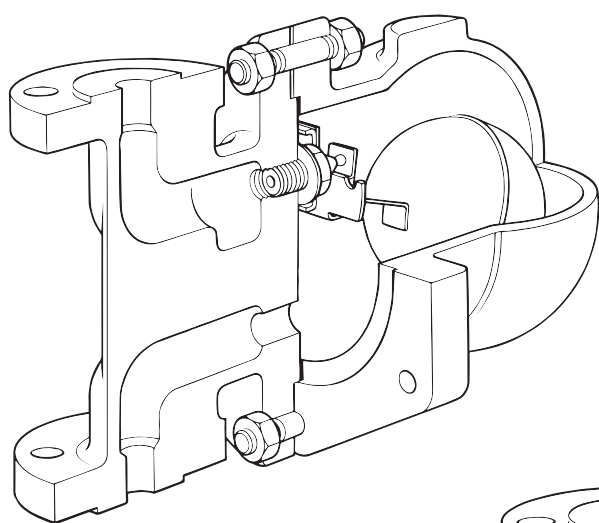

AE44 and AE44S Automatic Air and Gas Vents for Liquid Systems

Description

The AE44 and AE44S are float type automatic air and gas vents for liquid systems. The body and cover are of steel and the valve cone is available in synthetic rubber designated AE44 or in stainless steel designated AE44S. Body and cover castings are produced by a TÜV approved foundry.



Available types

AE44	Steel body and cover. Valve cone in synthetic rubber.
AE44S	Steel body and cover. Valve cone in stainless steel.

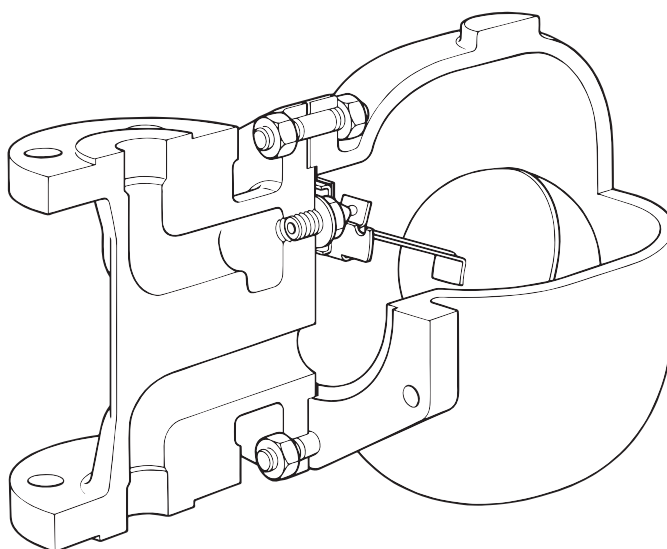

Certification

This product is available with a Manufacturer's Typical Test Report for the body and cap as standard and certification to EN 10204 3.1 if specified at time of ordering.

Sizes and pipe connections

AE44 DN15 and DN20, AE44S DN15, DN20 and DN25.

Standard flanges are EN 1092 PN40 with DIN face-to-face dimensions. On request ASME 150, ASME 300 and JIS/KS 20 flanges with drilled and tapped bolt holes with DIN face-to-face dimensions can be provided. The 1/2" tapping for the balance pipe will normally be screwed NPT for ASME and JIS/KS flanges and BSP T Rp (ISO 7-1) for other flanges unless specified otherwise.

Materials

DN15 and DN20

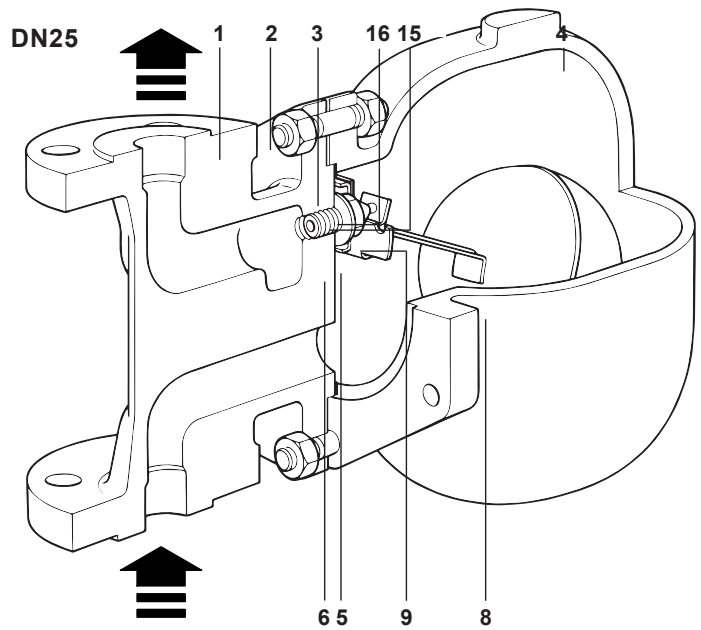
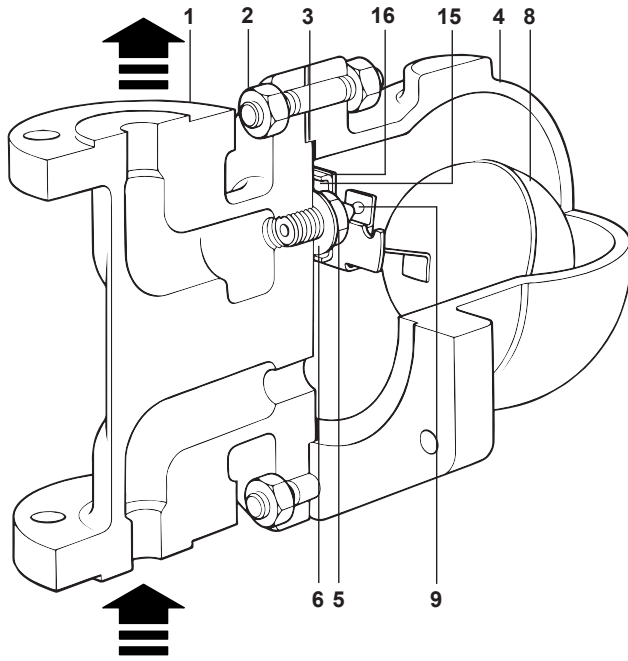

No.	Part	Material	
1	Body	Carbon steel	ASTM A216 WCB/BS EN 10213 GP240GH +N
2	Cover studs	Chrome moly steel	DIN 17240 21Cr MoV57
	Cover nuts	Chrome moly steel	EN 10269 25 Cr Mo 4
3	Cover gasket	Reinforced exfoliated graphite	
4	Cover	Carbon steel	ASTM A216 WCB/BS EN 10213 GP240GH +N
5	Valve seat	Stainless steel	BS 970 431 S29
6	Valve seat gasket	Stainless steel	BS 1449 304 S11
7	Pivot frame assy.set screws (not shown)	Stainless steel	BS 4183 18/8
8	Ball float and lever	Stainless steel	BS 1449 304 S16
9	Valve cone	AE44	Viton
		AE44S	Stainless steel
15	Support frame	Stainless steel	BS 1449 304 S16
16	Pivot frame	Stainless steel	BS 1449 304 S16
17	Pivot (not shown)	Stainless steel	

Note: The valve cone AE44S is permanently attached to the ball float and lever.

Pressure/temperature limits

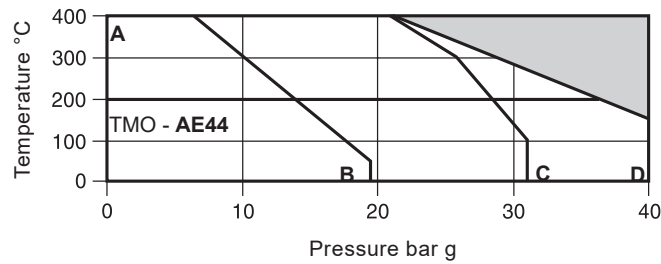

The product **must not** be used in this region.

A - B ASME 150.

A - C JIS/KS 20

A - D PN40, ASME 300

Body design conditions		PN40
PMA	Maximum allowable pressure	40 bar g
TMA	Maximum allowable temperature	400 °C
TMO	Maximum operating temperature	AE44
		AE44S
Product is safe for use under full vacuum conditions		
	ASME 150	30 bar g
Designed for a maximum cold hydraulic test pressure of:	JIS/KS 20	49 bar g
	PN40/ASME 300	60 bar g

Note: For lower operating temperatures consult Spirax Sarco.

ΔPMX - Maximum differential pressures

AE44	DN15	21 bar
AE44S-21	DN15	21 bar
AE44	DN20	21 bar
AE44S-21	DN20	21 bar
AE44S-3.5	DN25	3.5 bar
AE44S-5.3	DN25	5.3 bar
AE44S-7.8	DN25	7.8 bar
AE44S-16.7	DN25	16.7 bar

The automatic air and gas vent in its complete operational form must not be subjected to a pressure greater than 48 bar g otherwise damage to the mechanism may result.

Capacities

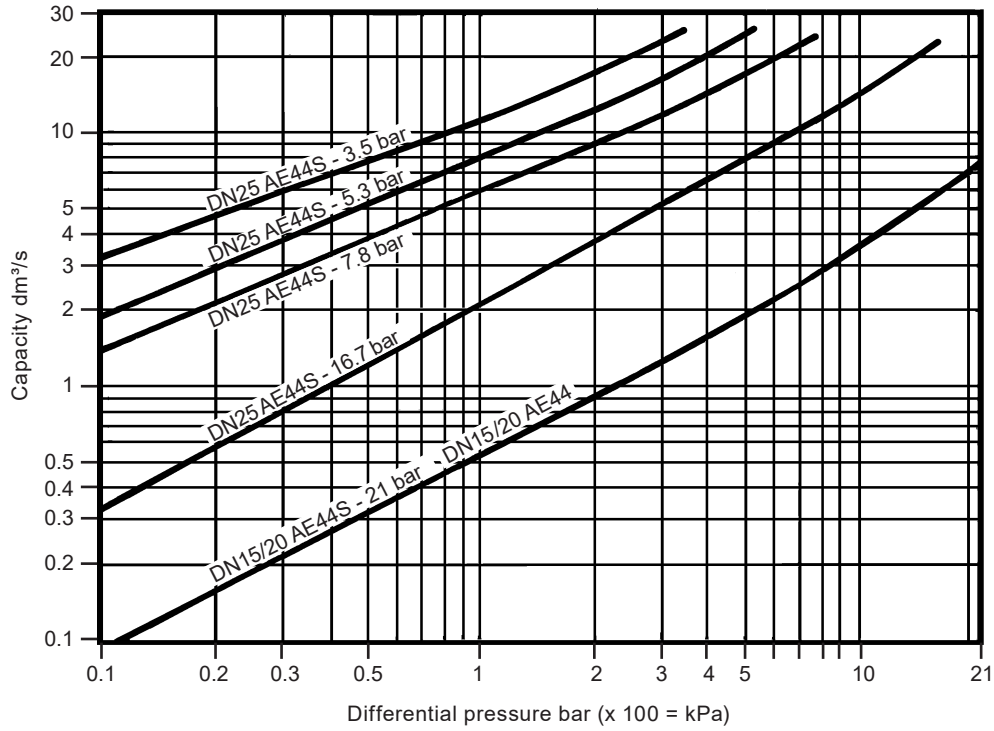

Hot water capacity ———

Free air discharge capacity

If the temperature of the air differs from 15 °C, the discharge capacity from the graph can be corrected by multiplying it by the following equation:

$$\frac{289}{273 + T} \quad (T \text{ is the actual temperature})$$

It may be assumed that the temperature of the air is the same as the temperature of the water.

Dimensions/weights (approximate) in mm and kg

DN15 and DN20

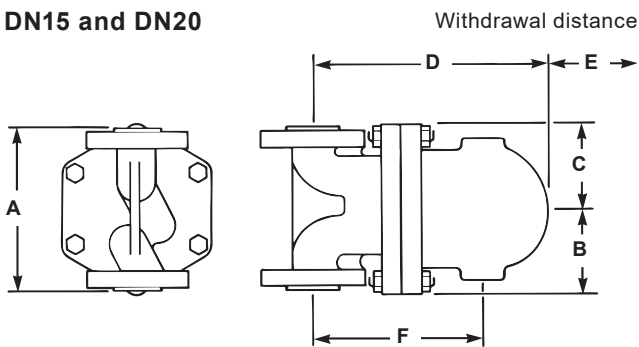

DN25

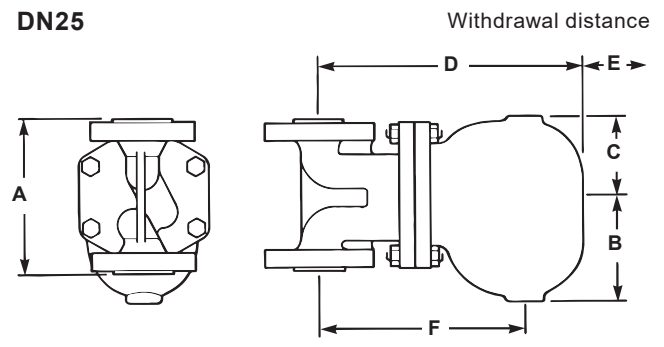

Size	A	B	C	D	E	F	Weight
DN15	150	80	80	215	120	155	10.8
DN20	150	80	80	225	120	165	10.8
DN25	160	115	85	282	170	215	15.0

Flange bolt hole tapings

Size	ASME 150	ASME 300	JIS/KS 20
DN15	1/2" - 13 UNC - 2B	1/2" - 13 UNC - 2B	M12
DN20	1/2" - 13 UNC - 2B	5/8" - 11 UNC - 2B	M12
DN25	5/8" - 11 UNC - 2B	5/8" - 11 UNC - 2B	M16

Safety information, installation and maintenance

Installation note:

The automatic air and gas vent must be fitted into a vertical pipeline above the point being vented with the direction of flow upward as indicated on the body so that the float mechanism is free to rise and fall in a vertical plane. The arrow on name-plate must point downwards. The low point of the cover is provided with a 1/2" tapping for a balance pipe which is essential for satisfactory operation. The balance pipe must be connected between the inlet pipe and the tapping provided on the cover as shown in the sketch below.

As with all automatic air vents, dribbling may occur if the valve becomes fouled with dirt. For this reason it is recommended that a drip pipe is fitted to the outlet discharging to a safe place.

Maintenance

Servicing: With suitable isolation, repairs can be carried out with the vent in line. Undo cover studs and nuts and lift off cover. When reassembling make sure that all joint faces are clean. Always use a new gasket. Tighten cover studs and nuts uniformly. Open up isolating valve.

Note: on reassembly make sure that the dowel is located into the body.

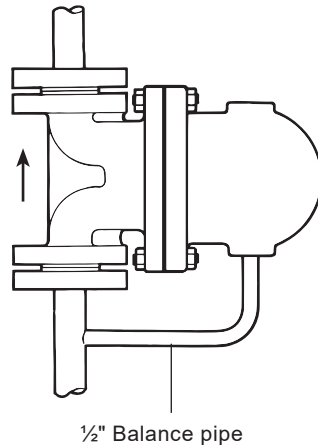

How to order

Example: 1 off Spirax Sarco DN20 AE44 automatic air and gas vent with steel body and Viton valve head flanged to EN 1092 PN40.

Spare parts

The spare parts available are shown in solid outline. Parts drawn in grey lines are not supplied as spares.

Available spares

Soft valve cone AE44	(packet of 3 of each)	9
Main valve assembly with float	AE44	5, 6, 7, 8, 9, 15, 16, 17
	AE44S	5, 6, 7, 8, 15, 16, 17
Complete set of gaskets	(packet of 3 sets)	3, 6



How to order spares

Always order spares by using the description given in the column headed 'Available spares' and state the size and type of automatic air and gas vent.

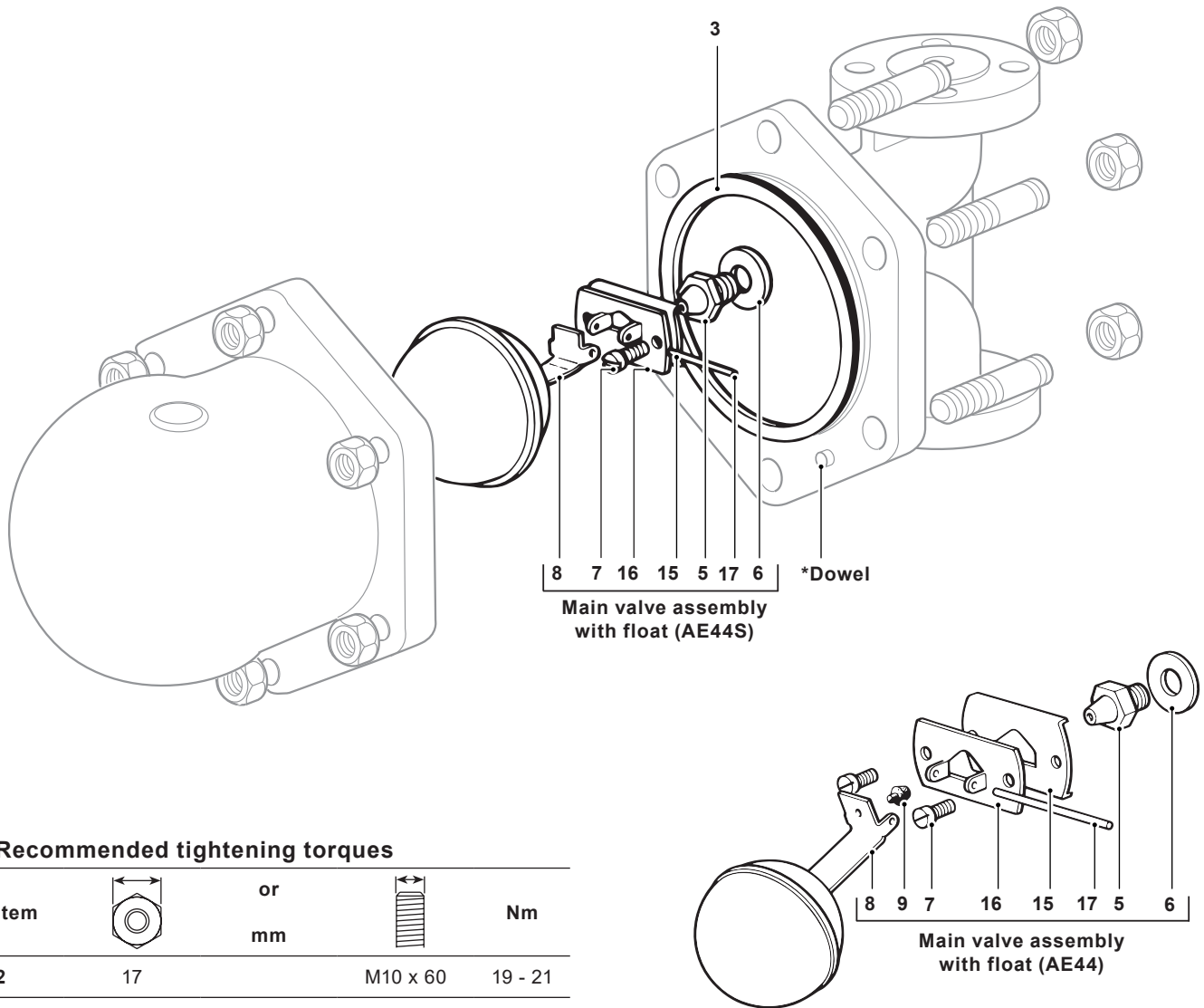
Example: 1 - Main valve assembly for a Spirax Sarco DN20 AE44 automatic air vent.



Recommended tightening torques

Item		or mm		Nm
2	17		M10 x 60	19 - 21
5	17		M12 x 8	50 - 55
7	Cheesehead		M5 x 20	2.5 - 2.8