



AE10S High Capacity Automatic Air and Gas Vent for Liquid Systems

Description

The AE10S is a high capacity float type automatic air and gas vent for liquid systems and is readily maintainable. The body and cover are of cast iron and the valve and seat of stainless steel.

Standards

This product fully complies with the requirements of the European Pressure Equipment Directive 2014/68/EU.

Certification

The product is available with certification to EN 10204 2.2 for body and cover as standard.

Note: All certification/inspection requirements must be stated at the time of order placement.

Sizes and pipe connections

3/4" screwed BSP T Rp (ISO 7-1) or NPT.

Pressure/temperature limits

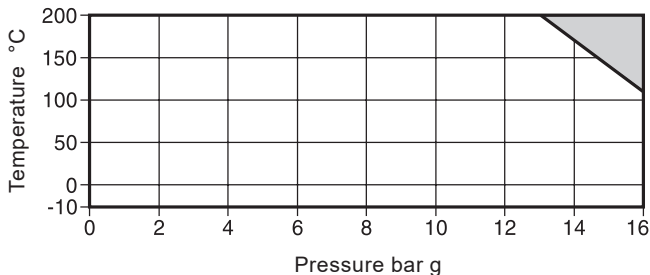

 The product **must not** be used in this region.

Body design conditions	PN16
PMA Maximum allowable pressure	16 bar g @ 110 °C
TMA Maximum allowable temperature	200 °C
Minimum allowable temperature	-10 °C
PMO Maximum operating pressure	16 bar g @ 110 °C
TMO Maximum operating temperature	200 °C @ 13 bar g
Minimum operating temperature	-10 °C
ΔPMX Maximum differential pressure	6 bar
Designed for a maximum cold hydraulic test pressure of 24 bar g	
Minimum specific gravity of liquid	0.6

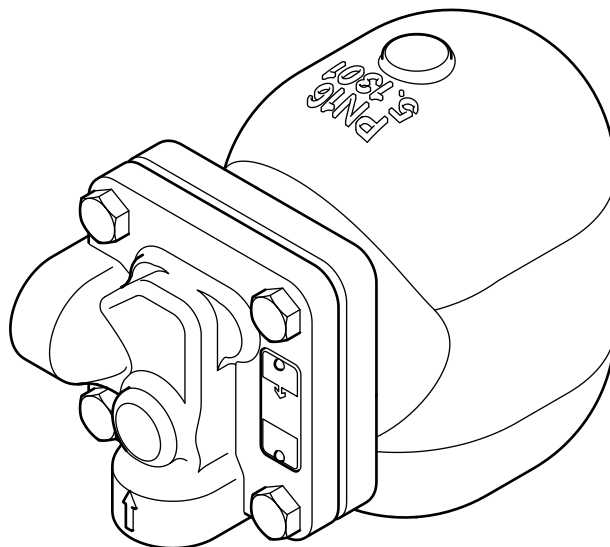

Materials

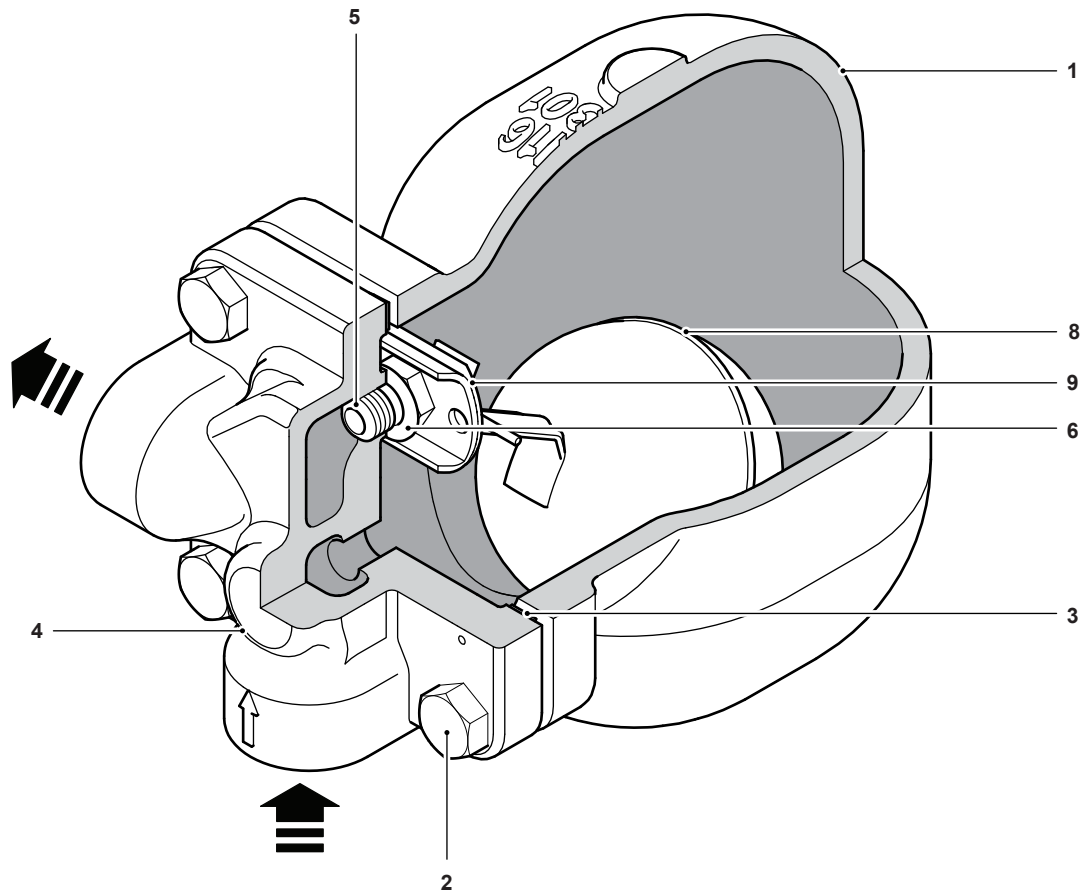

No.	Part	Material	
1	Body	Cast iron	EN-GJL-250 (5.1301)
2	Cover bolts	Steel	BS3692 Gr.8.8
3	Cover gasket	Reinforced exfoliated graphite	
4	Cover	Cast iron	EN-GJL-250 (5.1301)
5	Valve seat	Stainless steel	BS 970 431 S29
6	Valve seat gasket	Stainless steel	BS 1449 304 S11
7	Pivot frame assembly set screws (shown on Available spares drawing)	Stainless steel	BS 4183 18/8
8	Ball float and lever	Stainless steel	BS 1449 304 S16
9	Valve cone		
9	Note: The valve cone is permanently attached to the ball float and lever mechanism. (shown more clearly on the Available spares drawing)	Stainless steel	AISI 440B
15	Support frame (shown on Available spares drawing)	Stainless steel	BS 1449 304 S16
16	Pivot frame (shown on Available spares drawing)	Stainless steel	BS 1449 304 S16
17	Pivot (shown on Available spares drawing)	Stainless steel	

Dimensions/weight
(approximate) in mm and kg

Size	A	B	C
3/4"	60	111	77

Size	D	E	F
3/4"	195	165	118

Size	G	H	Weight
3/4"	50	217	6.8

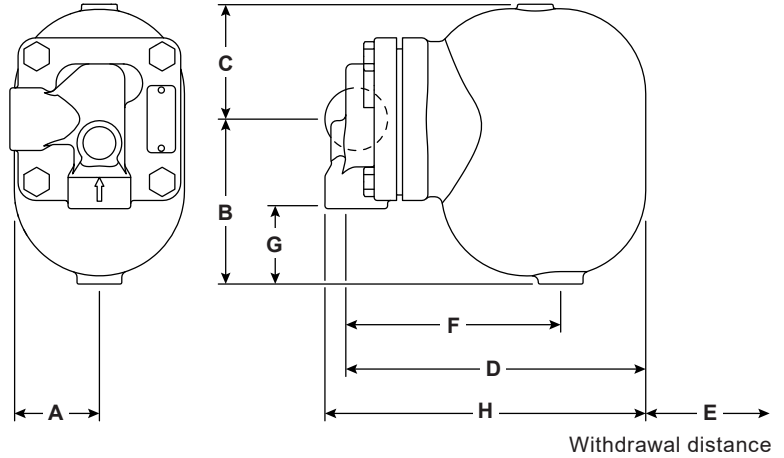

Free air discharge capacity

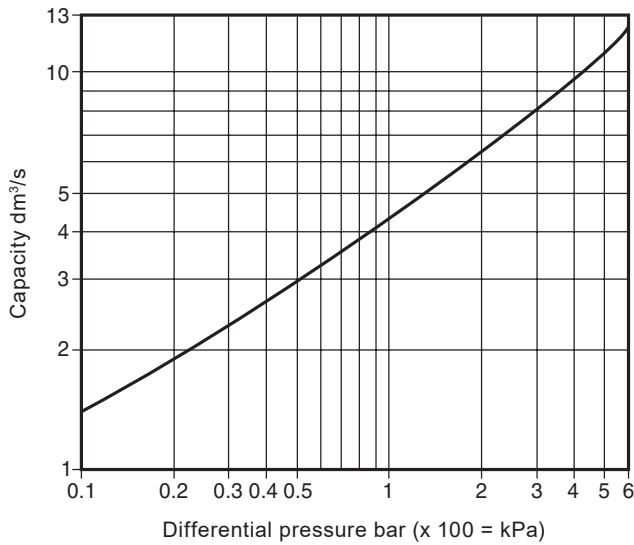

If the temperature of the air differs from 15 °C, the discharge capacity from the graph can be corrected by multiplying it by the following equation:

$$\frac{289}{273 + T} \quad (T \text{ is the actual temperature in } ^\circ\text{C})$$

It may be assumed that the temperature of the air is the same as the temperature of the water.

Safety information, installation and maintenance

For full details see the Installation and Maintenance Instructions (IM-P149-13) supplied with the product.

Installation note:

The 3/4" AE10S high capacity automatic air vent must always be fitted with the inlet at the bottom so that the float mechanism is rising and falling in a vertical plane. From the tapping provided at the low point of the cover, a 1/2" balance pipe having continuous rise towards the automatic air vent must be fitted and connected into the inlet pipework (as shown in the sketch) which is essential for satisfactory operation.

Because of the way automatic air and gas vents operate they all dribble water and liquid when discharging air and gas. This is perfectly normal. Spirax Sarco recommend piping the discharge to a safe visible point or drain via an air break.

Maintenance note:

With suitable isolation, repairs can be carried out with the automatic air vent in line.

Disposal

The product is recyclable. No ecological hazard is anticipated with disposal of this product, providing due care is taken.

How to order

Example: 1 off Spirax Sarco 3/4" screwed BSP AE10S high capacity automatic air and gas vent with cast iron body and stainless steel valve and seat.

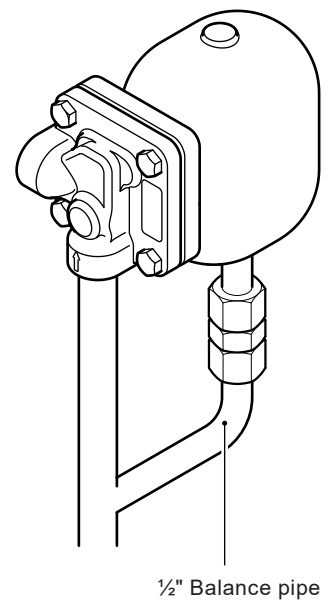

Spare parts

The spare parts available are shown in heavy outline. Parts drawn in a grey line are not supplied as spares.

Available spares

Main valve assembly with float	5, 6, 7, 8, 9, 15, 16, 17
Three complete sets of gaskets (packet of 3 sets)	3, 6



How to order spares

Always order spares by using the description given in the column headed 'Available spares' and state the size and type of automatic air vent.

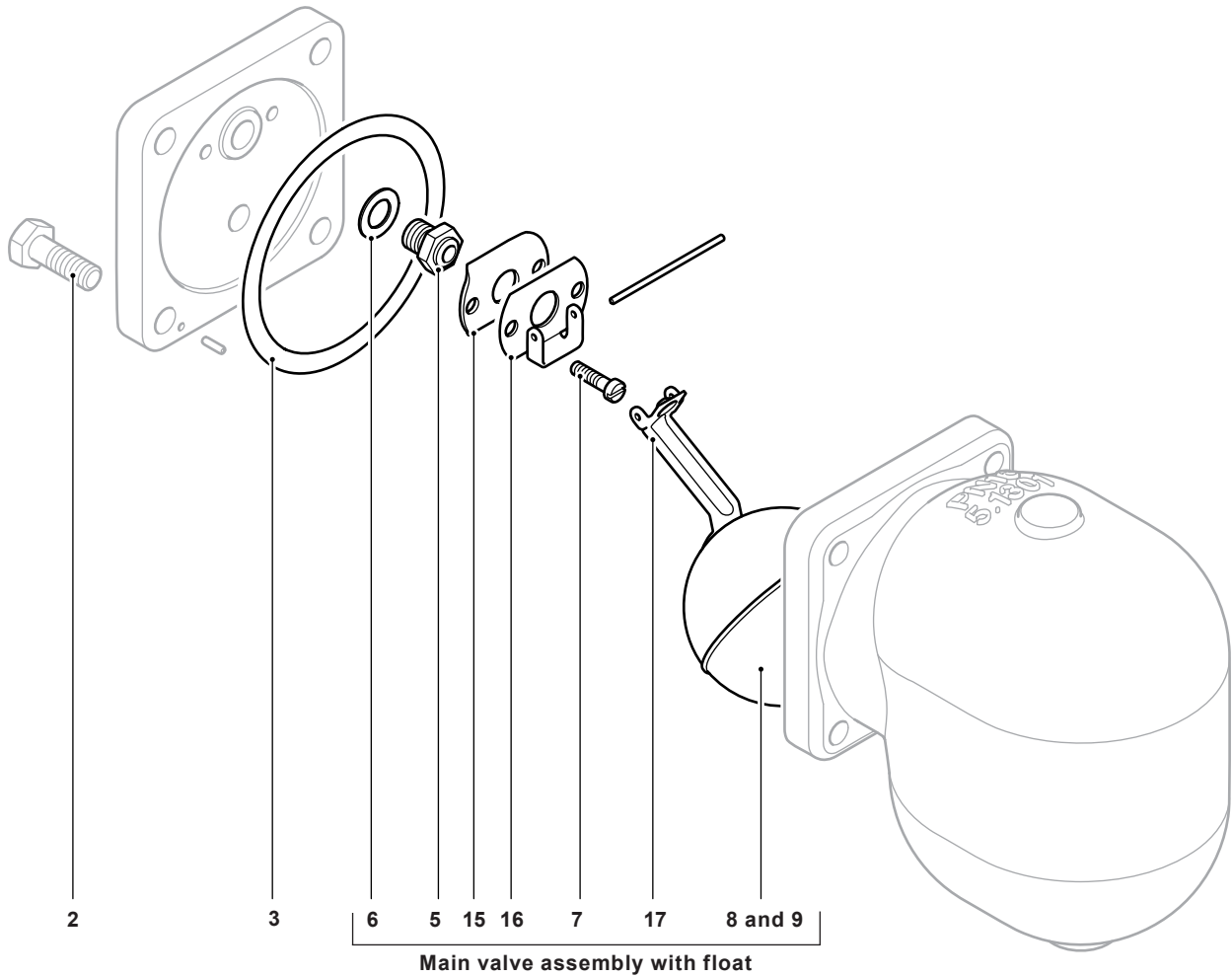
Example: 1 - Main valve assembly for a Spirax Sarco ¾" AE10S high capacity automatic air and gas vent.



Recommended tightening torques

Item	 17	or mm		N m
2	17		M10 x 30	29 - 32
5	17		M12 x 8	50 - 55
7			M5 x 20	2.5 - 2.8