



Cert. No. LRQ 0963008

ISO 9001

spirax sarco

ADV

TI-P509-06
CH Issue 3

Spirax-Monnier Automatic Drain Valve

Description

The Spirax-Monnier ADV automatic drain valve has been designed to remove condensate from any low points in a compressed air system where automatic drainage should be provided. Condensate is a mixture of water, oil and dirt, with the thickness or viscosity increasing with low temperatures.

Principal features:

- Variable discharge frequency.
- Variable discharge time.
- Low power consumption.
- LED showing operational status.
- Reliable, long life, solid state timers.
- Manual test facilities.
- Minimal maintenance.
- Simple installation.

Applications

The Spirax-Monnier ADV automatic drain valve can be installed at any low point in a compressed air system where condensate forms or is collected. These include after coolers, separators, receivers, large filter units and drain legs, etc. TI-P509-07 gives examples of typical installations.

Sizes and pipe connections

¼", ⅜" and ½" screwed BSP.

Optional extras:

- Solenoid valve.
- DIN connector.

Technical data

Operating temperature range	Ambient temperature	-10°C > +50°C	
	Media temperature	-10°C > +130°C	
Mains voltage / pressure	230 Vac	50 Hz	16 bar
	110 Vac	50 Hz	16 bar
	120 Vac	60 Hz	16 bar
Discharge time variable	0.5 to 10 seconds		
Discharge frequency variable	0.5 to 45 minutes		
Connector	DIN 43650 - ISO 4400/6952		
Insulation	Class F (155°C)		
Enclosure	IP65		

Conforms to E.U. directives on low voltage and E.M.C.

Product complies to:-

EN 50081-1: 1995 EMC Generic emission standard - Residential, commercial and light industry

EN 50081-1: 1995 EMC Generic immunity standard - Residential, commercial and light industry

EN 61010-1/A2: 1995 Safety requirements for electrical equipment for measurement, control and laboratory use.

This product may be affected by electromagnetic interference in an industrial environment.

The Spirax-Monnier ADV can be used with compressed air, oils and water, and some non-corrosive gases.

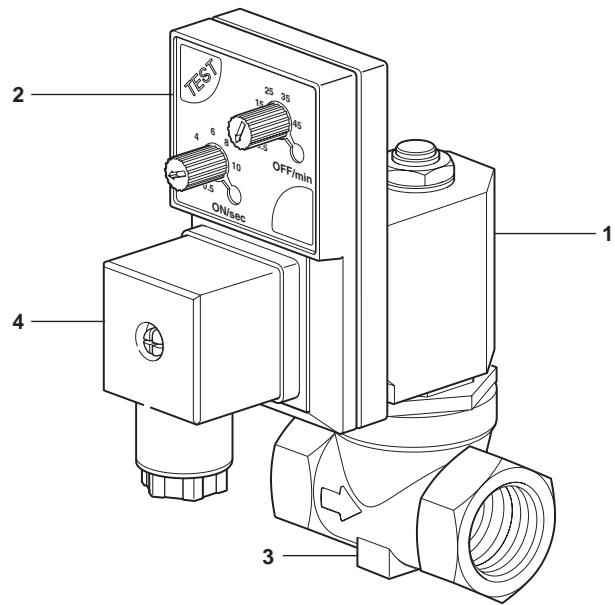

Materials

No.	Part	Material
1	Solenoid body	Nylon
2	Timer body	ABS
3	Valve body	Brass
4	DIN connector	ABS

K_v values

Valve size	¼"	⅜"	½"
K _v value	1.12	1.75	1.72

For conversion: Cv (UK) = Kv x 0.963 Cv (US) = Kv x 1.156

Typical maximum capacity

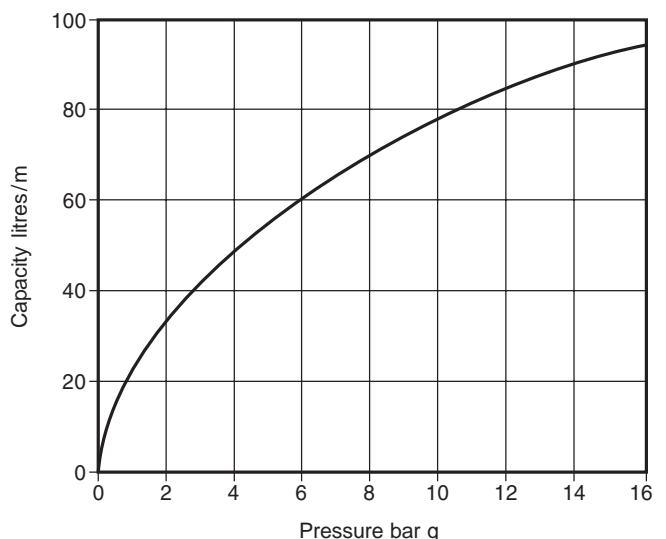

How the ADV works

The Spirax-Monnier ADV trap consists of:

- A poppet valve.
- A direct acting solenoid.
- Twin solid state variable timers, with LED status indication.
- Plug connector.
- Brass valve body.

With the correct power supply connected, and the system pressurized, the timers can be set:

- The 'On' timer (1) controls the discharge period (0.5 to 10 seconds).
- The 'Off' timer (2) determines the frequency of discharge (0.5 to 45 minutes).
- Site conditions (quantity of condensate to be discharged, and amount and type of contamination) will determine the timer setting.
- The LED indicates which timer circuit is live (3 and 4). Operation of the 'test' facility will energise the 'On' timer circuit, opening the discharge valve. The valve will remain open as long as the test button is depressed. This action also resets the 'Off' timer to its start position. The condensate can be discharged to atmosphere (5) or piped away to a suitable container.

Safety information, installation and maintenance

For full details see the Installation and Maintenance Instructions supplied with the product.

Installation note:

On systems with high levels of solid particulate contamination, it is recommended that a strainer (Spirax Sarco Fig 12 Brass) be fitted immediately upstream of the ADV. To simplify routine maintenance and cleaning, a self-venting isolating ball valve should be installed, before the ADV (Spirax-Monnier venting ball valve). All connections should be made with 0.4/1.5 mm² 3 core wire of a rating to suit the supply voltage.

The unit should be installed with the timer and solenoid sections vertical and the main brass valve body horizontal. The valve body can be rotated horizontally through 360° relative to the solenoid, for ease of installation. Note: the direction of flow arrow on the valve body.

Recommended fuse protection 1 amp.

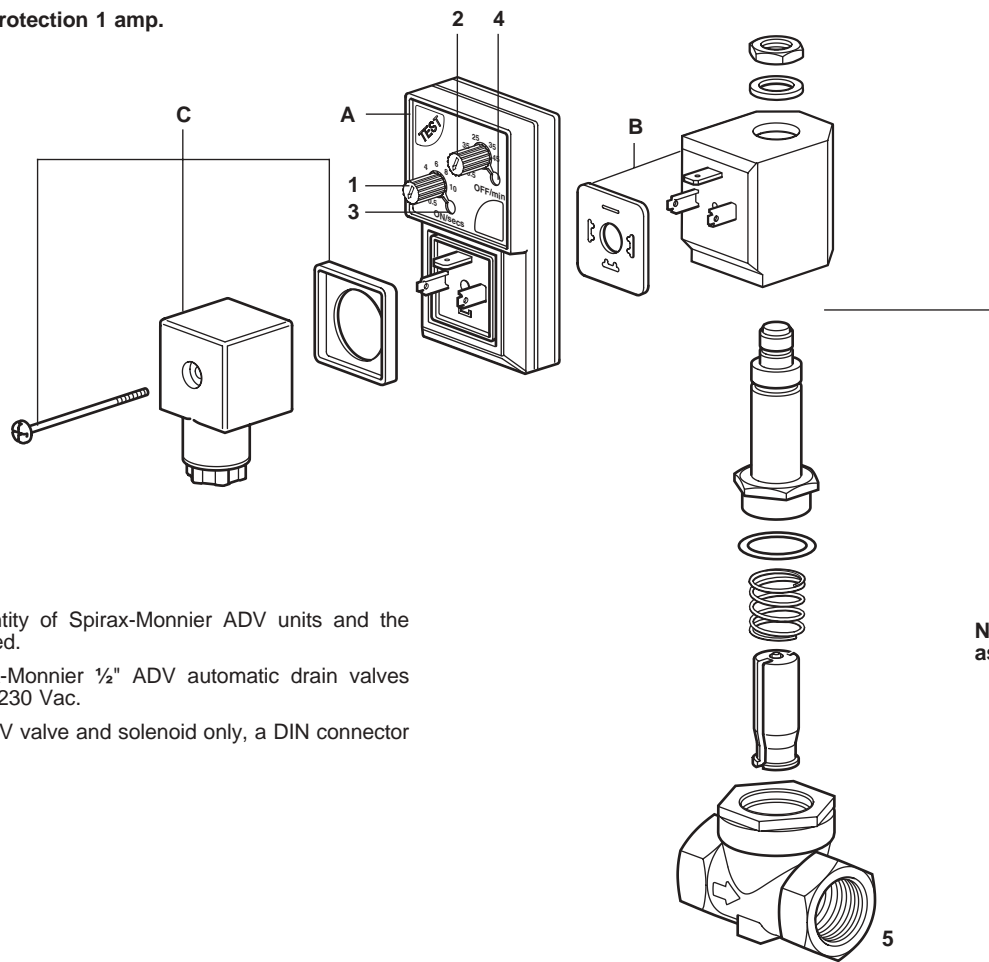

Dimensions/weight (approximate) in mm and kg

A	B	C	D	E	F	G	Weight
90	120	44	20	54	83	15.5	0.55

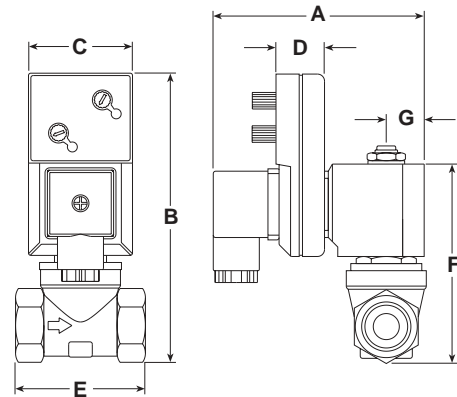

Spare parts

The spare parts available are detailed below. No other parts are supplied as spares.

Available spares

Timer			A
		230 Vac	50 Hz
Solenoid coil and gasket	Specify voltage	110 Vac	50 Hz
		120 Vac	60 Hz
Connector			C

How to order spares

Example: 1 off timer for a Spirax-Monnier ADV automatic drain valve.

How to order

Please state the quantity of Spirax-Monnier ADV units and the solenoid voltage required.

Example: 4 off Spirax-Monnier ½" ADV automatic drain valves having a set voltage of 230 Vac.

Note: If ordering an ADV valve and solenoid only, a DIN connector must also be ordered.