



ABV21i and ABV40i Air Actuated Boiler Blowdown Valves

Description

The Spirax Sarco ABV21i and ABV40i one piece end entry, reduced bore ball valves are fitted with 90° rotary spring return pneumatic actuator, for boiler blowdown duties.

They are used in conjunction with a Spirax Sarco blowdown timer to provide timed control of bottom blowdown, ensuring that the recommended boiler blowdown cycles occur with minimum heat loss, avoiding duplication or omission.

The pneumatic actuator, (which can also be operated with other non-corrosive gases), moves through 90° to open the valve, and has a spring return fail-close operation.

A switch box is mounted on the actuator, and either or both microswitches may be wired to a Building Management System if required.

Note: The BT1050 blowdown timer uses one switch only to indicate 'valve fully closed' or 'valve not fully closed' positions, and does not indicate that the valve has opened fully.

A solenoid valve is required, which may be directly mounted to the NAMUR (VDI/VDE 3845) interface on the actuator.

A suitable solenoid valve may be selected from the Spirax Sarco MV range. Alternatively, an air supply may be connected directly to the actuator port 'A' (1/4" BSP), where it is necessary to install the solenoid valve remote from the actuator.

A standard 1/4" BSP 3-way solenoid valve may also be used.

3-port/2-way NAMUR mounting solenoid types:

MV11 - 230 Vac, **MV12** - 110 Vac, **MV13** - 24 Vac, **MV14** - 24 Vdc

The ABV21i and ABV40i must be installed with the flow in the direction of the arrow on the body.

Principal features:

- Automatic timed blowdown minimises wasted heat.
- Suitable for boiler pressures up to 17.25 bar g.
- Spring return for fail-safe operation.
- Pneumatic actuator for fast response.

Standards

These products comply with the requirements of the European Pressure Equipment Directive 2014/68/EU and carries the  mark when so required.

ISO mounting in accordance with ISO 5211.

Antistatic device complying with ISO 7121 and BS 5351.

Certification

These products are available with certification to EN 10204 3.1.

Note: All certification/inspection requirements must be stated at the time of order placement.

Sizes and pipe connections

DN25, DN32, DN40, DN50 and DN65

Flanged PN40 (F4), PN40 (BS) or ASME B 16.5 Class 300.

Available flange options:

Flange	Face-to-face	Flange thickness
PN40 (F4)	DIN 3002 F4	EN 1092 Part 1
PN40 (BS)	BS 2080	EN 1092 Part 1
ASME 300	ASME B 16.10	ASME B 16.5

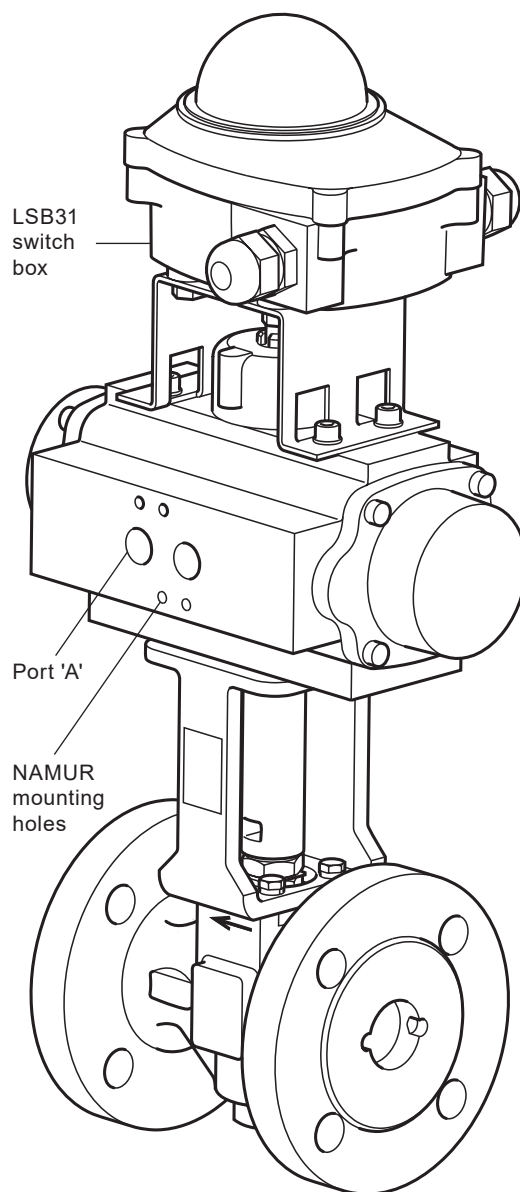

Technical data

Operating time (full stroke)	0.25 - 0.6 seconds		
Operating media	Clean compressed air Non-corrosive gas		
Compressed air consumption @ 6 bar g	DN25	BVA315S/14	0.0002 (N)m ³ /stroke
	DN32	BVA320S/14	0.0006 (N)m ³ /stroke
	DN40 DN50	BVA325S/14 actuator	0.0008 (N)m ³ /stroke
	DN65	BVA330S/14 actuator	0.0011 (N)m ³ /stroke
LSB31 switch rating	10 A 250 Vac		
Protection rating	IP67		
Switch sensor	Mechanical 2 - SPDT		

Pressure / temperature limits

 The product **must not** be used in this region.

ABV21i

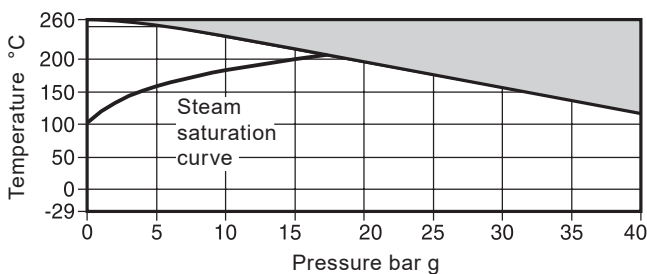

ABV40i

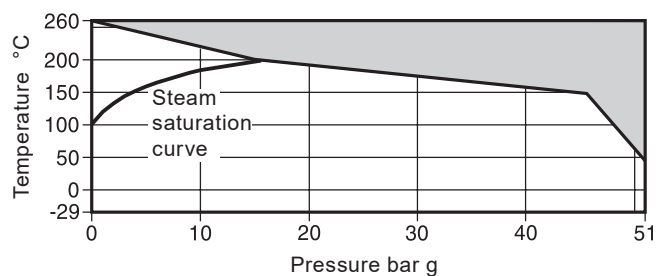

Valve

Body design conditions	ABV21i	PN40
	ABV40i	ASME 300
PMA Maximum allowable pressure	ABV21i	40 bar g @ 120 °C
	ABV40i	51 bar g @ 38 °C
TMA Maximum allowable temperature	260 °C @ 0 bar g	
Minimum allowable temperature	-29 °C	
PMO Maximum operating pressure for saturated steam service	17.25 bar g	
TMO Maximum operating temperature	260 °C @ 0 bar g	
Minimum operating temperature (Note: For lower operating temperatures consult Spirax Sarco)	-29 °C	
ΔPMX Maximum differential pressure is limited to the PMO		
Designed for a maximum cold hydraulic test pressure of:	ABV21i	60 bar g
	ABV40i	76.5 bar g

Actuator

Maximum ambient temperature	80 °C
Minimum ambient temperature	0 °C
Maximum air supply pressure	8 bar g
Minimum air supply pressure	Depends on operating conditions

MV series solenoid

Maximum ambient temperature	50 °C
Minimum ambient temperature	0 °C

Valve coefficients

Size	DN25	DN32	DN40	DN50	DN65
Kv value	30	40	81	103	197

Materials

Valve

Body and insert	Zinc plated carbon steel	ASTM A216 WCB
Stem seals	Antistatic R-PTFE	
Vented ball	Austenitic stainless steel	AISI 316
Stem	DN65	Austenitic stainless steel AISI 316
	DN25 - DN50	Martensitic stainless steel AISI 420
Seats	Carbon and graphite reinforced PTFE	PDR 0.8

Actuator

Body, piston and end caps	Aluminium - anodised
Pinion	Carbon steel - nickel plated
'O' ring seals	Nitrile rubber

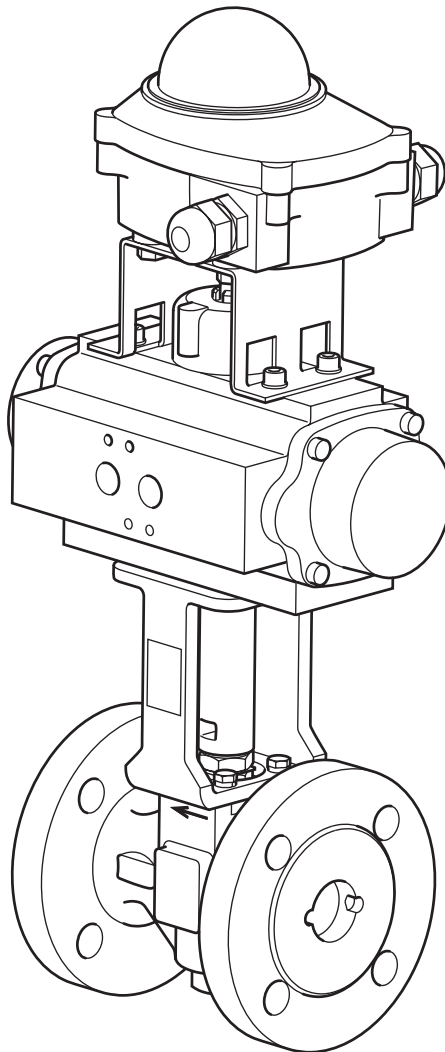

How to specify

Air actuated ball valve, DN40, PN40 with carbon reinforced seats, 90 degree rotary pneumatic actuator and switch box. NAMUR compatible solenoid valve 220 / 240 Vac.

How to order

Example: 1 off Spirax Sarco DN40 ABV21i air actuated boiler blowdown valve having PN40 (F4) flanged connections plus 1 off MV11 solenoid valve 220 / 240 Vac.

Dimensions/weights (approximate) in mm and kg

Valve size	Actuator type	Flange	A	B	C	D	E	F	G	H	Weight
DN25	BVA315S/14	PN40 (F4)	417	125	63	115	196	98	140	56	6.7
		PN40 BS	417	165	103	115	196	98	140	56	6.5
		Class 300	421	165	103	124	196	98	140	56	6.8
DN32	BVA320S/14	PN40 (F4)	456	130	65	140	217	108.5	140	66	9.2
		PN40 BS	456	178	113	140	217	108.5	140	66	9.6
		Class 300	450	178	65	134	217	108.5	140	66	9.4
DN40	BVA325S/14	PN40 (F4)	475	140	70	150	258	129	140	71	11.7
		PN40 BS	475	190	120	150	258	129	140	71	12.2
		Class 300	478	190	120	156	258	129	140	71	13.0
DN50	BVA325S/14	PN40 (F4)	488	150	75	165	258	129	140	71	14.1
		PN40 BS	488	216	141	165	258	129	140	71	15.0
		Class 300	488	216	141	165	258	129	140	71	15.1
DN65	BVA330S/14	PN40 (F4)	530	170	91	185	299	149.5	140	78	20.7
		PN40 BS	530	241	162	185	299	149.5	140	78	22.2
		Class 300	533	241	162	191	299	149.5	140	78	23.3

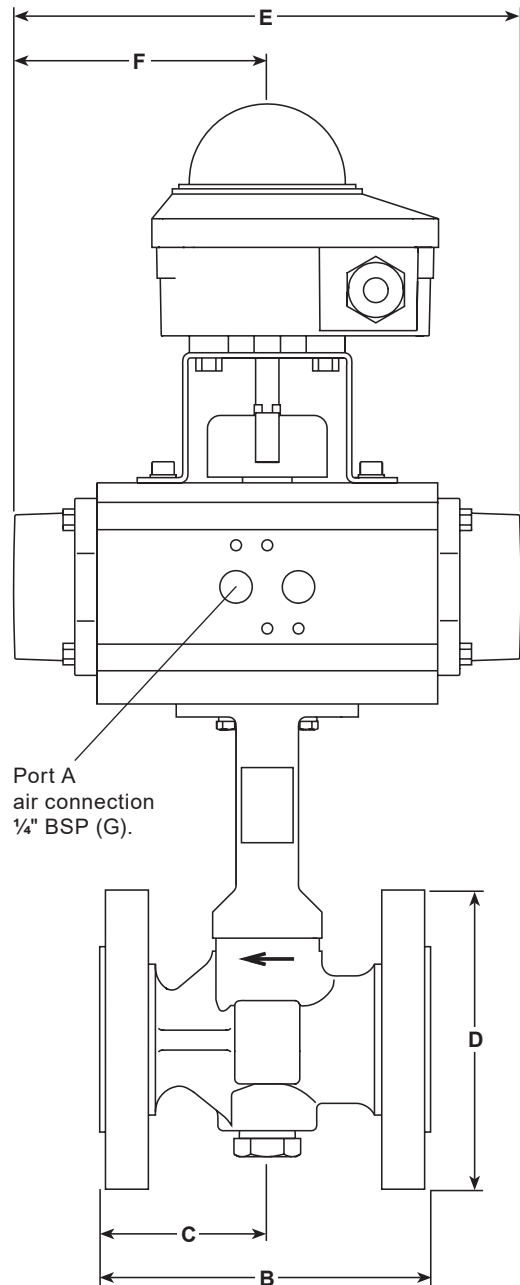
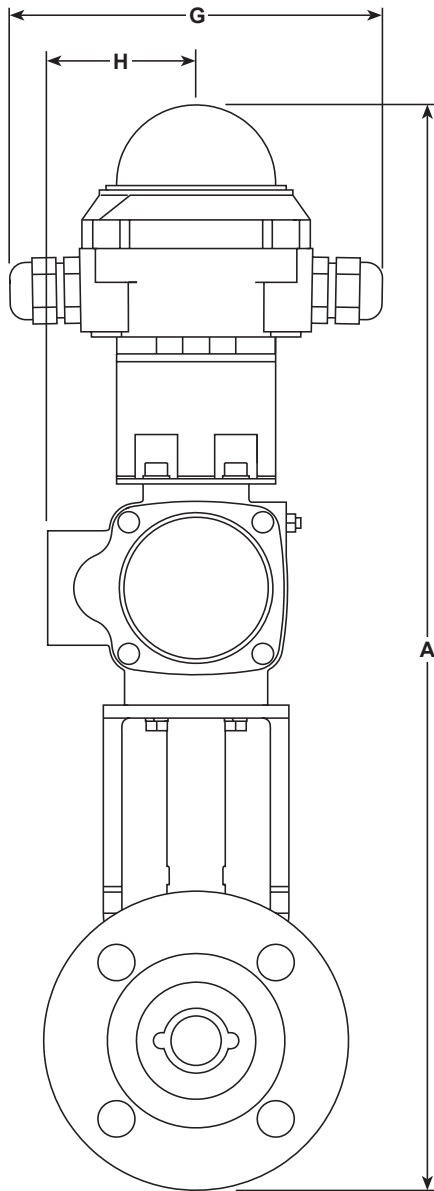

Spare parts

The spare parts available are detailed below. No other parts are available as spares.

Please note: There are no spares available for the switch box.

To ensure correct operation and maintain the warranty, use only Spirax Sarco original parts.

Before actioning any maintenance programme observe the 'Safety Information' in Section 1 of IM-P405-46 supplied with the unit.

Actuator

Spare parts for the BVA300S/14

The available spare parts for the BVA300S/14 are listed on pages 6 and 7.

No other parts are available as spares.

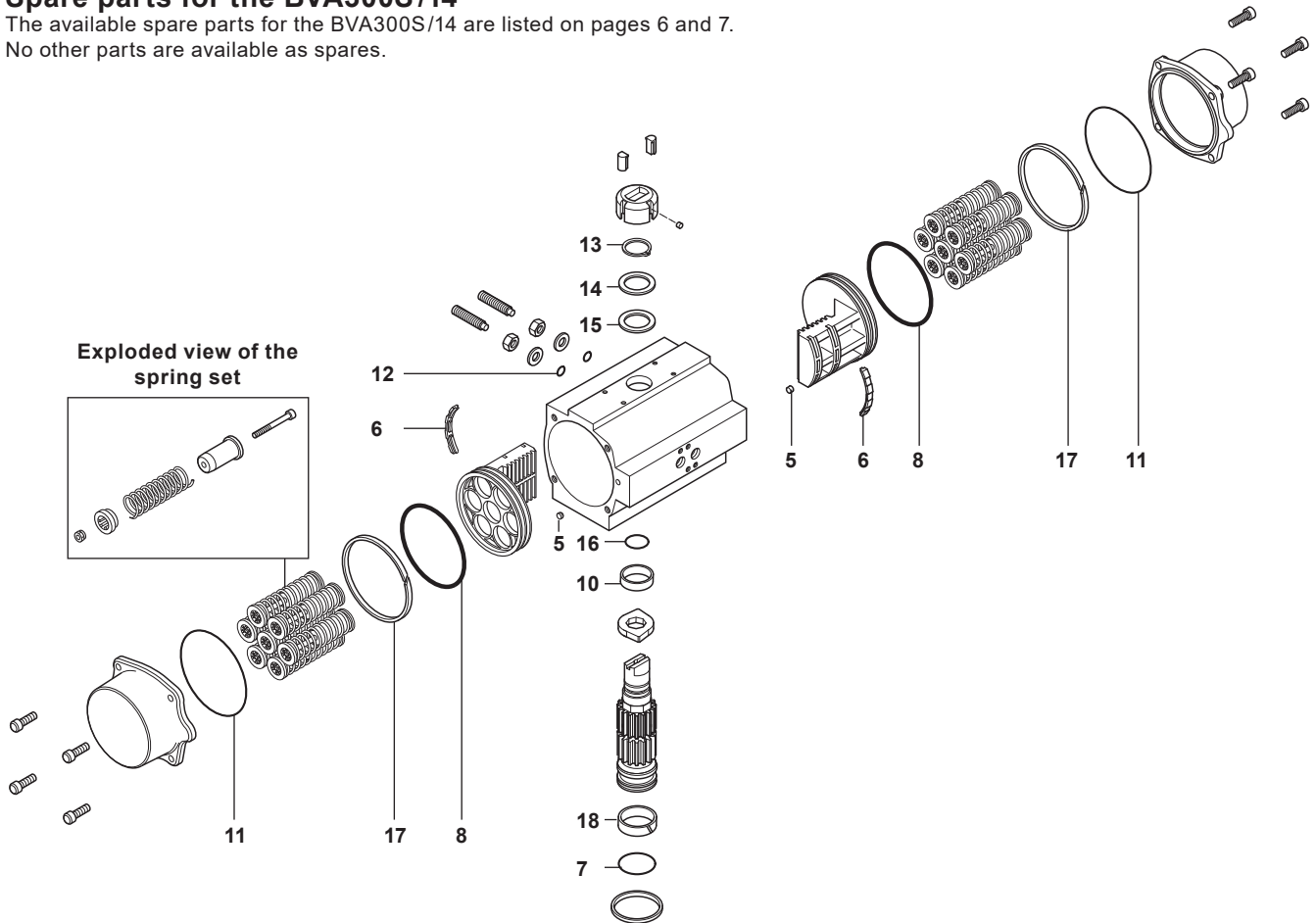

Spare parts

The spare parts available are detailed below. No other parts are supplied as spares.

Available spares

	'O' rings set (NBR)	7, 8, 11, 12, 16
BVA300 series maintenance kit	Pinion washers	13, 14, 15
	Others	5, 6, 10, 17, 18

How to order spares

Always order spares by using the description given in the column headed 'Available spares' and state the nomenclature of the pneumatic actuator that they are intended for.

Note: all the spares mentioned above are sold together in one spare part kit.

Example: 1 - BVA300 series maintenance kit with 'O' rings in NBR for a Spirax Sarco BVA320S/14 pneumatic actuator.

Valve

DN25 to DN50 Spare parts

The spare parts available are shown in solid outline. Parts drawn in a grey line are not supplied as spares.

Available spares

Seats, insert 'O' ring and stem seals	5, 6, 9, 10
Insert tool - Required to aid the removal of the ball valve insert (2)	Not shown

Please note: Spare parts are common for both the ABV21i and ABV40i.

Caution - The ball must be installed with the vent hole on the upstream side of the valve.

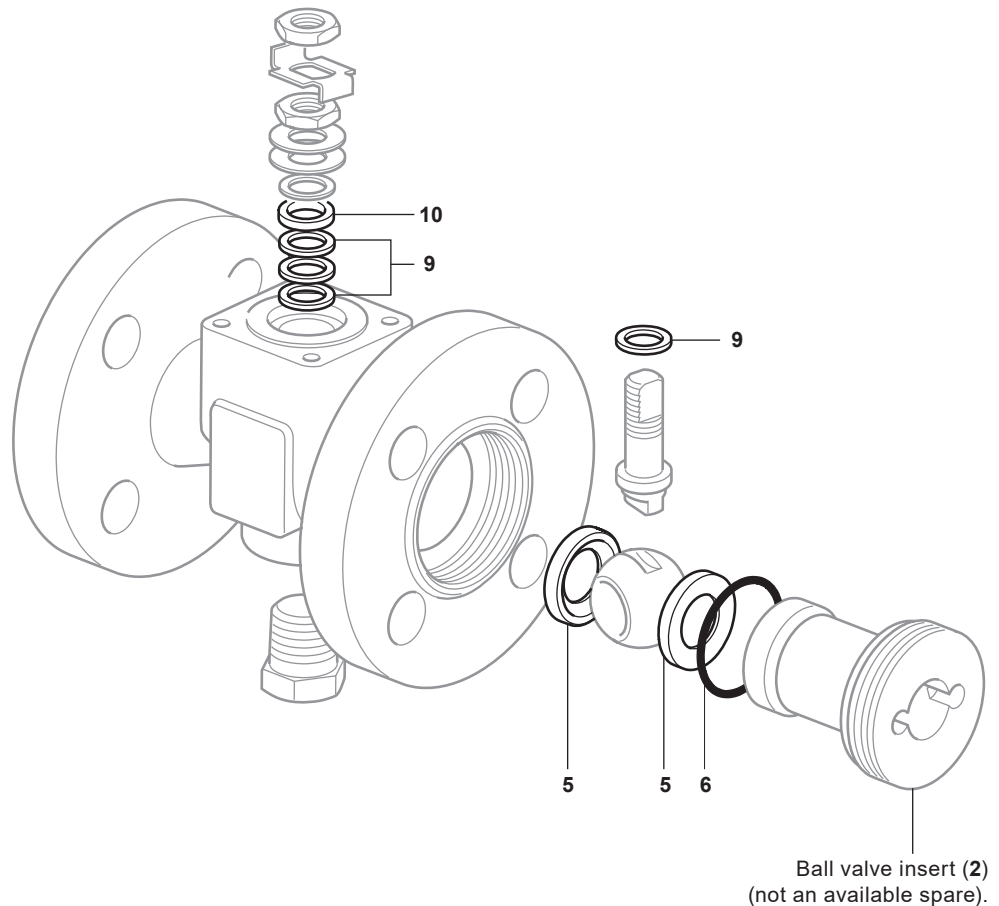

Please note: You will need to order the **Insert tool** listed in the table above to aid removal.

How to order spares

Always order spares by using the description given in the column headed 'Available spares' and state the size and type of ball valve.

Example: 1 set of seats, insert 'O' ring and stem seals for a Spirax Sarco DN50 ABV21i boiler blowdown valve.

DN65 Spare parts

The spare parts available are shown in solid outline. Parts drawn in a grey line are not supplied as spares.

Available spares

Seats, insert 'O' ring, seat 'O' ring, stem 'O' ring, lower stem seals and upper stem packing	5, 6, 7, 8, 11, 12
Insert tool - Required to aid the removal of the ball valve insert (2)	Not shown

Please note: Spare parts are common for both the ABV21i and ABV40i.

Caution - The ball must be installed with the vent hole on the upstream side of the valve.

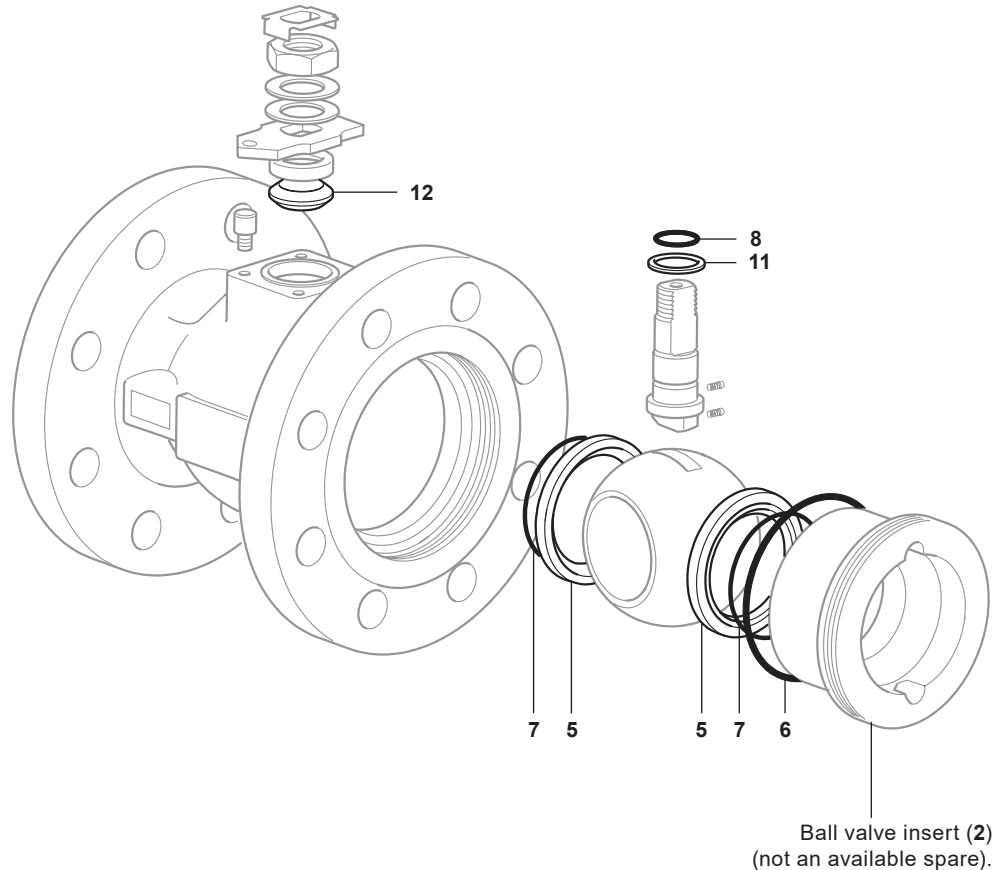

Please note: You will need to order the **Insert tool** listed in the table above to aid removal.

How to order spares

Always order spares by using the description given in the column headed 'Available spares' and state the size and type of ball valve.
Example: 1 set of seats, insert 'O' ring, seat 'O' ring, stem 'O' ring, lower stem seals and upper stem packing for a Spirax Sarco DN50 ABV40i boiler blowdown valve.