

Gilflo ILVA Flowmeters

for steam, liquids and gases



First for Steam Solutions

EXPERTISE | SOLUTIONS | SUSTAINABILITY

spirax
sarco

Gilflo ILVA Flowmeters

Gilflo ILVA Flowmeters will help you implement cost reduction by accurately metering the energy you use. This can lead to improved profitability and a reduction in your carbon footprint.

The Spirax Sarco Gilflo ILVA Flowmeter is perfectly suited for use with most industrial fluids including steam, gases and liquids.

The benefits of flowmetering

Of all the costs your company can control, your energy bill is one of the largest. With the high cost of fuel, it is increasingly important to accurately meter the energy you consume - because the better you understand how and where you use your energy, the easier it is to manage and effectively control.

Spirax Sarco can offer you a range of flowmetering technologies to suit every application so you always have the correct solution for your plant.

The benefit of high turndown

Due to its profiled cone and spring, the Gilflo ILVA is able to measure from full flow down to very low flowrates with a turndown of 100:1. This means that the ILVA continues to measure where other technologies with a lower turndown cannot. With the ILVA, off peak and low demand flow is metered just as accurately as higher flowrates. This gives the benefit that the true flow measurement, and therefore costs are known.

Turndown ratio comparison of flow technologies on saturated steam

Measuring from minimum to maximum flowrates (turndown).

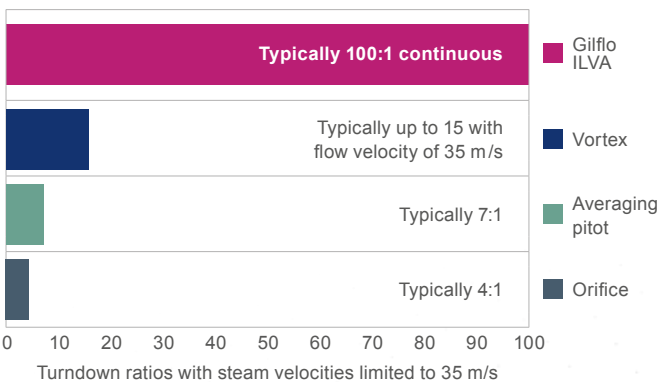

The benefit of compact installation

The Gilflo ILVA profiles the flow, which allows installation when only very short upstream and downstream pipe lengths are available. It achieves this by flattening the profile of the flow stream as it enters and leaves the flowmeter (see diagram below).

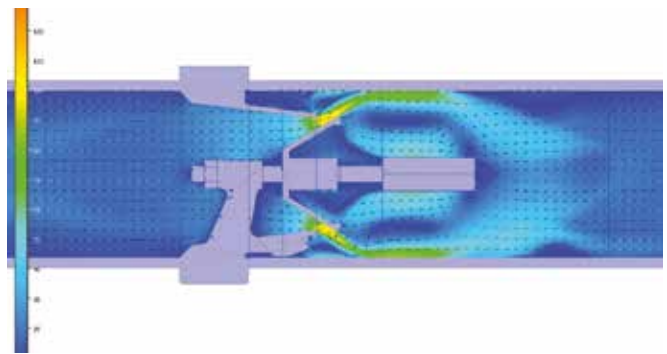

The compact wafer design of the Gilflo ILVA Flowmeter also means that its installed length is much shorter than almost any other technology. It can be installed close to pipe bends, valves or other components that would prevent other types of flowmeter being fitted, as shown in the diagram below.

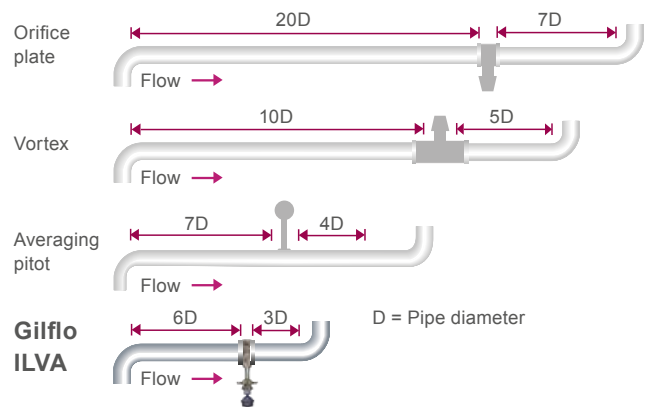

The Gilflo ILVA

Expertly engineered for unrivalled performance

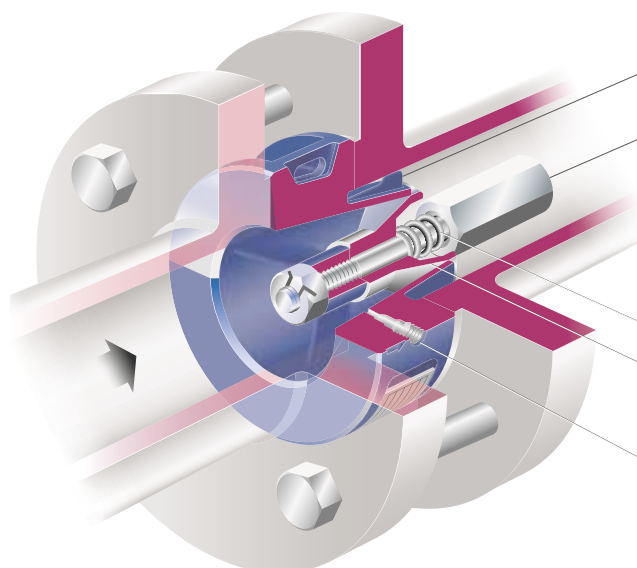

Self-alignment tabs for guaranteed correct installation

Over-range stop prevents damage from surges or excessive flows

Highly stable precision alloy spring operates up to 400°C without loss of performance

Precision cone profiles the flow giving unrivalled 100:1 turndown, for more accurate flow measurement

Wafer design is lighter, quicker and easier to install and is therefore more cost effective

The Gilflo ILVA Flowmeter – at a glance

Range availability:

- Sizes DN50 (2") to DN300 (12")
- All stainless steel 316L body construction
- Pressure rating to match flange specifications
- Temperatures up to 400°C

Applications:

- Cost metering for energy management
- Custody transfer
- Process and control applications
- Boiler load control

Commonly metered fluids:

- Saturated steam
- Superheated steam
- Condensate
- Natural gas
- Nitrogen
- Carbon dioxide
- Compressed air
- Ethylene
- Fuel oil

Some products may not be available in certain markets.

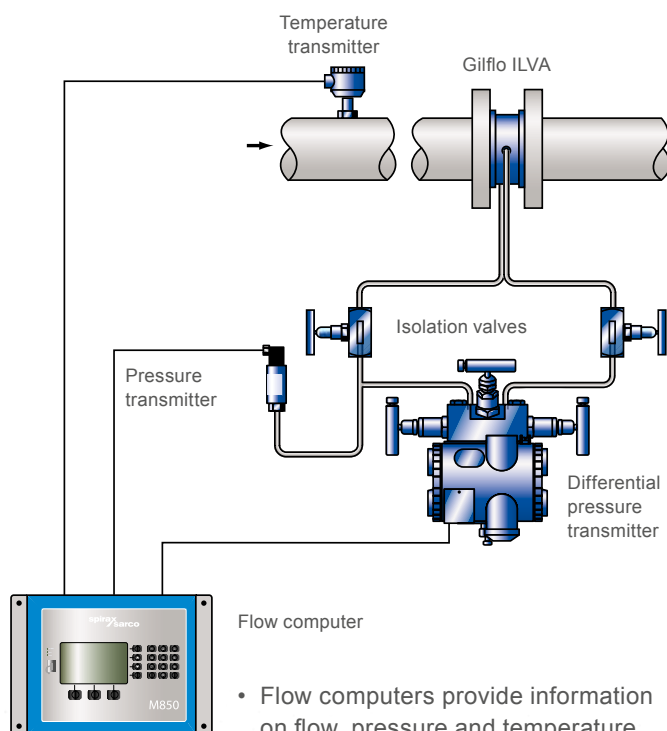

Flow computer

- Flow computers provide information on flow, pressure and temperature.
- Full density compensation.
- Linearisation of Gilflo signal.

Features	Benefits
High accuracy (+/-1% of reading) and unequalled turndown range up to 100:1	Enables metering of low flow rates effectively to help manage costs and accurate measurement providing better awareness of energy usage and efficiency
Very compact installation, requires only six pipe diameter upstream and three downstream	Enables installation where not previously possible with minimal disruption
A compact stem version is now available for DN250 and DN300	Reduced cost and time to install – less downtime
Robust, well proven product technology	Lower total cost of ownership – reduced maintenance and costs, improved reliability

To find out more about our full range of flowmetering products visit spiraxsarco.com



We deliver **global solutions** and **local expertise** through our network of operating companies, manufacturing sites, sales offices and distributors **worldwide.**

Discover how we can help you optimise your system and achieve your goals at spiraxsarco.com.

spirax
sarco

Spirax-Sarco Limited, HQ: Charlton House,
Cheltenham, Gloucestershire, GL53 8ER, UK
T +44 (0)1242 521361
F +44 (0)1242 573342
Contact us: spiraxsarco.com

