

---

**UBP32 Sealed Balanced Pressure Thermostatic  
Steam Trap for use with PC\_ Pipeline Connectors**  
**Installation and Maintenance Instructions**

---

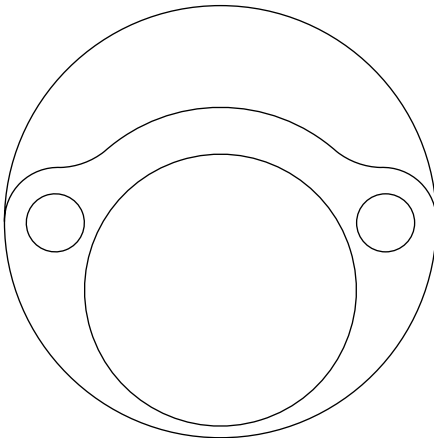

- 1. *General safety information*
- 2. *General product information*
- 3. *Installation*
- 4. *Commissioning*
- 5. *Operation*
- 6. *Maintenance*
- 7. *Spare parts*

# 1. *General safety information*

Safe operation of the unit can only be guaranteed if it is properly installed, commissioned and maintained by a qualified person (see Section 11 of the attached Supplementary Safety Information) in compliance with the operating instructions. General installation and safety instructions for pipeline and plant construction, as well as the proper use of tools and safety equipment must also be complied with.

## **Warning**

The inner and outer gaskets used when installing / maintaining the UBP32 to a PC\_ pipeline connector contain thin stainless steel support rings which may cause physical injury if not handled and disposed of carefully.

## **Isolation**

Consider whether closing isolating valves will put any other part of the system or personnel at risk. Dangers might include; isolation of vents and protective devices or alarms. Ensure isolation valves are turned off in a gradual way to avoid system shocks.

## **Pressure**

Before attempting any maintenance consider what is or may have been in the pipeline. Ensure that any pressure is isolated and safely vented to atmospheric pressure before attempting to maintain the product, this is easily achieved by fitting Spirax Sarco depressurisation valves type DV (see separate literature for details). Do not assume that the system is depressurised even when a pressure gauge indicates zero.

## **Temperature**

Allow time for temperature to normalise after isolation to avoid the danger of burns and consider whether protective clothing (including safety glasses) is required.

## **Disposal**

The product is recyclable. No ecological hazard is anticipated with the disposal of this product providing due care is taken.

# — 2. General product information —

## 2.1 General description

The UBP32 is a maintenance free sealed balanced pressure thermostatic steam trap manufactured in stainless steel. It is designed for steam pressures up to 32 bar g (464 psi g). When installed with a suitable pipeline connector the UBP32 can easily and simply be removed without breaking into the pipeline thus speeding up trap replacement with minimal system downtime. Pipeline connectors are available with screwed, socket weld and flanged connections. The UBP32 is recyclable. It can be supplied with an inbuilt check valve designated UBP32CV.

### Standards

The body to cover welded joint complies with ASME Section IX and BS/EN 288.

### Certification

The UBP32 is available with material certification to EN 10204 3.1.B as standard. All certification must be requested when placing an order.

### Capsule operation

As standard the UBP32 is supplied with a thermostatic capsule (STD) which operates approximately 12°C (21.6°F) below steam saturation temperature. It can also be supplied with capsules operating near-to-steam 4°C (7.2°F) below (NTS) or sub cooled 22°C (39.6°F) below (SUB).

### Note:

For further information see the following Technical Information Sheet, TI-P127-01, which gives full details of: Materials, sizes and pipe connections, dimensions, weights, operating ranges and capacities.

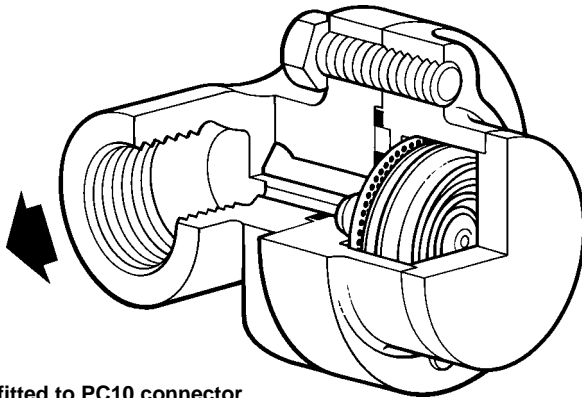

Fig. 1 UBP32 fitted to PC10 connector

## 2.2 Sizes and pipe connections

The UBP32 can be fitted to a variety of different pipeline connectors including:-

<b>PC10</b>	- Straight connector	ANSI/ASME 300	(TI-P128-10)
<b>PC10HP</b>	- Straight connector	ANSI/ASME 600	(TI-P128-10)
<b>PC3_</b>	- Connector with one piston isolation valve	ANSI/ASME 300	(TI-P128-02)
<b>PC4_</b>	- Connector with two piston isolation valves	ANSI/ASME 300	(TI-P128-03)

See the relevant Technical Information Sheet as listed above for details of the connections available on pipeline connectors.

## 2.3 Limiting conditions

Maximum body design conditions	ANSI/ASME 300 (50 bar)	
PMA - Maximum allowable pressure	50 bar g	(725 psi g)
TMA - Maximum allowable temperature	400°C	(752°F)
PMO - Maximum operating pressure	32 bar g	(464 psi g)
TMO - Maximum operating temperature	300°C	(572°F)
Designed for a maximum cold hydraulic test pressure of:	75 bar g	(1087.5 psi g)

**Note:** The model of pipeline connector and connections selected will dictate the maximum operating pressure and temperature of the complete assembly. Consult the relevant Technical Information Sheet, as listed in Section 2.2, for this information.

## 2.4 Operating range

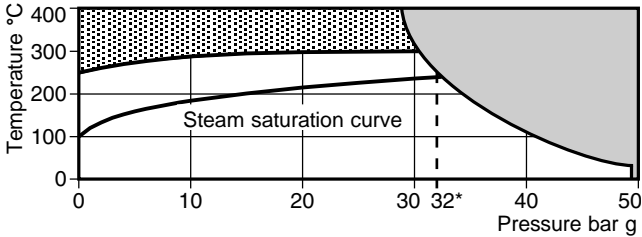

 The product must not be used in this region.

 The product should not be used in this region as damage to internals may occur.

\*PMO Maximum operating pressure recommended for saturated steam is 32 bar g (464 psi g).

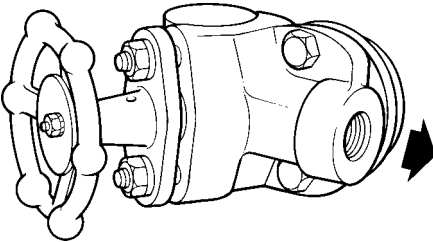

Fig. 2 UBP32 fitted to PC3\_connector

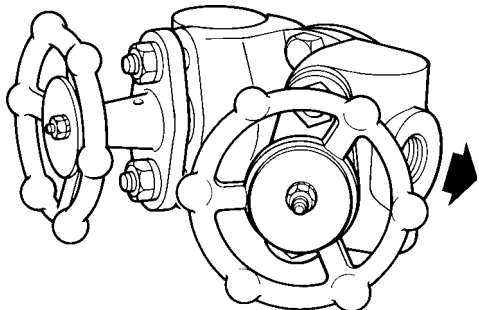

Fig. 3 UBP32 fitted to PC4\_connector

---

## 3. Installation

---

**Note:** Before actioning any installation observe the 'Safety information' in Section 1.

Referring to the Installation and Maintenance Instructions, name-plate and Technical Information Sheet, check that the product is suitable for the intended installation:

- 3.1** Check materials, pressure and temperature and their maximum values. If the maximum operating limit of the product is lower than that of the system in which it is being fitted, ensure that a safety device is included in the system to prevent overpressurisation.
- 3.2** Determine the correct installation situation and the direction of fluid flow.
- 3.3** Remove protective covers from all connections.
- 3.4** The UBP32 can be installed on any pipeline connector in any plane. See separate Installation and Maintenance Instructions for Spirax Sarco pipeline connectors (IM-P128-06, IM-P128-11 and IM-P128-13). Ensure that both gaskets are clean and undamaged and that the transfer holes are clear. Place the UBP32 body against the connector gasket face and apply a small amount anti-seize compound to the threads of the connector screws (**10**). Tighten screws finger tight and ensure that the trap body is parallel to the connector. Tighten the screws to the recommended torque (see Table 1, page 7). Open isolation valves slowly until normal operating conditions are achieved.
- 3.5** Check for leaks.

**Note:** If the trap is to discharge to atmosphere ensure it is a safe place, the discharging fluid may be at a temperature of 100°C (212°F).

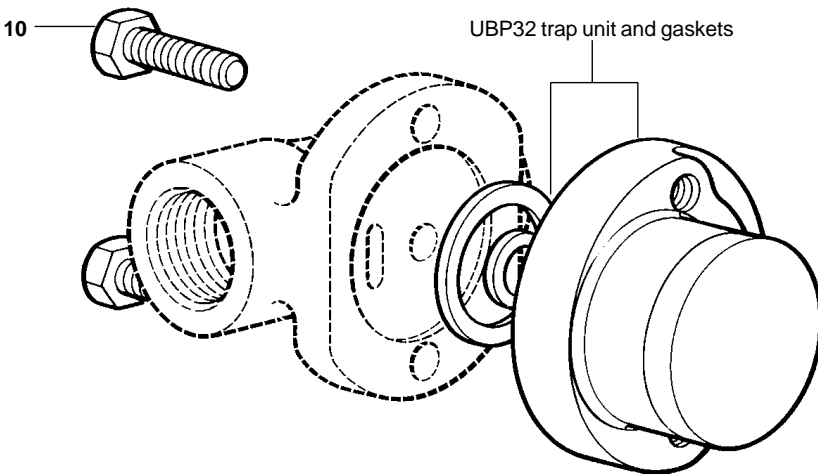

Fig. 4

---

## 4. Commissioning

---

After installation or maintenance ensure that the system is fully functioning. Carry out tests on any alarms or protective devices.

---

## 5. Operation

---

The operating element is a capsule containing a small quantity of a special liquid with a boiling point below that of water. In the cold conditions that exist at start-up, the capsule is relaxed. The valve is off its seat and is wide open, allowing unrestricted removal of air. This is a feature of all balanced pressure traps and explains why they are well suited to air venting.

As condensate passes through the balanced pressure steam trap, heat is transferred to the liquid in the capsule. The fill liquid boils before steam reaches the trap. The vapour pressure within the capsule causes it to expand and the trap shuts. Heat loss from the trap then cools the water surrounding the capsule, the fill condenses and the capsule contracts, opening the valve and releasing condensate until steam temperature approaches again at which the cycle is repeated.

---

## 6. Maintenance

---

**Note:** Before actioning any maintenance program observe the 'Safety information' in Section 1.

### Warning

**The inner and outer gaskets used when installing / maintaining the UBP32 to a PC\_ pipeline connector contain thin stainless steel support rings which may cause physical injury if not handled and disposed of carefully.**

### 6.1 General information

Before undertaking any maintenance on the trap it must be isolated from both the supply line and return line and any pressure allowed to safely normalise to atmosphere. The trap should then be allowed to cool. When reassembling, ensure that all joint faces are clean.

### 6.2 Replacement of the trap unit:

- Ensure that the correct tools and necessary protective equipment are used at all times.
- Replacement of the trap unit is achieved by removing the two connector screws (10) and removing the trap.
- The new trap unit should be positioned against the connector gasket face and apply a small amount of anti-seize compound to the threads of the connector screws.
- Tighten screws finger tight and ensure that the trap body is parallel to the connector.
- Tighten the screws to the recommended torque (see Table 1).
- Open isolation valves slowly until normal operating conditions are achieved.
- Check for leaks.

## 7. Spare parts

The UB32 is a sealed non-maintainable trap unit. No internal spares are available. The spares which are available are shown in heavy outline. Parts shown in a broken line are not supplied as spares.

### Available spares

Connector screws	<b>10</b>
Complete UB32 trap unit inclusive of gaskets and connector screws (10)	

### How to order spares

Always order spare parts by using the description given in the column headed 'Available spares' and state the size, Model No. and pressure rating of the trap.

**Example:** 2 - Connector screws for a UB32 sealed balanced pressure thermostatic steam trap.

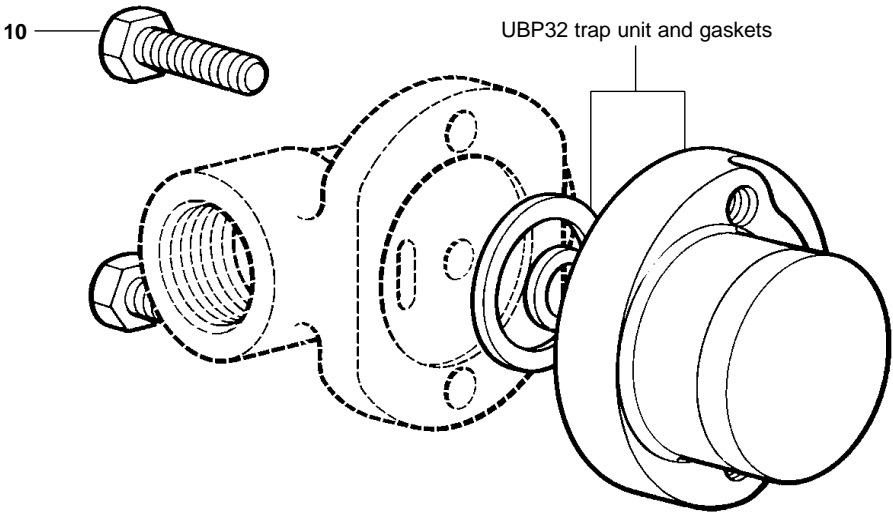



Fig. 5

**Table 1 Recommended tightening torques**

Item		or		N m	(lbf ft)
		mm			
<b>10</b>	3/16" A/F			30 - 35	(22 - 26)

