

---

---

# UBP32 Sealed Balanced Pressure Thermostatic Steam Trap for use with PC\_ Pipeline Connectors

## Installation and Maintenance Instructions

---

---

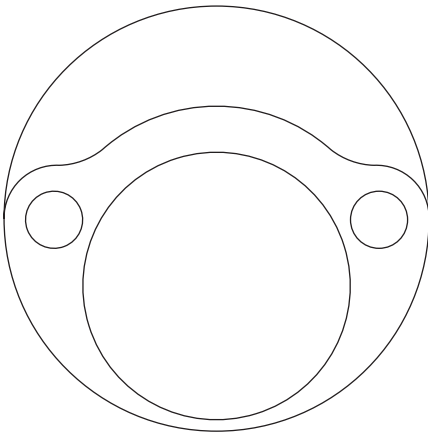

1. Safety information
2. General product information
3. Installation
4. Commissioning
5. Operation
6. Maintenance
7. Spare parts

# 1. Safety information

Safe operation of these products can only be guaranteed if they are properly installed, commissioned, used and maintained by qualified personnel (see Section 1.11 on this document) in compliance with the operating instructions. General installation and safety instructions for pipeline and plant construction, as well as the proper use of tools and safety equipment must also be complied with.

## 1.1 Intended use

Referring to the Installation and Maintenance Instructions, name-plate and Technical Information Sheet, check that the product is suitable for the intended use/application.

The products listed below comply with the requirements of the Pressure Equipment Directive (PED) and carry the  mark when so required.

The products fall within the following Pressure Equipment Directive categories:

Product	Group 2 Gases	Group 2 Liquids
UBP21 and UBP32	SEP	SEP

- i) The products have been specifically designed for use on steam, air or water/condensate which are in Group 2 of the above mentioned Pressure Equipment Directive. The products' use on other fluids may be possible but, if this is contemplated, Spirax Sarco should be contacted to confirm the suitability of the product for the application being considered.
- ii) Check material suitability, pressure and temperature and their maximum and minimum values. If the maximum operating limits of the product are lower than those of the system in which it is being fitted, or if malfunction of the product could result in a dangerous overpressure or overtemperature occurrence, ensure a safety device is included in the system to prevent such over-limit situations.
- iii) Determine the correct installation situation and direction of fluid flow.
- iv) Spirax Sarco products are not intended to withstand external stresses that may be induced by any system to which they are fitted. It is the responsibility of the installer to consider these stresses and take adequate precautions to minimise them.
- v) Remove protection covers from all connections before installation.

## 1.2 Access

Ensure safe access and if necessary a safe working platform (suitably guarded) before attempting to work on the product. Arrange suitable lifting gear if required.

## 1.3 Lighting

Ensure adequate lighting, particularly where detailed or intricate work is required.

## 1.4 Hazardous liquids or gases in the pipeline

Consider what is in the pipeline or what may have been in the pipeline at some previous time. Consider: flammable materials, substances hazardous to health, extremes of temperature.

## 1.5 Hazardous environment around the product

Consider: explosion risk areas, lack of oxygen (e.g. tanks, pits), dangerous gases, extremes of temperature, hot surfaces, fire hazard (e.g. during welding), excessive noise, moving machinery.

## 1.6 The system

Consider the effect on the complete system of the work proposed. Will any proposed action (e.g. closing isolation valves, electrical isolation) put any other part of the system or any personnel at risk? Dangers might include isolation of vents or protective devices or the rendering ineffective of controls or alarms. Ensure isolation valves are turned on and off in a gradual way to avoid system shocks.

## 1.7 Pressure systems

Ensure that any pressure is isolated and safely vented to atmospheric pressure. Consider double isolation (double block and bleed) and the locking or labelling of closed valves. Do not assume that the system has depressurised even when the pressure gauge indicates zero.

## 1.8 Temperature

Allow time for temperature to normalise after isolation to avoid danger of burns. If parts made from Viton have been subjected to a temperature approaching 315 °C (599 °F) or higher, it may have decomposed and formed hydrofluoric acid. Avoid skin contact and inhalation of any fumes as the acid will cause deep skin burns and damage the respiratory system. If parts made from PTFE have been subjected to a temperature approaching 260 °C (500 °F) or higher, they will give off toxic fumes, which if inhaled are likely to cause temporary discomfort. It is essential for a no smoking rule to be enforced in all areas where PTFE is stored, handled, or processed as persons inhaling the fumes from burning tobacco contaminated with PTFE particles can develop 'polymer fume fever'.

## 1.9 Tools and consumables

Before starting work ensure that you have suitable tools and/or consumables available. Use only genuine Spirax Sarco replacement parts.

## 1.10 Protective clothing

Consider whether you and/or others in the vicinity require any protective clothing to protect against the hazards of, for example, chemicals, high/ low temperature, radiation, noise, falling objects, and dangers to eyes and face.

## 1.11 Permits to work

All work must be carried out or be supervised by a suitably competent person. Installation and operating personnel should be trained in the correct use of the product according to the Installation and Maintenance Instructions.

Where a formal 'permit to work' system is in force it must be complied with. Where there is no such system, it is recommended that a responsible person should know what work is going on and, where necessary, arrange to have an assistant whose primary responsibility is safety.

Post 'warning notices' if necessary.

## 1.12 Handling

Manual handling of large and/or heavy products may present a risk of injury. Lifting, pushing, pulling, carrying or supporting a load by bodily force can cause injury particularly to the back. You are advised to assess the risks taking into account the task, the individual, the load and the working environment and use the appropriate handling method depending on the circumstances of the work being done.

## 1.13 Residual hazards

In normal use the external surface of the product may be very hot. If used at the maximum permitted operating conditions the surface temperature of some products may reach temperatures in excess of 300 °C (572 °F). Many products are not self-draining. Take due care when dismantling or removing the product from an installation (refer to 'Maintenance instructions'). Freezing Provision must be made to protect products which are not self-draining against frost damage in environments where they may be exposed to temperatures below freezing point.

## 1.14 Safety information - Product specific

See the relevant Sections of the attached Installation and Maintenance Instructions for specific details relating to these products.

## 1.15 Disposal

Unless otherwise stated in the Installation and Maintenance Instructions, this product is recyclable and no ecological hazard is anticipated with its disposal providing due care is taken, except:

### Viton:

- Can be landfilled, when in compliance with National and Local regulations.
- Can be incinerated, but a scrubber must be used to remove Hydrogen Flouride, which is evolved from the product and with compliance to National and Local regulations.
- Is insoluble in aquatic media.

### PTFE:

- Can only be disposed of by approved methods, not incineration.
- Keep PTFE waste in a separate container do not mix it with other rubbish, and consign it to a landfill site.

## 1.16 Returning products

Customers and stockists are reminded that under EC Health, Safety and Environment Law, when returning products to Spirax Sarco they must provide information on any hazards and the precautions to be taken due to contamination residues or mechanical damage which may present a health, safety or environmental risk. This information must be provided in writing including Health and Safety data sheets relating to any substances identified as hazardous or potentially hazardous.

## 2. General product information

### 2.1 General description

The UBP32 is a maintenance free sealed balanced pressure thermostatic steam trap manufactured in stainless steel. It is designed for steam pressures up to 32 bar g (464 psi g). When installed with a suitable pipeline connector the UBP32 can easily and simply be removed without breaking into the pipeline thus speeding up trap replacement with minimal system downtime. Pipeline connectors are available with screwed, socket weld and flanged connections. The UBP32 is recyclable. It can be supplied with an inbuilt check valve designated UBP32CV.

The body and cover meet typical industry standards including Charpy impact testing of 27J @ -30 °C.

### Standards

The body to cover welded joint complies with ASME Section IX and BS/EN 288.

### Certification

The UBP32 is available with material certification to EN 10204 3.1.B as standard. All certification must be requested when placing an order.

### Capsule operation

As standard the UBP32 is supplied with a thermostatic capsule (STD) which operates approximately 12 °C (21.6 °F) below steam saturation temperature. It can also be supplied with capsules operating near-to-steam 4 °C (7.2 °F) below (NTS) or sub cooled 22 °C (39.6 °F) below (SUB).

### Note:

For further information see the following Technical Information Sheet, TI-P127-01, which gives full details of: Materials, sizes and pipe connections, dimensions, weights, operating ranges and capacities.

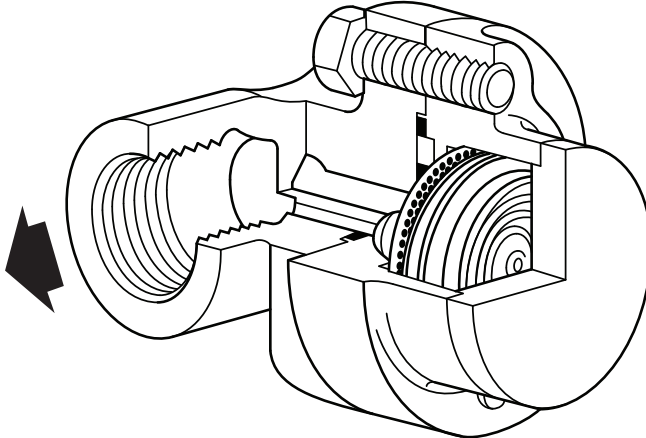

Fig. 1 UBP32 fitted to PC10 connector

## 2.2 Sizes and pipe connections

The UBP32 can be fitted to a variety of different pipeline connectors including:-

<b>PC10</b>	- Straight connector	ANSI/ASME 300	(TI-P128-10)
<b>PC10HP</b>	- Straight connector	ANSI/ASME 600	(TI-P128-10)
<b>PC3_</b>	- Connector with one piston isolation valve	ANSI/ASME 300	(TI-P128-02)
<b>PC4_</b>	- Connector with two piston isolation valves	ANSI/ASME 300	(TI-P128-03)

See the relevant Technical Information Sheet as listed above for details of the connections available on pipeline connectors.

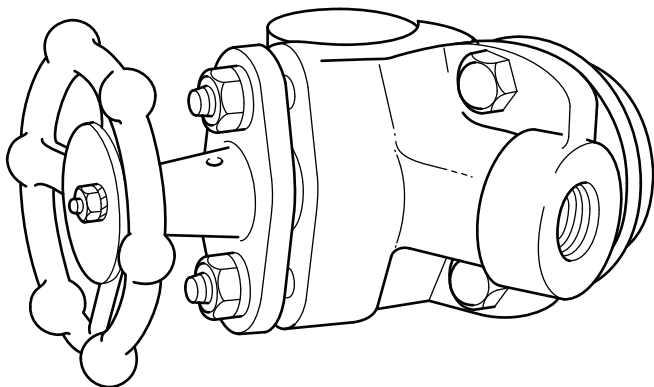

Fig. 2 UBP32 fitted to PC3\_ connector

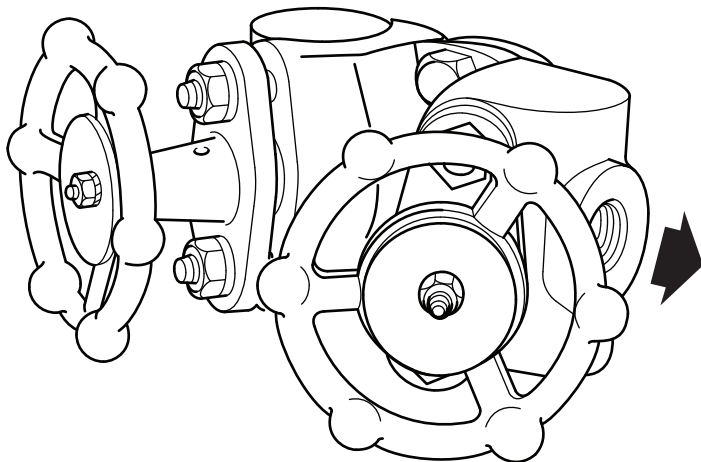
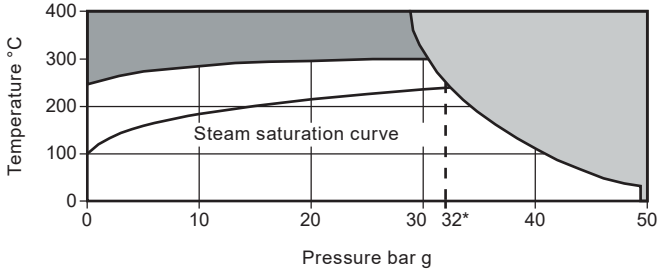



Fig. 3 UBP32 fitted to PC4\_ connector

## 2.4 Pressure/temperature limits



 The product **must not** be used in this region.

 The product should not be used in this region or beyond its operating range as damage to the internals may occur.

\*PMO Maximum operating pressure recommended for saturated steam is 32 bar g (464 psi g).

Maximum body design conditions	ANSI/ASME 300	(50 bar)
PMA Maximum allowable pressure	50 bar g	(725 psi g)
TMA Maximum allowable temperature	400 °C	(752 °F)
Minimum Allowable Temperature		-48 °C
PMO Maximum operating pressure	32 bar g	(464 psi g)
TMO Maximum operating temperature	300 °C	(572 °F)
Minimum Operating Temperature		0 °C (non freezing)
Designed for a maximum cold hydraulic test pressure of:	75 bar g	(1 087.5 psi g)

**Note:** The model of pipeline connector and connections selected will dictate the maximum operating pressure and temperature of the complete assembly. Consult the relevant Technical Information Sheet, as listed in Section 2.2, for this information.

# 3. Installation

**Note:** Before actioning any installation observe the 'Safety information' in Section 1.

Referring to the Installation and Maintenance Instructions, name-plate and Technical Information Sheet, check that the product is suitable for the intended installation:

- 3.1** Check materials, pressure and temperature and their maximum values. If the maximum operating limit of the product is lower than that of the system in which it is being fitted, ensure that a safety device is included in the system to prevent overpressurisation.
- 3.2** Determine the correct installation situation and the direction of fluid flow.
- 3.3** Remove protective covers from all connections.
- 3.4** The UBP32 can be installed on any pipeline connector in any plane. See separate Installation and Maintenance Instructions for Spirax Sarco pipeline connectors (IM-P128-06, IM-P128-11 and IM-P128-13). Ensure that both gaskets are clean and undamaged and that the transfer holes are clear. Place the UBP32 body against the connector gasket face and apply a small amount anti-seize compound to the threads of the connector screws (10). Tighten screws finger tight and ensure that the trap body is parallel to the connector. Tighten the screws to the recommended torque (see Table 1, page 12). Open isolation valves slowly until normal operating conditions are achieved.
- 3.5** Check for leaks.

**Note:** If the trap is to discharge to atmosphere ensure it is a safe place, the discharging fluid may be at a temperature of 100 °C (212 °F).

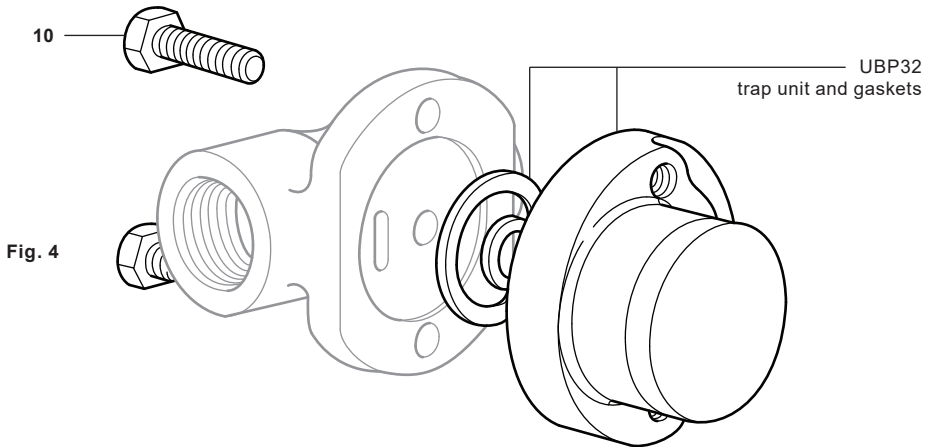



## 4. Commissioning

After installation or maintenance ensure that the system is fully functioning. Carry out tests on any alarms or protective devices.

## 5. Operation

The operating element is a capsule containing a small quantity of a special liquid with a boiling point below that of water. In the cold conditions that exist at start-up, the capsule is relaxed. The valve is off its seat and is wide open, allowing unrestricted removal of air. This is a feature of all balanced pressure traps and explains why they are well suited to air venting. As condensate passes through the balanced pressure steam trap, heat is transferred to the liquid in the capsule. The fill liquid boils before steam reaches the trap. The vapour pressure within the capsule causes it to expand and the trap shuts. Heat loss from the trap then cools the water surrounding the capsule, the fill condenses and the capsule contracts, opening the valve and releasing condensate until steam temperature approaches again at which the cycle is repeated.

## 6. Maintenance

**Note:** Before actioning any maintenance programme observe the 'Safety information' in Section 1.

### Warning

The inner and outer gaskets used when installing/maintaining the UBP32 to a PC\_ pipeline connector contain thin stainless steel support rings which may cause physical injury if not handled and disposed of carefully.

### 6.1 General information

Before undertaking any maintenance on the trap it must be isolated from both the supply line and return line and any pressure allowed to safely normalise to atmosphere. The trap should then be allowed to cool. When reassembling, ensure that all joint faces are clean.

### 6.2 Replacement of the trap unit:

- Ensure that the correct tools and necessary protective equipment are used at all times.
- Replacement of the trap unit is achieved by removing the two connector screws (10) and removing the trap.
- The new trap unit should be positioned against the connector gasket face and apply a small amount of anti-seize compound to the threads of the connector screws.
- Tighten screws finger tight and ensure that the trap body is parallel to the connector.
- Tighten the screws to the recommended torque (see Table 1).
- Open isolation valves slowly until normal operating conditions are achieved.
- Check for leaks.

# 7. Spare parts

The UBP32 is a sealed non-maintainable trap unit. No internal spares are available. The spares which are available are shown in heavy outline. Parts shown in a grey line are not supplied as spares.

## Available spares

Connector screws	<b>10</b>
Complete UBP32 trap unit inclusive of gaskets and connector screws (10)	



## How to order spares

Always order spare parts by using the description given in the column headed 'Available spares' and state the size, Model No. and pressure rating of the trap.

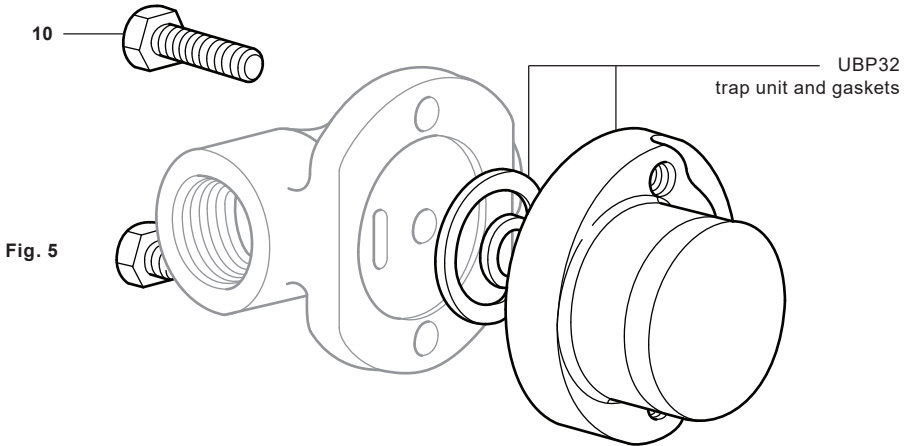
**Example:** 2 - Connector screws for a UBP32 sealed balanced pressure thermostatic steam trap.



**Table 1 Recommended tightening torques**

Item	 or mm		N m	(lbf ft)
10	9 A/F		30 - 35	(22 - 26)



