

Type 130 and HL10

'Safeguard High Limit Control'

Installation and Maintenance Instructions

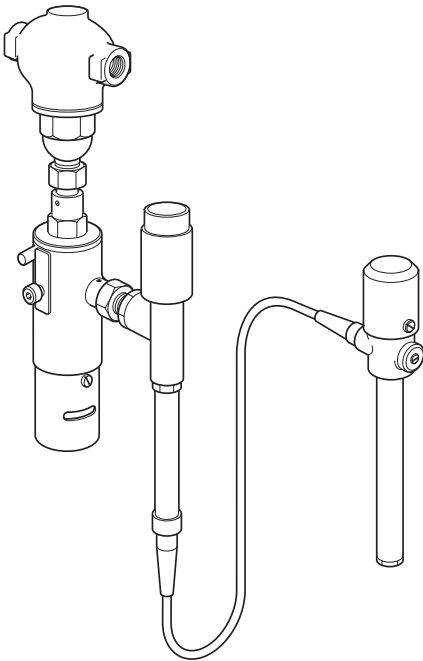

1. Safety information
2. General product information
3. Installation
4. Setting and adjustment
5. Operation
6. Maintenance
7. Spare parts

1. Safety information

Safe operation of these products can only be guaranteed if they are properly installed, commissioned, used and maintained by qualified personnel (see Section 1.11 on this document) in compliance with the operating instructions. General installation and safety instructions for pipeline and plant construction, as well as the proper use of tools and safety equipment must also be complied with.

1.1 Intended use

Referring to the Installation and Maintenance Instructions, name-plate and Technical Information Sheet, check that the product is suitable for the intended use / application. The products comply with the requirements of the European Pressure Equipment Directive 2014/68/EU and fall within category 'SEP'.

It should be noted that products within this category are required by the directive not to carry the  mark.

- i) The products have been specifically designed for use on steam and water, which are in Group 2 of the above mentioned Pressure Equipment Directive. The products' use on other fluids may be possible but, if this is contemplated, Spirax Sarco should be contacted to confirm the suitability of the product for the application being considered.
- ii) Check material suitability, pressure and temperature and their maximum and minimum values. If the maximum operating limits of the product are lower than those of the system in which it is being fitted, or if malfunction of the product could result in a dangerous overpressure or overtemperature occurrence, ensure a safety device is included in the system to prevent such over-limit situations.
- iii) Determine the correct installation situation and direction of fluid flow.
- iv) Spirax Sarco products are not intended to withstand external stresses that may be induced by any system to which they are fitted. It is the responsibility of the installer to consider these stresses and take adequate precautions to minimise them.
- v) Remove protection covers from all connections before installation.

1.2 Access

Ensure safe access and if necessary a safe working platform (suitably guarded) before attempting to work on the product. Arrange suitable lifting gear if required.

1.3 Lighting

Ensure adequate lighting, particularly where detailed or intricate work is required.

1.4 Hazardous liquids or gases in the pipeline

Consider what is in the pipeline or what may have been in the pipeline at some previous time. Consider: flammable materials, substances hazardous to health, extremes of temperature.

1.5 Hazardous environment around the product

Consider: explosion risk areas, lack of oxygen (e.g. tanks, pits), dangerous gases, extremes of temperature, hot surfaces, fire hazard (e.g. during welding), excessive noise, moving machinery.

1.6 The system

Consider the effect on the complete system of the work proposed. Will any proposed action (e.g. closing isolation valves, electrical isolation) put any other part of the system or any personnel at risk?

Dangers might include isolation of vents or protective devices or the rendering ineffective of controls or alarms. Ensure isolation valves are turned on and off in a gradual way to avoid system shocks.

1.7 Pressure systems

Ensure that any pressure is isolated and safely vented to atmospheric pressure. Consider double isolation (double block and bleed) and the locking or labelling of closed valves. Do not assume that the system has depressurised even when the pressure gauge indicates zero.

1.8 Temperature

Allow time for temperature to normalise after isolation to avoid danger of burns.

1.9 Tools and consumables

Before starting work ensure that you have suitable tools and /or consumables available. Use only genuine Spirax Sarco replacement parts.

1.10 Protective clothing

Consider whether you and / or others in the vicinity require any protective clothing to protect against the hazards of, for example, chemicals, high / low temperature, radiation, noise, falling objects, and dangers to eyes and face.

1.11 Permits to work

All work must be carried out or be supervised by a suitably competent person. Installation and operating personnel should be trained in the correct use of the product according to the Installation and Maintenance Instructions.

Where a formal 'permit to work' system is in force it must be complied with. Where there is no such system, it is recommended that a responsible person should know what work is going on and, where necessary, arrange to have an assistant whose primary responsibility is safety.

Post 'warning notices' if necessary.

1.12 Handling

Manual handling of large and / or heavy products may present a risk of injury. Lifting, pushing, pulling, carrying or supporting a load by bodily force can cause injury particularly to the back. You are advised to assess the risks taking into account the task, the individual, the load and the working environment and use the appropriate handling method depending on the circumstances of the work being done.

1.13 Residual hazards

In normal use the external surface of the product may be very hot. If used at the maximum permitted operating conditions the surface temperature of some products may reach temperatures of 350 °C (662 °F).

Many products are not self-draining. Take due care when dismantling or removing the product from an installation (refer to 'Maintenance instructions').

1.14 Freezing

Provision must be made to protect products which are not self-draining against frost damage in environments where they may be exposed to temperatures below freezing point.

1.15 Disposal

Unless otherwise stated in the Installation and Maintenance Instructions, this product is recyclable and no ecological hazard is anticipated with its disposal providing due care is taken.

Please visit the Spirax Sarco product compliance web pages

<https://www.spiraxsarco.com/product-compliance>

for up to date information on any substances of concern that may be contained within this product. Where no additional information is provided on the Spirax Sarco product compliance web page, this product may be safely recycled and/or disposed providing due care is taken. Always check your local recycling and disposal regulations.

1.16 Returning products

Customers and stockists are reminded that under EC Health, Safety and Environment Law, when returning products to Spirax Sarco they must provide information on any hazards and the precautions to be taken due to contamination residues or mechanical damage which may present a health, safety or environmental risk. This information must be provided in writing including Health and Safety data sheets relating to any substances identified as hazardous or potentially hazardous.

2. General product information

2.1 Description

The Spirax Sarco safeguard high limit control system is supplied set to cut-out at approximately 60 °C (140 °F) and is designed to protect plant from overheating. Note: the settings can easily be altered to initiate cut-out at anywhere between 0 °C (32 °F) and 100 °C (212 °F), see Section 4. The system comprises of a Type 130 control system coupled to a HL10 high limit cut-out unit complete with 2 m of capillary tube as standard (see Figure 1); other lengths are available on request up to a maximum length of 10 m, subject to extra cost.

Note: the Type 130 control system is only suitable for use with the HL10 high limit cut-out unit. Sensor pockets are available from Spirax Sarco and are essential for correct operation.

The system is designed for use with any one of the following 2-port or 3-port Spirax Sarco control valves:

Available types of control valve

Note: See the relevant Installation and Maintenance Instructions when coupling to any one of the control valves listed below:

SB, KA, KB and KC:- 2-port normally open valves.

SBRA, KX, KY and NSRA:- 2-port normally closed valves.

Note: These valves must be installed in a separate bypass pipeline unimpeded by any other control valve when used with the safeguard high limit control.

TW DN25, 40 and 50:- 3-port mixing/diverting valve.

Note: For additional information see the Technical Information Sheet TI-P073-03.

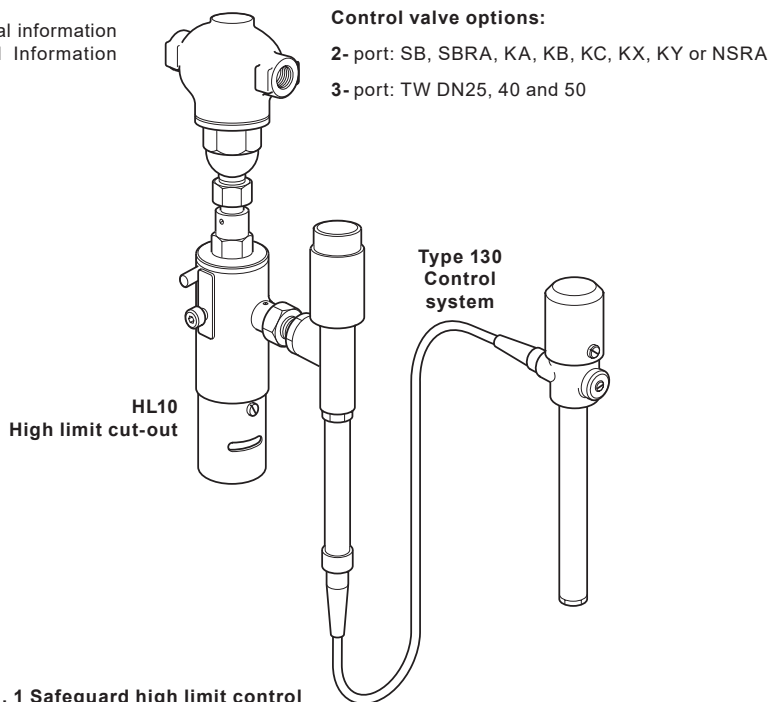

Type 130 and HL10 'Safeguard High Limit Control'

3. Installation

3.1 General

Check that the control system supplied is of the temperature range required. It is important that the whole of the temperature sensing area of the sensor is fully immersed in the fluid being controlled, see Figure 2.

The control system sensor should be located in a pocket and retained by means of a union nut and 'O' ring - **Do not overtighten the union nut.**

Connect the other end of the capillary system to the HL10 high limit cut-out unit.

Note: It is advisable to fill the gap between the pocket and the sensor with a heat conducting medium such as oil.

The capillary tube between the sensor and the HL10 actuator should be kept to a minimum length to avoid the system being affected by ambient temperature and must be run and supported in such a way that it will not become damaged. Avoid all sharp bends.

Prior to setting the system in operation some adjustment of the set temperature may be necessary (see Section 4).

Warning: The sensor must not be subjected to aqueous solutions containing chloride, fluoride and halogen.

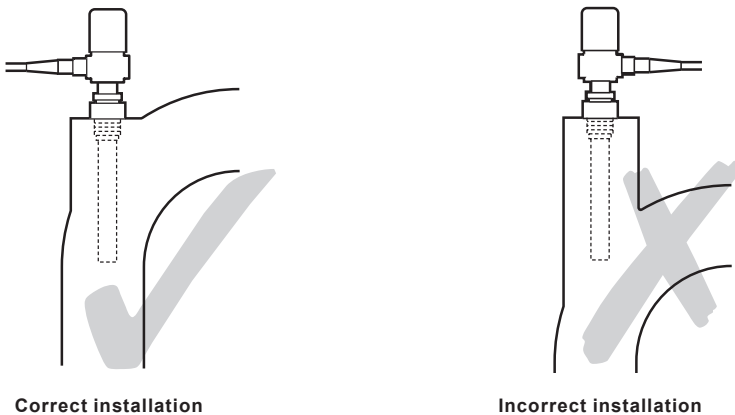

Fig. 2

3.2 Microswitch

When the optional microswitch (Figure 3) has been supplied with the safeguard high limit control system it can be connected into an alarm system using a Kopex conduit connector and flexible conduit (not supplied with the product). The microswitch can be arranged to either make or break the electrical circuit on firing of the cut-out.

The microswitch has a degree of protection to IP67 (dust tight and protected against the effects of immersion) under BS 5490.

Note: The microswitch can be added to an HL10 unit originally supplied without it by purchasing a conversion kit (see Section 7, Spare parts): which includes a conduit entry bracket and two screws for attachment.

Current rating table - Microswitch

Voltage	Load amps	
	Resistive	Inductive
125 Vac	5	5
250 Vac	5	5
up to 15 Vdc	10 10	
30 Vdc	5	3
50 Vdc	1	1
75 Vdc	0.75	0.25
125 Vdc	0.50	0.06
250 Vdc	0.25	0.03

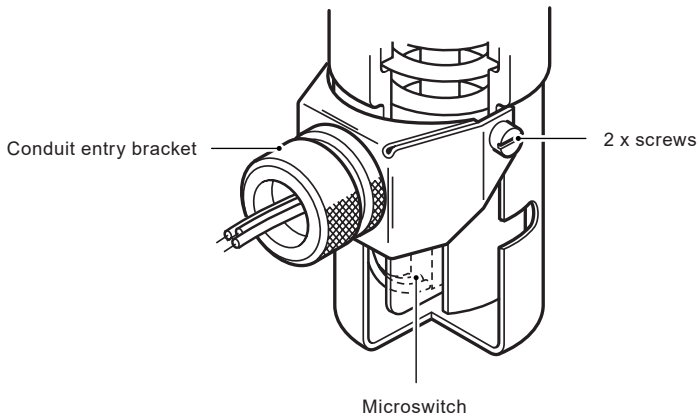

Fig. 3

3.3 Microswitch wiring

When the HL10 high limit cut-out unit is provided with a microswitch it has 3 colour coded wires (see Figure 4), black, grey and blue.

If on firing of the cut-out it is desired to energise the circuit, connect to the black and blue wires (grey is unused).

If on firing of the cut-out it is desired to break the circuit, connect to the black and grey wires (blue is unused).

Warning: The unused wires either, grey or blue, will become live during the operation of the switch and must be made electrically safe.

Earth: The unit should be suitably earthed through the yellow / green earth wire.

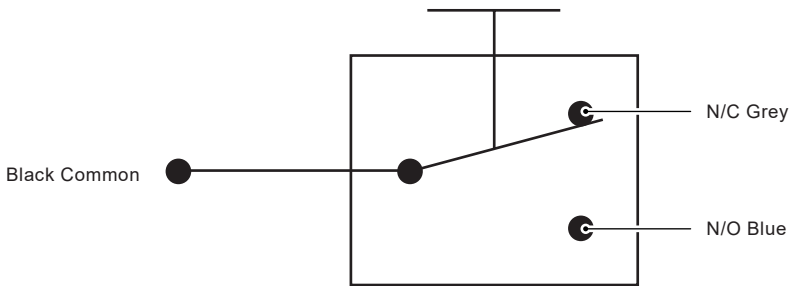



Fig. 4

Note: The unit is for installation category II (Overload category) and must be installed in accordance with IEC 60364 or equivalent. All connected circuits must have a common isolation system, which meets the relevant requirements of IEC 60947-1 and IEC 60947-3 or equivalent. It should be positioned close to the unit and clearly identified as the disconnected device.

3.4 Microswitch label information

250 V \sim 5 amps 50 - 60 Hz
 250 V \dots 250 mA (RESISTIVE)

**SEE INSTALLATION INSTRUCTIONS
 BEFORE CONNECTING SUPPLY**



**Isolate supply before removing
 Made in UK**

3.5 Compliance with EN 61010 - 1: 2001 para. 6.3.1 a

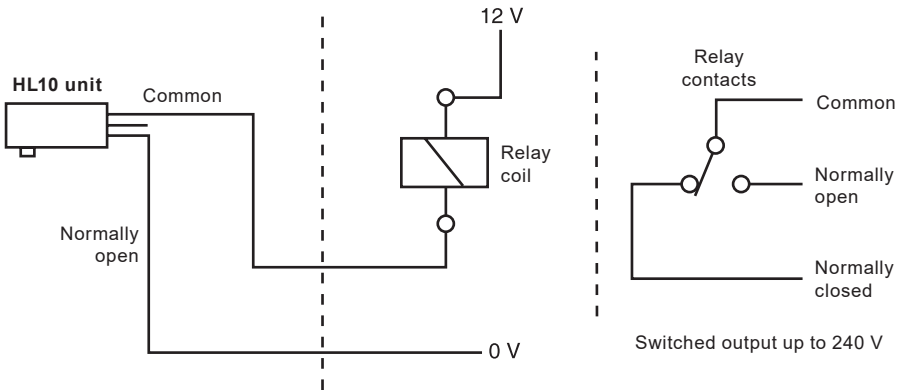

It is recommended that the microswitch is used in the above configuration when using a relay for voltages above 33 V rms or 70 Vdc.

4. Setting and adjustment

Ensure that the system is connected to the selected control valve and make sure that the HL10 is in the 'set' position. If the HL10 requires setting see Section 6.3.

The Type 130 control system is supplied factory set to operate at approximately 60 °C (140 °F). However, to ensure correct functioning, it is essential that the operating temperature is reset on site to suit the working conditions.

This is done as follows:

- Remove the adjustment head cover (13, Figure 5) by undoing the two screws (L) and slacken the lock-nut (M).

Note: If the required operating temperature is above 60 °C (140 °F) turn the setting screw (N) seven full turns in an anticlockwise direction before proceeding.

- Bring the equipment being controlled up to its normal operating temperature and allow it to settle for at least 10 minutes.
- Slowly turn the setting screw (N) in a clockwise direction until the HL10 is fired off.
- The setting screw (N) should then be turned in an anticlockwise direction one or two turns (1 turn = 6 °C (10.8 °F)) to give a margin between the normal operating temperature and the temperature at which the safeguard high limit control will come into operation.
- Finally reset the HL10 by following the procedure laid down in Section 6.3.

Note: do not forget to refit the adjustment head by securing the 2 x screws (L).

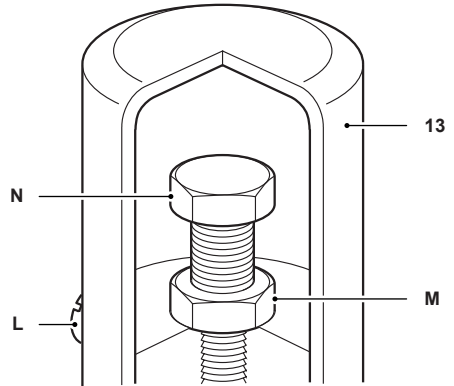

Fig. 5

5. Operation

The HL10 high limit cut-out unit can be triggered by any Spirax Sarco control system but when used with the Type 130 control it forms the 'Safeguard high limit control system' protecting plant from overheating.

When the cut-out has fired to operate the valve, a red disc (R, Figure 6) will appear in the indicator housing and the HL10 will need resetting (see Section 6.3).

6. Maintenance

6.1 General

The safeguard high limit control system is an entirely sealed unit and requires no maintenance. If damaged or if through fair wear and tear it requires attention, it can be returned to our works for overhaul. It is recommended that this system is tested frequently to ensure that it will operate satisfactorily when required to do so.

6.2 Testing

As an emergency device it is essential to test this unit frequently to ensure it will operate satisfactorily when required to do so. This should be done either by temporarily raising the temperature of the plant being controlled or by adjusting down the temperature at which the cut-out is normally set to operate.

Do not forget to reset to the correct temperature after the test (see Section 6.3)!

Note: A warning label is affixed to the outside of the indicator housing.

Warning: The cut-out device is spring loaded and should not be opened up by unskilled personnel nor should it be 'fired' other than when attached to the control valve.

6.3 Resetting

Before resetting investigate the cause of the override, and take remedial action if necessary. To reset allow the plant to cool down to normal operating temperature then using a tommy bar as a lever between the two lugs (S) and (T), see Figure 6, recompress the spring

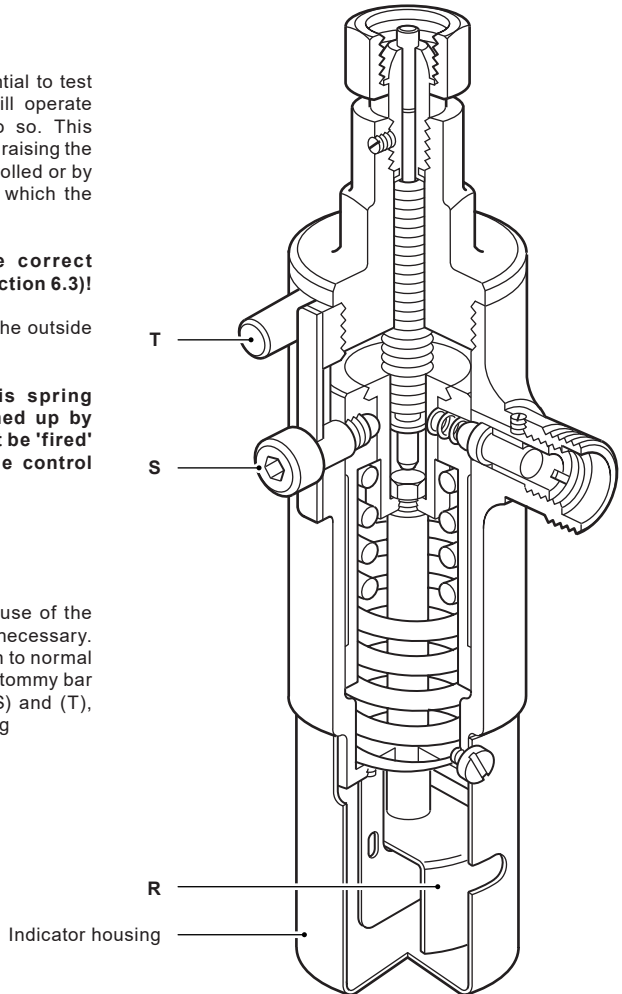

7. Spare parts

The spare parts available are shown in heavy outline. Parts drawn in a grey line are not supplied as spares.

Available spares

Microswitch assembly	A, B (2 off)
Conversion kit	A, B (2 off), C (2 off), D
Pack of warning labels	(6 off)

How to order spares

Always order spares by using the description given in the column headed 'Available spares' and state the type of high limit cut-out.

Example: 1 - Microswitch assembly for a Spirax Sarco HL10.

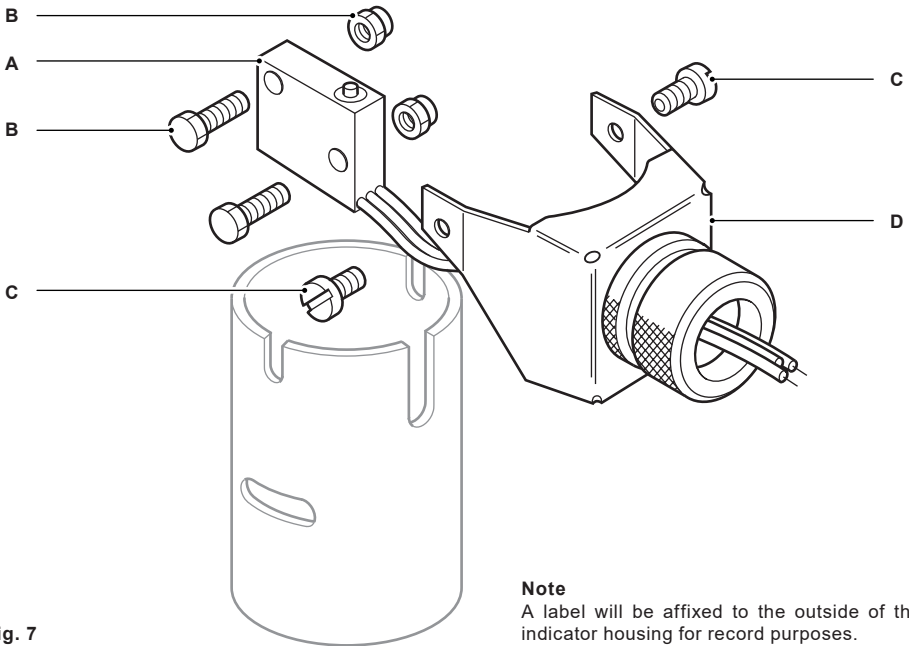

Fig. 7