

## TVA Flowmeter for Saturated Steam Service

### Installation and Maintenance Instructions

---

---

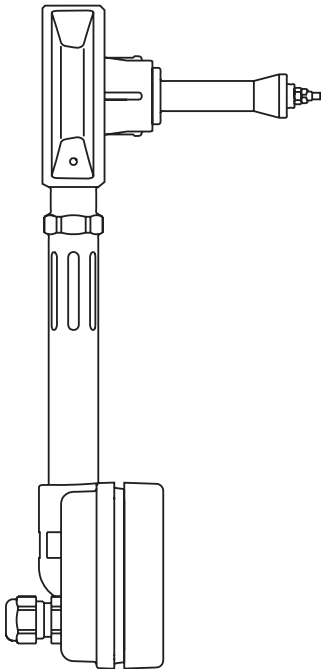

1. Safety information
2. General product information
3. Installation
4. Commissioning
5. Operation
6. Maintenance
7. Spare parts
8. Fault finding
9. Settings table

# 1. Safety information

Safe operation of this unit can only be guaranteed if it is properly installed, commissioned and maintained by a qualified person (see Section 1.11) in compliance with the operating instructions. General installation and safety instructions for pipeline and plant construction, as well as the proper use of tools and safety equipment must also be complied with.

## Manufacturer:-

Spirax Sarco Ltd  
Charlton House  
Charlton Kings  
Cheltenham  
Glos  
GL53 8ER

The product is designed and constructed to withstand the forces encountered during normal use. Use of the product for any other purpose, or failure to install the product in accordance with these Installation and Maintenance Instructions, could cause damage to the product, will invalidate the  marking, and may cause injury or fatality to personnel.

## EMC directive

The product complies with the Electromagnetic Compatibility Directive 2004/108/EC. A technical file with a reference number of 'UK Supply TVA flowmeter' supports the Spirax Sarco claim that the product complies with the requirements of the Directive and the product can be used in Class A (heavy industrial) and Class B (domestic/ commercial areas).

The following conditions should be avoided as they may create interference above the heavy industrial limits if:

- The product or its wiring is located near a radio transmitter.
- Cellular telephones and mobile radios may cause interference if used within approximately 1 metre (39") of the product or its wiring. The actual separation distance necessary will vary according to the surroundings of the installation and the power of the transmitter.

If this product is not used in the manner specified by this IMI, then the protection provided may be impaired.

## 1.1 Intended use

Referring to the Installation and Maintenance Instructions, name-plate and Technical Information Sheet, check that the product is suitable for the intended use/application.

The product listed complies with the requirements of the European Pressure Equipment Directive 2014/68/EU, carries the  mark when so required.

The product falls within the following Pressure Equipment Directive categories:

Product	Group 2 Gases	Group 2 Liquids
TVA flowmetering system DN50 to DN200	1	-

- i) The product has been specifically designed for use on saturated steam only which is in Group 2 of the above mentioned Pressure Equipment Directive.
- ii) Check material suitability, pressure and temperature and their maximum and minimum values. If the maximum operating limits of the product are lower than those of the system in which it is being fitted, or if malfunction of the product could result in a dangerous overpressure or overtemperature occurrence, ensure a safety device is included in the system to prevent such over-limit situations.
- iii) Determine the correct installation situation and direction of fluid flow.
- iv) Spirax Sarco products are not intended to withstand external stresses that may be induced by any system to which they are fitted. It is the responsibility of the installer to consider these stresses and take adequate precautions to minimise them.
- v) Remove protection covers from all connections and protective film from all name-plates, where appropriate, before installation on steam or other high temperature applications.

## 1.2 Access

Ensure safe access and if necessary a safe working platform (suitably guarded) before attempting to work on the product. Arrange suitable lifting gear if required.

## 1.3 Lighting

Ensure adequate lighting, particularly where detailed or intricate work is required.

## 1.4 Hazardous liquids or gases in the pipeline

Consider what is in the pipeline or what may have been in the pipeline at some previous time. Consider: flammable materials, substances hazardous to health, extremes of temperature.

## 1.5 Hazardous environment around the product

Consider: explosion risk areas, lack of oxygen (e.g. tanks, pits), dangerous gases, extremes of temperature, hot surfaces, fire hazard (e.g. during welding), excessive noise, moving machinery.

## 1.6 The system

Consider the effect on the complete system of the work proposed. Will any proposed action (e.g. closing isolation valves, electrical isolation) put any other part of the system or any personnel at risk?

Dangers might include isolation of vents or protective devices or the rendering ineffective of controls or alarms. Ensure isolation valves are turned on and off in a gradual way to avoid system shocks.

## 1.7 Pressure systems

Ensure that any pressure is isolated and safely vented to atmospheric pressure. Consider double isolation (double block and bleed) and the locking or labelling of closed valves. Do not assume that the system has depressurised even when the pressure gauge indicates zero.

## 1.8 Temperature

Allow time for temperature to normalise after isolation to avoid the danger of burns and consider whether protective clothing (including safety glasses) is required.

## 1.9 Tools and consumables

Before starting work ensure that you have suitable tools and/or consumables available. Use only genuine Spirax Sarco replacement parts.

## 1.10 Protective clothing

Consider whether you and/or others in the vicinity require any protective clothing to protect against the hazards of, for example, chemicals, high/low temperature, radiation, noise, falling objects, and dangers to eyes and face.

## 1.11 Permits to work

All work must be carried out or be supervised by a suitably competent person.

Installation and operating personnel should be trained in the correct use of the product according to the Installation and Maintenance Instructions.

Where a formal 'permit to work' system is in force it must be complied with. Where there is no such system, it is recommended that a responsible person should know what work is going on and, where necessary, arrange to have an assistant whose primary responsibility is safety.

Post 'warning notices' if necessary.

## 1.12 Handling

Manual handling of large and/or heavy products may present a risk of injury. Lifting, pushing, pulling, carrying or supporting a load by bodily force can cause injury particularly to the back. You are advised to assess the risks taking into account the task, the individual, the load and the working environment and use the appropriate handling method depending on the circumstances of the work being done.

### 1.13 Residual hazards

In normal use the external surface of the product may be very hot. If used at the maximum permitted operating conditions the surface temperature of some products may reach temperatures of 250 °C (482 °F).

Many products are not self-draining. Take due care when dismantling or removing the product from an installation (refer to 'Maintenance instructions').

### 1.14 Freezing

Provision must be made to protect products which are not self-draining against frost damage in environments where they may be exposed to temperatures below freezing point.

### 1.15 Disposal

Unless otherwise stated in the Installation and Maintenance Instructions, this product is recyclable and no ecological hazard is anticipated with its disposal providing due care is taken.

Please visit the Spirax Sarco product compliance web pages

<https://www.spiraxsarco.com/product-compliance>

for up to date information on any substances of concern that may be contained within this product. Where no additional information is provided on the Spirax Sarco product compliance web page, this product may be safely recycled and/or disposed providing due care is taken. Always check your local recycling and disposal regulations.

### 1.16 Returning products

Customers and stockists are reminded that under EC Health, Safety and Environment Law, when returning products to Spirax Sarco they must provide information on any hazards and the precautions to be taken due to contamination residues or mechanical damage which may present a health, safety or environmental risk. This information must be provided in writing including Health and Safety data sheets relating to any substances identified as hazardous or potentially hazardous.

## 2. General product information

This manual explains how to install, commission and maintain the Spirax Sarco TVA flowmeter for use on saturated steam.

### 2.1 Product description

The Spirax Sarco TVA flowmeter is designed to reduce the cost of flowmetering and is used as an accurate means to measure saturated steam flowrates and record total flow. The TVA flowmeter is a stand alone device and requires no other equipment, such as differential pressure transmitters, pressure sensors, etc. to calculate mass flowrates of saturated steam.

### 2.2 Equipment delivery and handling

#### Factory shipment

Prior to shipment, the Spirax Sarco TVA flowmeter is tested, calibrated and inspected to ensure proper operation, including the wired communications.

#### Receipt of shipment

Each carton should be inspected at the time of delivery for possible external damage. Any visible damage should be recorded immediately on the carrier's copy of the delivery slip.

Each carton should be unpacked carefully and its contents checked for damage.

If it is found that some items have been damaged or are missing, notify Spirax Sarco immediately and provide full details. In addition, damage must be reported to the carrier with a request for their on-site inspection of the damaged item and its shipping carton.

#### Storage

If a flowmeter is to be stored prior to installation, the environmental storage conditions should be at a temperature between 0 °C and 55 °C (32 °F and 131 °F), and between 10% and 90% relative humidity (non-condensing).

### 2.3 Sizes and pipe connections

DN50, DN80, DN100, DN150 and DN200

The TVA flowmeter is of a wafer design, suitable for fitting between the following flanges:

EN 1092 PN16, PN25 and PN40

BS 10 Table H

ASME B 16.5 Class 150 and 300

Korean Standard KS 20.

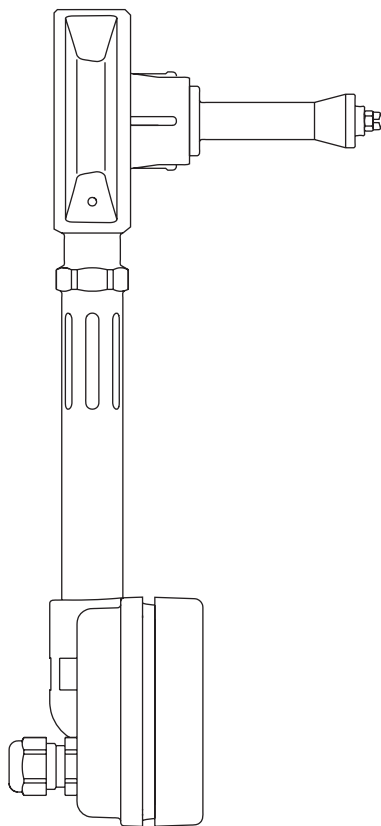
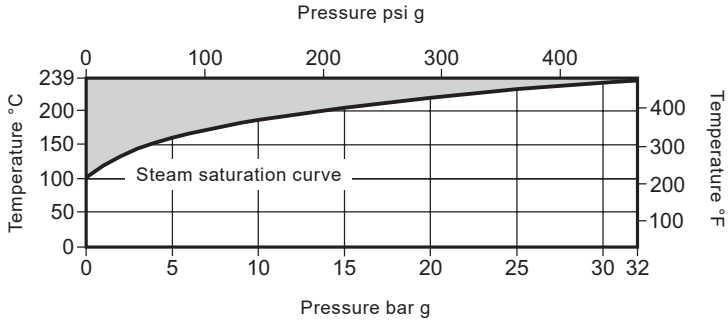

Fig. 1 TVA flowmeter

## 2.4 Pressure/temperature limits



The product should not be used in this region due to the limitations of the software.

PMA	Maximum allowable pressure @ 239 °C (462 °F)	Saturated steam 32 bar g (464 psi g) otherwise as the specified flange rating	
TMA	Maximum allowable temperature	239 °C	(462 °F)
	Minimum allowable temperature	0 °C (non-freezing)	(32 °F non-freezing)
PMO *	Maximum operating pressure for saturated steam service	Horizontal flow	32 bar g (464 psi g)
		Vertical flow	7 bar g (101 psi g)
	Minimum operating pressure	0.6 bar g	(8.7 psi g)
TMO	Maximum operating temperature	239 °C	(462 °F)
	Minimum operating temperature	0 °C (non-freezing)	(32 °F non-freezing)
	Maximum electronics ambient temperature	55 °C	(131 °F)
	Maximum electronics humidity level	90% RH (non-condensing)	
ΔPMX	Maximum differential pressure	The pressure drop across the TVA flowmeter at the maximum rated flow is nominally 750 m bar (300 inches wg) for the DN50, and 500 m bar (200 inches wg) for the DN80 and DN100	
	Cold hydraulic test pressure of:	52 bar g	(754 psi g)

TVA Flowmeter for Saturated Steam Service

**spirax**  
**sarco**

**\* Important note**

**Caution:** If the electronic housing is mounted at an angle of 45° (or more) from the vertically downward position the PMO (maximum operating pressure) must be limited to 7 bar g (101 psi g).

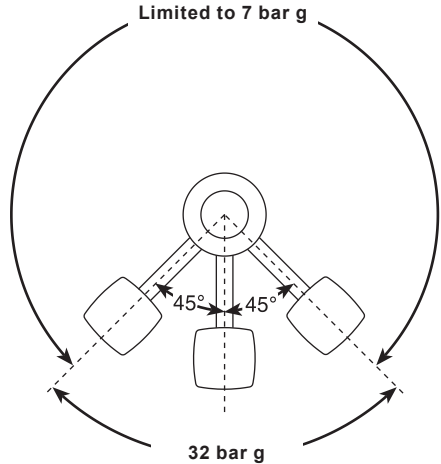

**Fig. 2 Installation limiting conditions**

**2.5 Technical data**

IP rating	IP65 with correct cable glands.
Power supply	Loop powered nominal 24 Vdc
Outputs	4-20 mA (proportional to mass flow) Pulsed output $V_{max}$ 28 Vdc, $R_{min}$ 10 k $\Omega$ , $V_{on}$ 0.7 $V_{max}$
Communication port	EIA 232C 15 m limit - See Section 4.11
Performance	$\pm 2\%$ of reading over the range of 10% to 100% of maximum rated flow System uncertainty to ISO 17025 (95% confidence to 2 STD) $\pm 0.2\%$ FSD from 2% to 10% of maximum rated flow Turndown: up to 50:1

**2.6 Electrical connections**

Electrical connections	M20 x 1.5
------------------------	-----------



## 2.7 Materials

Flowmeter body	Stainless steel 1.4408 CF8M
Internals	431 S29/S303/S304/S316
Spring	Inconel® X750 or equivalent
Flowmeter stem	Stainless steel 431 S29
Electronics housing	Aluminium alloy LM 25

## 2.8 Dimensions/weights (approximate) in mm and kg

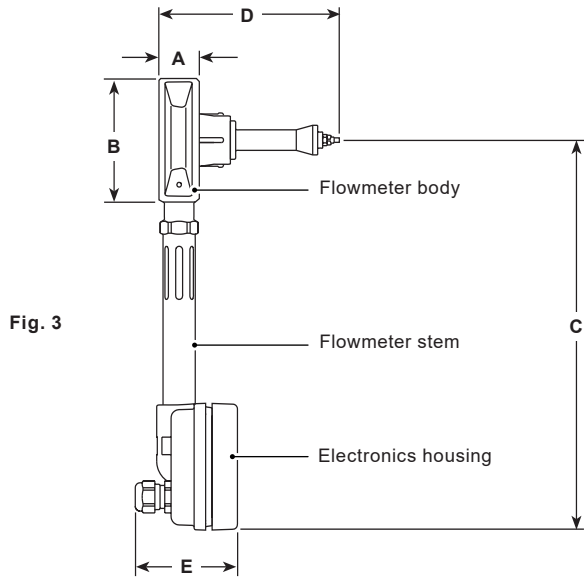

Size	A	B	C	D	E	Weight
DN50	35	103	322	160	65	2.67
DN80	45	138	334	160	65	4.38
DN100	60	162	344	215	65	7.28

# 3. Installation

**Note:** Before actioning any installation observe the 'Safety information' in Section 1. To meet its specified accuracy and performance it is essential that the following installation guidelines are followed carefully. For steam applications sound steam engineering practices should be followed, including the use of separators. The installation must conform to all relevant construction and electrical codes.

**Caution:** If the electronic housing is mounted at an angle of 45° (or more) from the vertically downward position the PMO (maximum operating pressure) must be limited to 7 bar g (101 psi g) - see Figure 4.

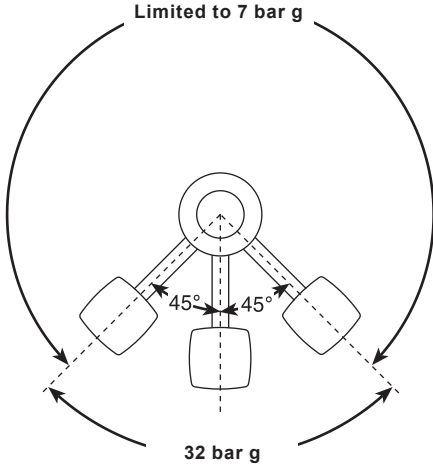

**Fig. 4**  
Installation limiting conditions

A bypass line will enable safe removal of the TVA flowmeter for maintenance or calibration. Closing valves **V1** and **V2** and opening valve **V3** will allow the TVA flowmeter to be isolated for re-zeroing (temperature to be <20 °C).

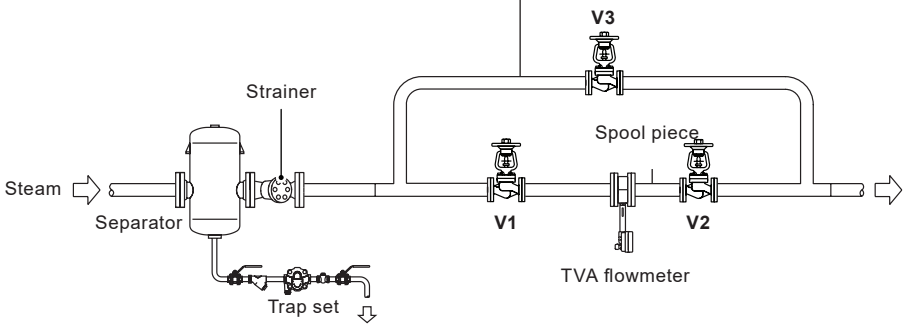

**Fig. 5** Typical installation

### 3.1 Environmental conditions

The flowmeter should be located in an environment that minimises the effects of heat, vibration, shock and electrical interference. (Pressure / temperature limits are detailed in Section 2.4).

**CAUTION: Do not lag (insulate) the TVA flowmeter or mating flanges as this may result in excessive temperatures in the electronics. Exceeding specified temperature limits will invalidate the warranty, adversely effect the performance and may damage the TVA flowmeter, see Figure 6.**

#### Other considerations

Be sure to allow sufficient clearance for:

- Installation of conduit/wiring.
- Removal of the electronics enclosure cover.
- Viewing of the display. **Note** electronics housing and display can be rotated.

**Warning: Do not install the flowmeter outdoors where it can be subjected to adverse weather conditions like driving rain or where it can freeze.**

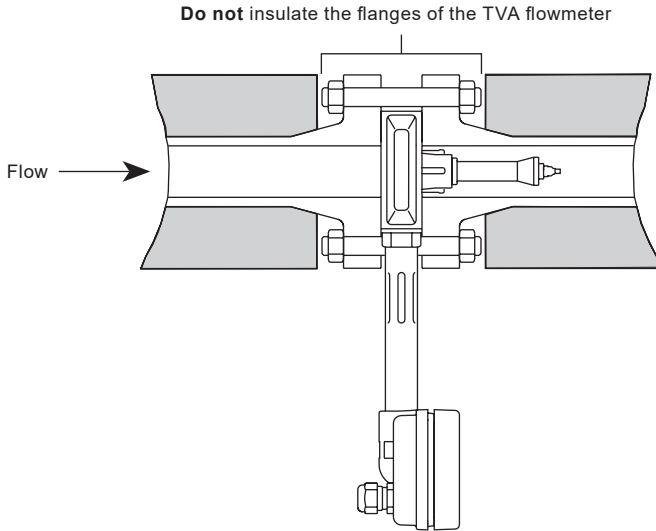

Fig. 6 Pipeline insulation

### 3.2 Mechanical installation

**Warning:** Do not alter the adjustment nut at the back of the TVA flowmeter shaft, as this will affect the flowmeters calibration.

#### Orientation

The TVA flowmeter can be installed in any orientation when the pressure is below 7 bar g (101 psi g), see Figures 7, 8 and 9.

When the pressure is above 7 bar g the TVA flowmeter must be installed in a horizontal pipe, with the electronics housing below the body, see Figure 9.

**Note:** The TVA flowmeter operates with flow in one direction only. It is not intended for use with bi-directional flow. The TVA flowmeter is clearly marked with a direction of flow arrow.

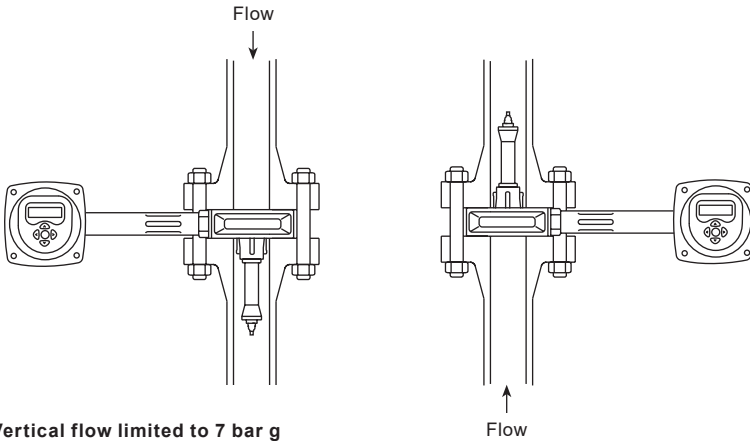

Fig. 7 Vertical flow limited to 7 bar g

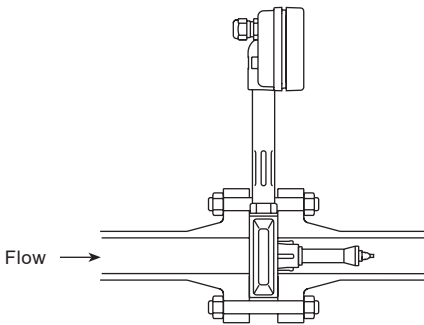

Fig. 8 Horizontal flow limited to 7 bar g

**Caution:** If the electronic housing is mounted at an angle of 45° (or more) from the vertically downward position the PMO (maximum operating pressure) must be limited to 7 bar g (101 psi g) - see Figure 4.

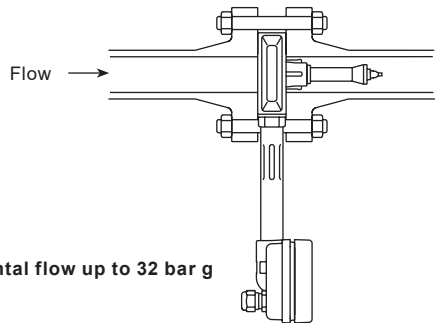

Fig. 9 Horizontal flow up to 32 bar g

### Rotating the electronics enclosure

The electronics housing can be rotated 270° to enable sufficient clearance for installation. To rotate the electronics housing, loosen the 6 mm grub screw located on the rear of the electronics housing (see Figure 10). The electronics housing can now be rotated to the required position.

When the electronics housing has been located into the correct position retighten the grub screw to a torque of 1.3 N m (11.5 lbf in).

**Warning: Do not loosen/remove the stem from the main body of the unit.**

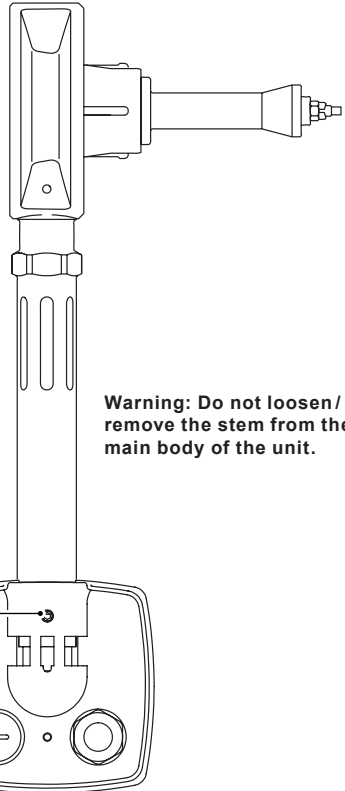

Fig. 10

6 mm grub screw

### Upstream/downstream pipework

The TVA flowmeter should be installed in pipework manufactured to BS 1600, ASME B 36.10 Schedule 40 or EN 10216-2 / EN 10216-5 equivalent, which corresponds to the following pipeline internal diameters:

For different pipe standards/schedules, if the flowmeter is being operated at the extreme of its published maximum range, and maximum accuracy is required, downstream spool pieces manufactured from pipe to the above standard should be used. It is important that the internal upstream and downstream diameters of pipe are smooth.

Ideally seamless pipes should be used and there should be no intrusive weld beads on the internal diameter. It is recommended that slip-on flanges be used to avoid any intrusive weld beads on the internal diameter of the pipe.

**Note:** See Figures 11 to 14 for other considerations which need to be noted before determining the correct installation location.

Nominal diameter	Nominal internal diameter
50 mm	52 mm
80 mm	77 mm
100 mm	102 mm
150 mm	mm
200 mm	mm

The TVA flowmeter normally only requires a minimum of 6 pipe diameters upstream and 3 downstream of clear straight pipe. These dimensions assume a measurement from a single 90° bend (see Figure 11).

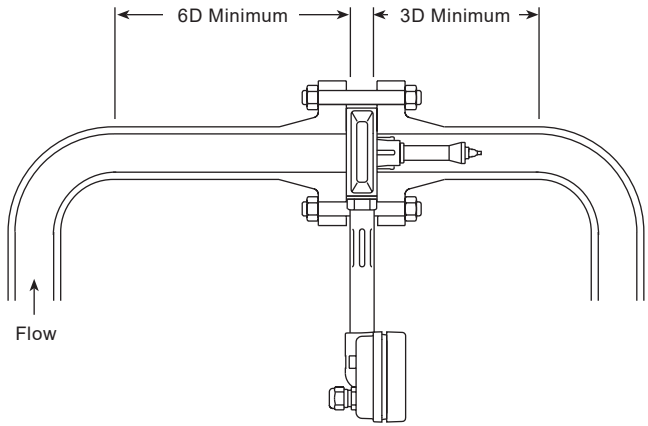

Fig. 11

If any of the following configurations are present upstream of the TVA flowmeter:

- Two right angled bends in two planes.
- Pressure reducing valve.
- Partly open valve.

Then it is recommended that the minimum upstream clear pipework is doubled to 12 diameters (See Figure 12).

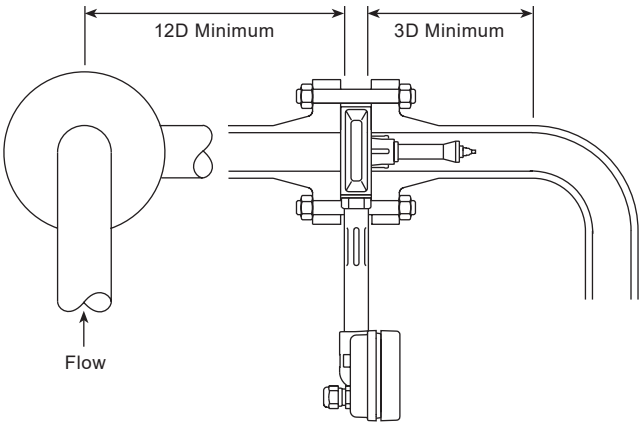

Fig. 12

Avoid installing the TVA flowmeter downstream of an actuated valve as rapid cycling of the valve could give rise to inaccurate results or damage the flowmeter. See Figure 13. In configurations where there is more than one rapid acting pressure reducing valve close coupled, the TVA flowmeter should be installed with a minimum of 25 upstream and 3 downstream pipe diameters away from the valves. Safety valves should also be as far away as possible from the flowmeter - at least 25D.

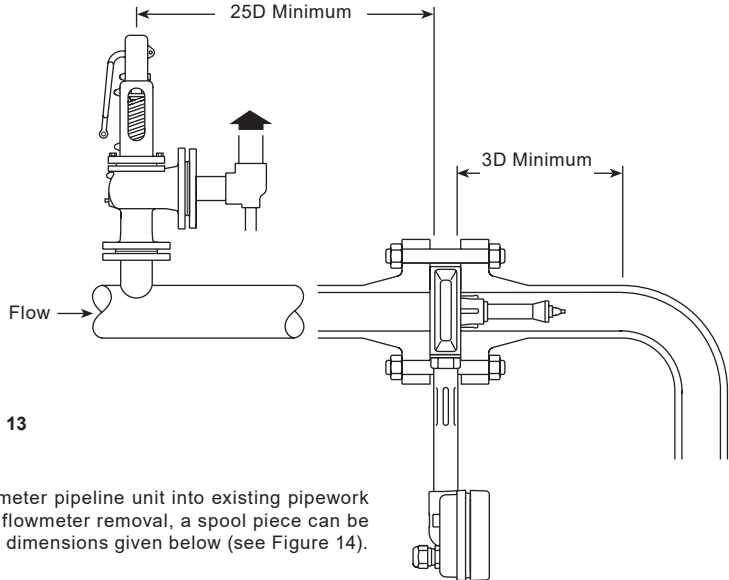

Fig. 13

To install the TVA flowmeter pipeline unit into existing pipework and for aiding possible flowmeter removal, a spool piece can be fabricated locally to the dimensions given below (see Figure 14).

Size	DN50	DN80	DN100
Dimension	180 mm	240 mm	300 mm
A	7.1 in	9.5 in	11.8 in

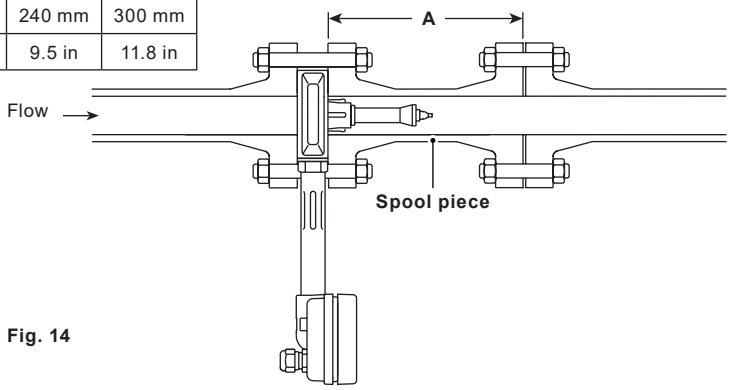

Fig. 14

TVA Flowmeter for Saturated Steam Service

## Location in pipework

Bolt ring gaskets having the same internal diameter of the pipework are recommended. This will prevent possible inaccuracies being created by the gasket protruding into the pipe.

It is important that the TVA flowmeter is located centrally in the pipework as any eccentricity may cause inaccurate readings. The TVA flowmeter has integral centering webs, which locate on the internal diameter of the pipe (see Figure 15).

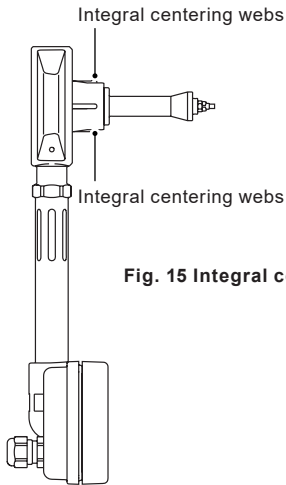

**Fig. 15 Integral centering webs**

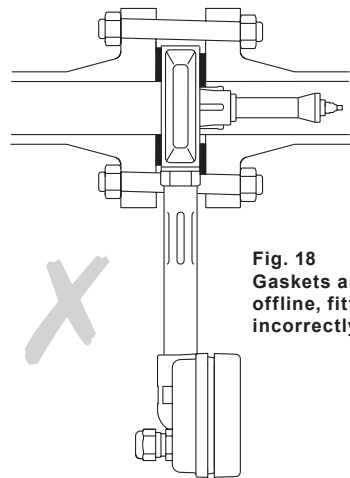
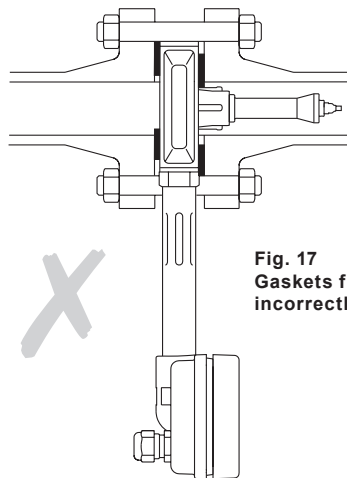
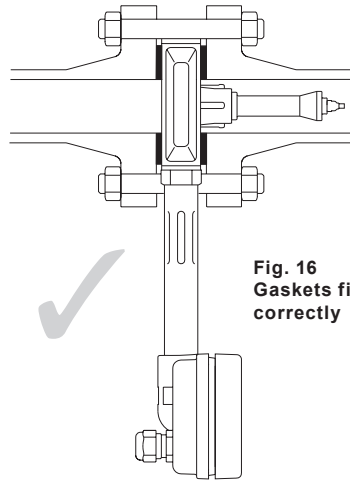



### 3.3 Electrical installation

The TVA flowmeter is a loop powered device. This Section describes loop wiring and shows typical conductor terminations (The EIA 232C (RS 232) wiring is discussed in Section 4.11). It also considers the effect of connecting additional equipment (e.g. recorder, loop powered display) to the loop.

#### Wiring the TVA flowmeter

The wiring terminals can be accessed by removing the end cap of the enclosure. A typical loop wiring diagram is shown in Figure 19.

If an M750 display unit is purchased from Spirax Sarco for use with the TVA flowmeter, the M750 must be configured to the flow of the TVA flowmeter @ 20 mA. If the TVA flowmeter 4 - 20 mA output is rescaled (see Section 4.6.1), it is important that the 20 mA input valve on the M750 is also rescaled.

**Notes: The flowmeter must be earthed. The TVA is supplied with a 1 metre earthing lead attached to a 4 mm threaded hole at the rear of the enclosure close to the 20 mm conduit holes. An alternative earth cable can also be attached. Please ensure all paint is removed to ensure a low resistance connection is made. The earth cable should be at least 1.5 mm sq and the use of a crimp is recommended. Remove the silica gel from the enclosure after commissioning.**

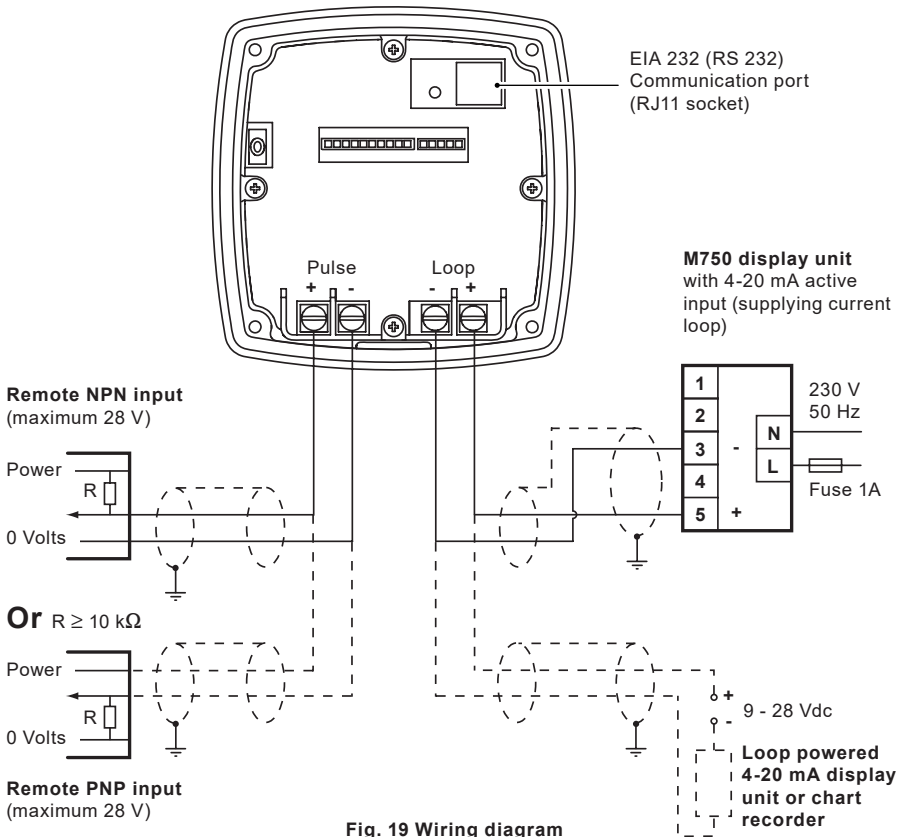

Fig. 19 Wiring diagram

## Power supply requirements

A nominal 24 Vdc is needed to power the flowmeter. However, the TVA flowmeter will operate correctly as long as the power supply is in the range shown in Figure 20. A single, stand-alone, supply may be capable of powering several transmitters. It can be mounted in a control room or in the field, but cannot be on the same loop. Follow the power supply manufacturer's recommendations with regard to mounting and environmental considerations.

The graph (Figure 20) shows the range of power supply voltages and loop resistances over which the TVA flowmeter is capable of operating. The loop resistance includes all the wiring.

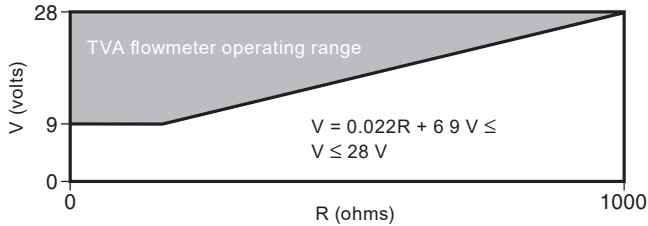

Fig. 20

## Cable length

Generally the maximum cable length between the TVA flowmeter and the power supply is 300 m (984 ft). However the actual cable length is governed by the number of network devices, the total resistance of the network and the cable capacitance.

**Suggested cable type:** for both loop and pulse should be shielded twisted pairs, each core, seven stranded wire with cross sectional area of 0.5 mm<sup>2</sup>.

Cable glands suitable for M20 x 1.5 to EN 50262 / IP68 are recommended.

The cable gland / body torque setting is 5 N m (3.68 lbf ft).

The gland nut torque setting (with cable fitted) is 5 N m (3.68 lbf ft).

## 4. Commissioning

After all mechanical and electrical work has been completed, the following commissioning instructions should be followed.

**The TVA flowmeter should be commissioned with the flow through the unit isolated.**

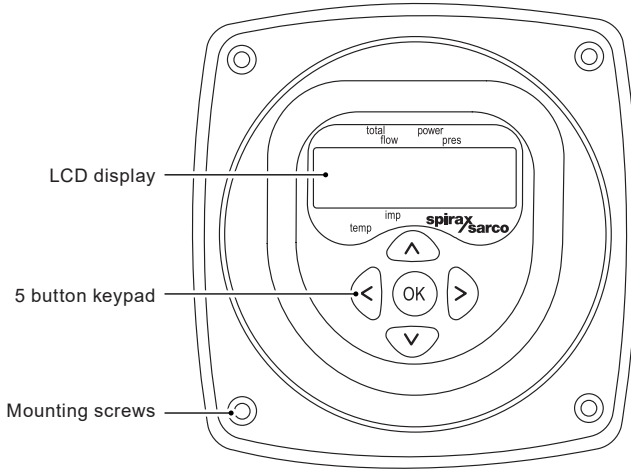

**Note:** The TVA flowmeter is factory set to display data in metric units. To commission the TVA to display imperial units see Section 4.4.2.

**Fig. 21 TVA flowmeter display unit**

All commissioning is carried out through the display unit installed behind the front end cap of the TVA flowmeter enclosure. The display unit consists of a small LCD display and a 5 button key pad.

As all the commissioning settings are stored in a non-volatile memory, it is possible to connect a 9 V PP3 battery to the TVA flowmeter's 4 - 20 mA loop power supply and commission the unit uninstalled. However, the TVA flowmeter should still be zeroed in-line (see Section 4.5.3) and its operation checked. The M750 display unit can be used to provide a remote display function if required, utilising the linear output.

### Rotating the display

The display can be rotated through 180° to enable ease of commissioning. To rotate the display disconnect the power supply, remove the mounting screws on the display unit, carefully remove the display unit and rotate. Carefully replace the display unit and replace mounting screws. Do not force the display unit into position. Reconnect the power supply. **Note 1** - Electrostatic discharge (ESD) procedures should be followed while rotating the display.

**Note 2** - **DO NOT** remove the 10 way connector from the display.

## 4.1 Run mode

Normally, the TVA flowmeter will operate in the run mode, displaying the total flow, flow, power, pressure or temperature of the fluid passing through the pipeline.

After initial power up, the TVA flowmeter will automatically enter the run mode and all commissioning menus can be accessed from this mode. (See Section 4.2, Commissioning mode, for details on how to commission). In the run mode the fluid data is displayed on several screens which can be accessed by pressing the up or down keys. The display shows a numeric value and an arrow indicating the reading type, i.e. total flow, flow, power, pressure or temperature. All units (except °C) are implied with imperial or metric units being indicated by another arrow. The value of total flow is shown in two parts. The first five digits of the total flow will be displayed and after 10 seconds the following five digits will be displayed. To access the first five digits of total flow again it will be necessary to scroll up or down and return to the total flow display.

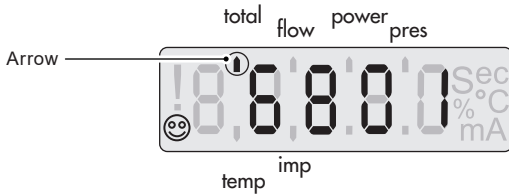

Fig. 22

### 4.1.1 Run mode data sequence

The following chart indicates the run mode data display sequence. Depending on the configuration, the flow units will be:

Units	Steam
Metric	Kg/h, KW, bar g, °C
Imperial	lb/h, MBtu/h, psi g, °F

The TVA flowmeter is factory set to display steam data in metric units and pressing the up or down keys will scroll through the following data.

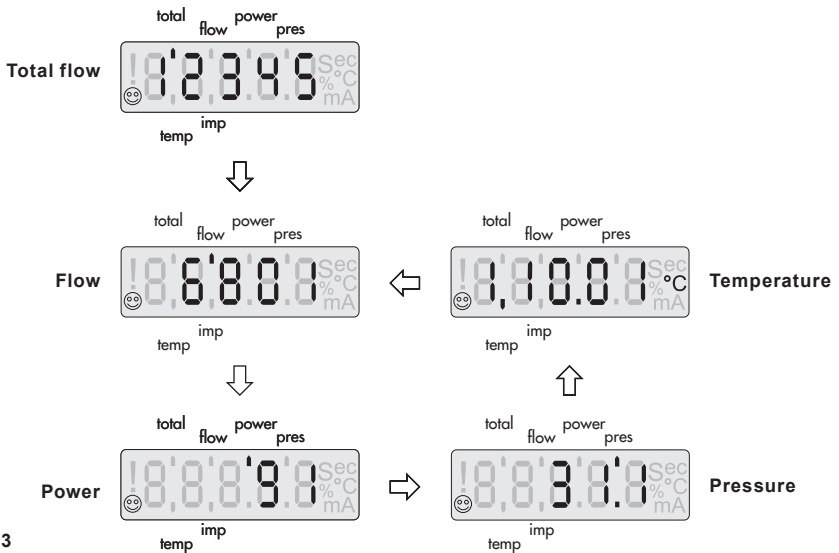
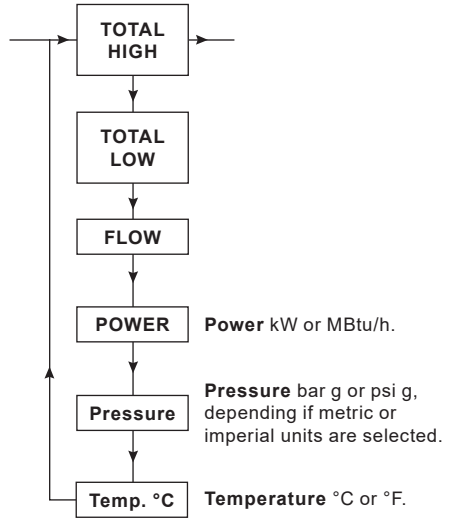

Fig. 23

### 4.1.2 Error display messages

Any errors that occur will be displayed in the run mode. The errors will alternate with the normal run mode display and will be prioritised. The errors will be latched and can only be cancelled by pressing the 'OK' button. Once the error message has been cancelled the display will show the next (if any) error.

Any continuous error will reinstate itself 2 seconds after it has been cancelled, and will be indicated by a flashing exclamation mark (!).

Certain errors will also cause the 4-20 mA alarm signal to be initiated.

The error messages are displayed over two screens and are:

- |                      |
|----------------------|
| <b>POWER<br/>OUt</b> |
|----------------------|

 = Power interrupted.
  
- |                     |
|---------------------|
| <b>NO<br/>SIGNL</b> |
|---------------------|

 = No signal from sensor.  
(This can also activate the 4-20 mA alarm).
  
- |                        |
|------------------------|
| <b>SENSR<br/>CONSt</b> |
|------------------------|

 = Signal from sensor constant.  
(This can also activate the 4-20 mA alarm).
  
- |                      |
|----------------------|
| <b>HIGH<br/>FLOW</b> |
|----------------------|

 = Flow above the maximum.

## 4.2 Commissioning mode

The commissioning mode is used to zero the flowmeter, re-range, set and test the outputs and change the pass code.

All data entry is performed via a menu and sub menu configuration with the key pad buttons used for navigation, i.e. to go deeper into the menu the right hand key is pressed, to scroll up and down the menu the up and down keys are pressed and to exit from a sub-menu the left key is pressed. Any data is entered using the OK button. The previously entered selection will flash. After a period of five minutes without any keys being pressed the TVA flowmeter will automatically default to the run mode.

For a full commissioning flow chart see Section 4.3.

To enter the commissioning mode press and hold down the 'OK' key for 3 seconds. The display then shows:

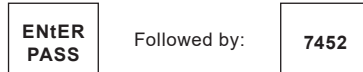

The leading digit will flash indicating that this is the position of the cursor.

The default factory set pass code is 7452. (This can be changed from within the commissioning mode). The pass code can be entered by using the up and down keys to increment the flashing value and the left and right keys to move the cursor. Pressing 'OK' will enter the pass code.

If an incorrect pass code is used the display will automatically return to the run mode.

After the correct pass code is entered the display shows:

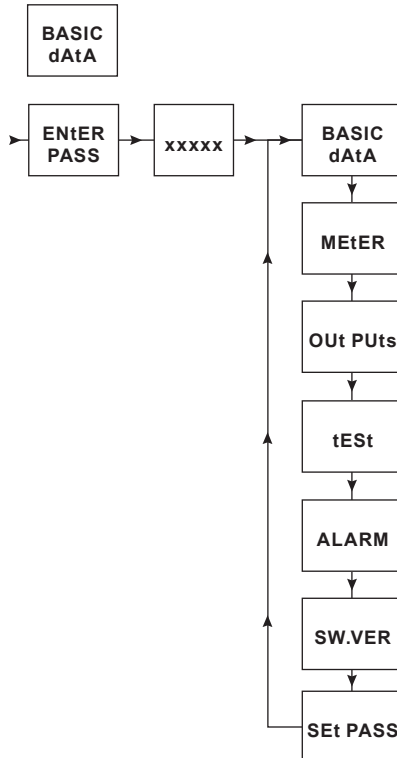

To exit from the commissioning mode at any stage, continually pressing the left key will return to the run mode.

Pressing the up and down buttons scrolls through the various first level menus.

Pressing the right arrow button enters a particular sub-menu.

### 4.3 TVA flowmeter commissioning flow chart

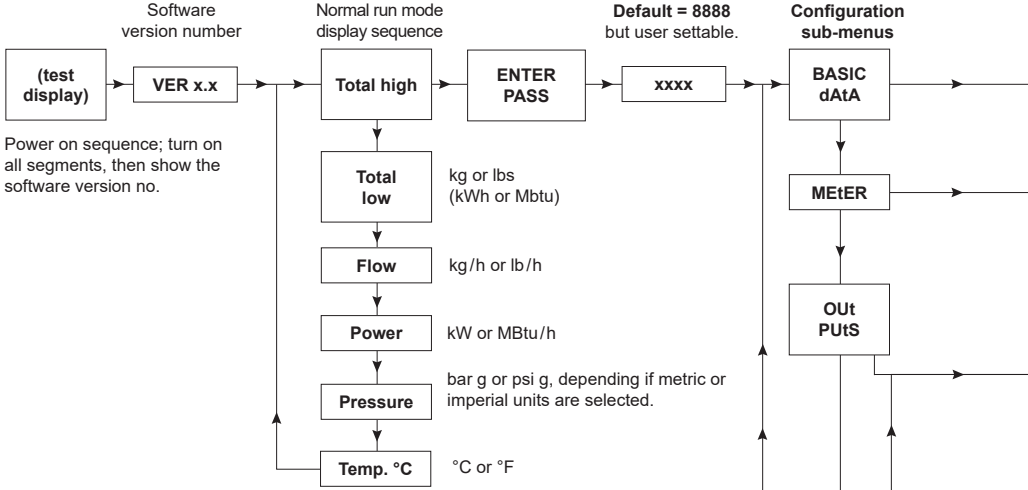

#### Error Messages

These alternate with the normal run mode display. They will be prioritised and will be latched when they occur. Pressing the 'OK' button will cancel the displayed alarm and allow the next one to be viewed. A continuous alarm will re-occur on the display 2 seconds after it has been cancelled.

Power interrupted	<b>POWER OUT</b>	
No signal from sensor	<b>NO SIGNAL</b>	The 4-20 mA alarm can also be activated
Signal from sensor constant	<b>SENSR CONST</b>	The 4-20 mA alarm can also be activated
Flow above maximum	<b>HIGH FLOW</b>	Shows when flow exceeds maximum

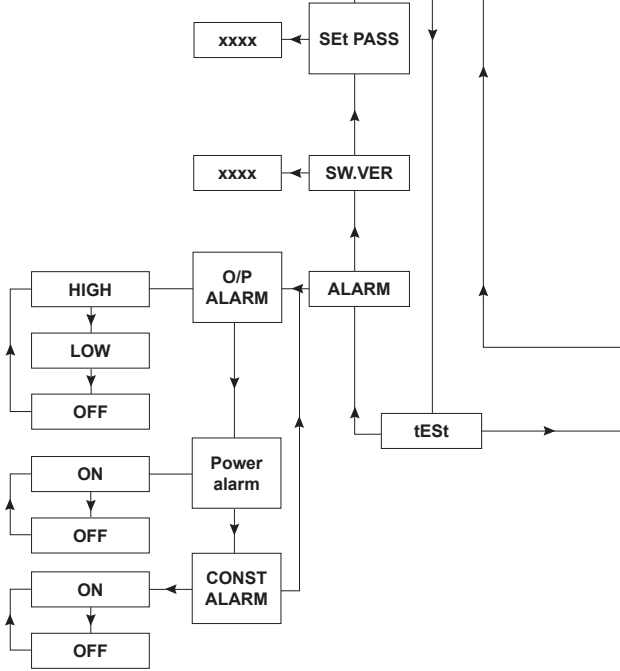



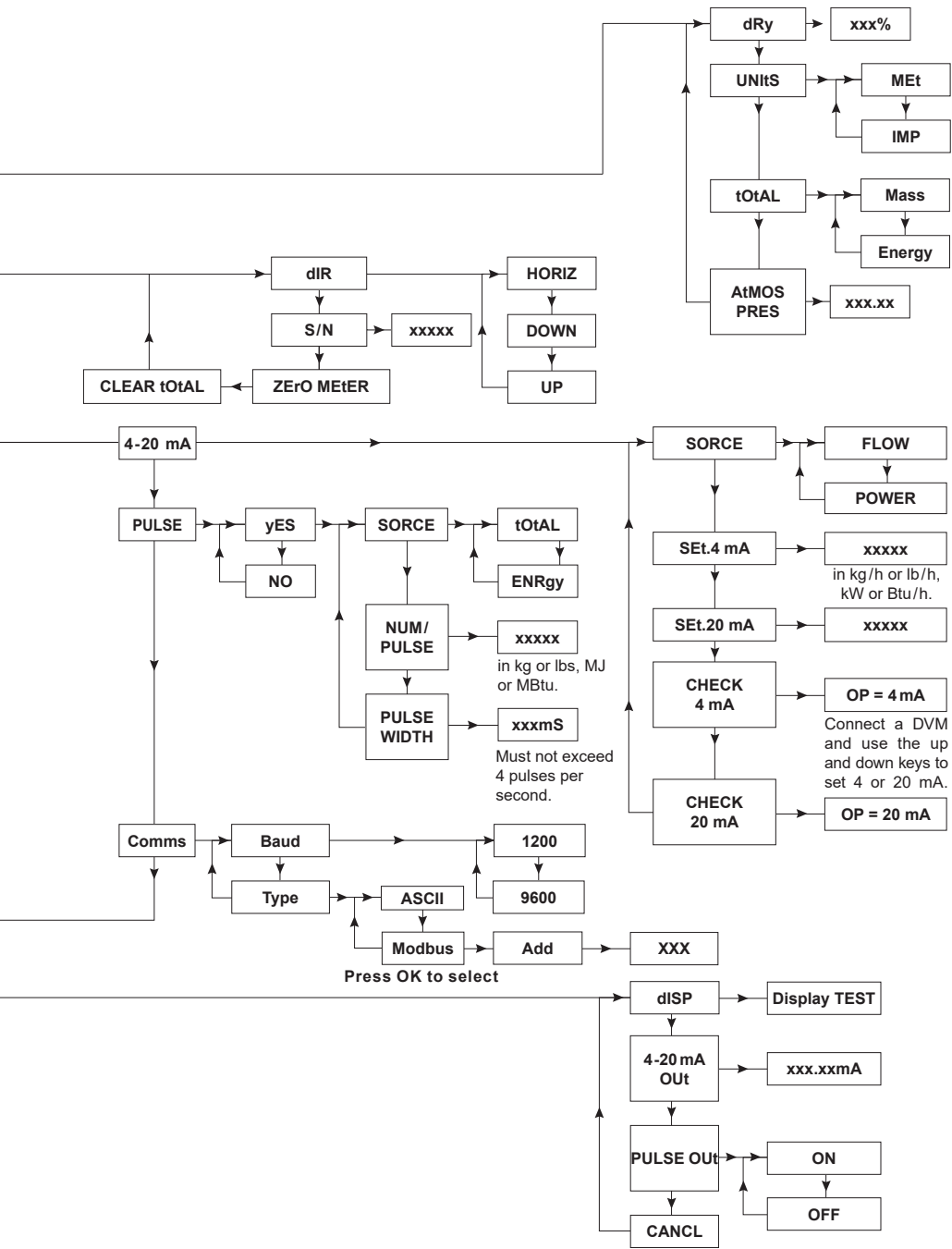

TVA Flowmeter for Saturated Steam Service



## 4.4 BASIC DATA Sub menu

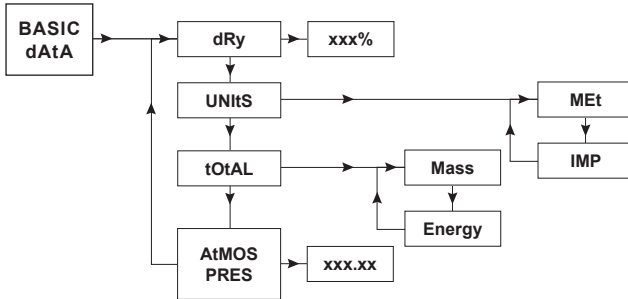

### 4.4.1 dRy

Pressing the right key will display the dryness fraction. This is the dryness fraction of the saturated steam being measured. This can then be edited to suit the application. Press the 'OK' button to confirm the selection. After the dryness fraction is entered the display will automatically step to the next sub menu and show 'UNItS'

### 4.4.2 UNItS

The units displayed and transmitted can be selected between metric (MEt), and imperial (IMP). A summary of the units is detailed in the Table below.

Units	Steam
Metric	Kg/h, KW, bar g, °C
Imperial	lb/h, MBtu/h, psi g, °F

Select either 'MEt' or 'IMP' and press the 'OK' button to confirm.

### 4.4.3 CLEAR tOtAL

This function is used to clear the total by pressing and holding the 'OK' key for 3 seconds.

**Note:** The total is backed-up every 8 minutes in the TVA flowmeter's non-volatile memory. If power is lost the TVA flowmeter could lose up to 8 minutes worth of totalised steam.

### 4.4.4 AtMOS PRES

This value compensates the flowrates for atmospheric pressure. It should be used if a high degree of accuracy is required or when the TVA flowmeter is installed high above sea level.

**Note:** Values up to two decimal places can be entered.

If metric units are selected pressure units are bar absolute, for imperial units psi absolute.

## 4.5 MEtER Sub-menu

This sub-menu contains information about the flowmeter and is used to zero the flowmeter and clear the total.

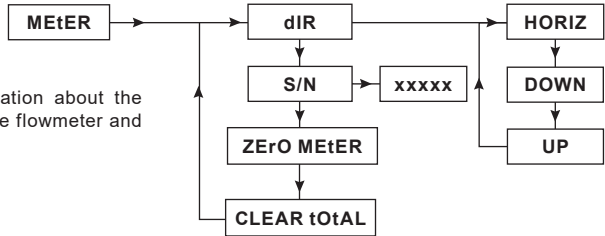

### 4.5.1 dIR

dIR is the orientation that the TVA flowmeter is installed in. The TVA flowmeter can be installed with horizontal flow up to a pressure of 32 bar g (464 psi g). For installations that require vertical flow either up or down the maximum pressure must not exceed 7 bar g (101 psi g). By selecting down or up the effect of gravity on the cone is taken into account.

**Note:** Upon entering the dIR sub-menu, HORIZ is **always** shown first. The actual direction selected is the one which is flashing.

### 4.5.2 S/N

This is the factory set serial number of the TVA flowmeter and is displayed by pressing the right key.

### 4.5.3 ZERo MEtER

This function is used to zero the TVA flowmeter manually to compensate for any electronic drift. The procedure for zeroing the flowmeter is as follows:

- Isolate the pipeline where the flowmeter is installed and ensure that there is no flow. The line temperatures should be above 5 °C (41 °F) and below 30 °C (86 °F).
- Press and hold the 'OK' button for three seconds.

On completion the display will step back to S/N.

If 'ZERo ErrOr' is displayed, check to ensure that the line is isolated with no flow.

If 'tEMP ErrOr' is displayed the line temperature is below 5 °C (41 °F). Allow the temperature to move above 5 °C (41 °F) and re-zero. **Note: The flowmeter should ideally be zeroed annually after 12 months service.**

### 4.5.4 CLEAR tOtAL

This function is used to clear the total by pressing and holding the OK key for 3 seconds.

**Note:** The total is backed-up every 8 minutes in the TVA flowmeter's non-volatile memory. If power is lost the TVA flowmeter could lose up to 8 minutes worth of totalised steam.

## 4.6 OutPutS Sub-menu

This sub-menu allows both the 4-20 mA and pulsed outputs of the flowmeter to be configured.

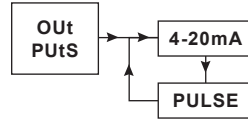

### 4.6.1 4-20 mA Output sub-menu

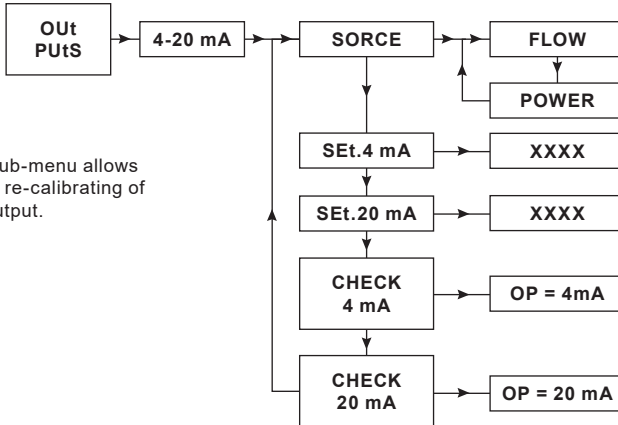

The 4-20 mA sub-menu allows re-ranging and re-calibrating of the 4-20 mA output.

### 4.6.2 SORCE

This changes the source data for the 4-20 mA between flow and power.

### 4.6.3 SEt 4 mA

This sets the value for the flowrate or power, which is equivalent to 4 mA. The minimum value that can be set as 4 mA is 0 and the maximum is the 20 mA equivalent value less one.

### 4.6.4 SEt 20 mA

This sets the value for the flowrate or power, which is equivalent to 20 mA. The minimum value that can be set as 20 mA is the 4 mA equivalent value plus one and the maximum is the meters rated maximum at 32 bar g. The 20 mA value must always be a minimum of one greater than the 4 mA value.

### 4.6.5 CHECK 4 mA

This allows the 4 mA value to be re-calibrated. A digital volt meter/multimeter should be connected in series with the 4-20 mA output. Pressing the right arrow button will display OP = 4 mA and the TVA flowmeter will output a steady 4 mA. If the multimeter does not read 4 mA the up and down arrow buttons can be pressed to alter this current until 4 mA exactly is indicated. Pressing the 'OK' button confirms the setting.

### 4.6.6 CHECK 20 mA

This allows the 20 mA value to be re-calibrated. A digital volt meter/multimeter should be connected in series with the 4-20 mA output. Pressing the right arrow button will display OP = 20 mA and the TVA flowmeter will output a steady 20 mA. If the multimeter does not read 20 mA the up and down arrow buttons can be pressed to alter this current until 20 mA exactly is indicated. Pressing the 'OK' button confirms the setting.

### 4.6.7 Pulse Output

This sub-menu allows the pulsed output to be configured.

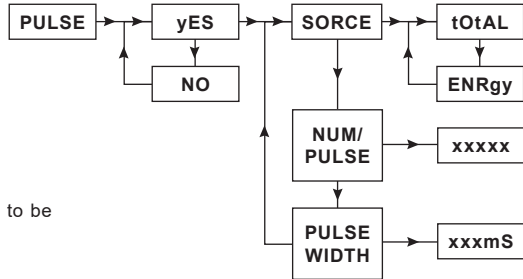

### 4.6.8 PULSE

This selects whether the pulsed output is to be used or disabled.

### 4.6.9 SOURCE

This selects the source data for the pulsed output. The source data can be either unit mass per pulse (tOTAL) or unit energy per pulse (ENRgy).

### 4.6.10 NUM/PULSE

This allows the total mass, or energy, which is equivalent to one pulse to be configured. Units are dependent on the UNIt setting. Metric units will be kg for total or MJ for energy, imperial units will be lb for total or MBtu for energy.

### 4.6.11 PULSE WIDTH

This allows the width of the pulse to be set. The width can be set in 0.01 second increments from 0.02 seconds to a maximum of 0.2 seconds.

### 4.6.12 Comms

This allows the connection to other communications protocols.

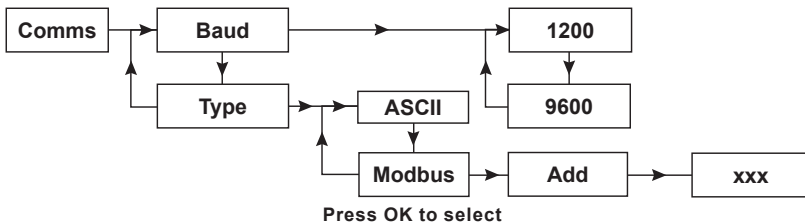

### 4.6.13 Baud

This allows the communication speed to be set to either 1200 or 9600. This must match the rate set within the device it is communicating to.

### 4.6.14 Type

This gives the choice to select either ASCII or Modbus protocols.

### 4.6.15 Add

If you have selected Modbus communications you must add an address. This is a three digit number between 001 - 255. Again this must match the address that the device that you are communicating to is set to.

## 4.7 tEst sub-menu

The tEst sub-menu allows access to the TVA flowmeter's diagnostic tools. From here the display, 4-20 mA and pulse outputs can be tested.

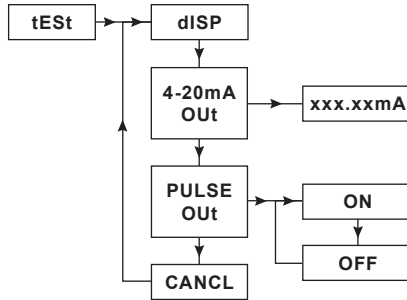

### 4.7.1 dISP

This allows the display to be tested. Pressing the right button will cause all the segments on the display to be turned on. Pressing the left button cancels the test and steps to the next stage.

### 4.7.2 4-20 mA Out

This allows the 4-20 mA output to be tested. By editing the value and pressing the 'OK' button the output can be set to the selected output. This current will continue to be transmitted for five minutes unless the cancel option is chosen.

### 4.7.3 PULSE OUT

This allows the pulsed output to be tested. By selecting 'ON' or 'OFF' the desired test state of the pulsed output can be selected. Once the 'OK' button is pressed the pulsed output will remain in the selected state for five minutes or until the cancel option is chosen.

### 4.7.4 CANCEL

This allows the 4-20 mA output and pulsed output test signal selected above to be cancelled before the five minutes duration has expired.

## 4.8 ALARM sub-menu

This sub-menu gives access to setting the action that is required on the 4-20 mA output when an error is detected by the TVA flowmeter electronics. It also gives access to the power alarm function.

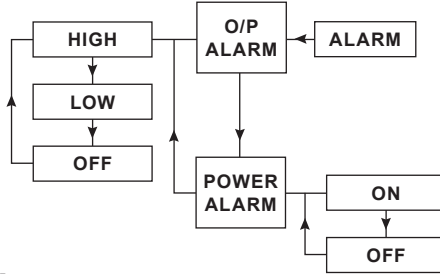

### 4.8.1 O/P ALARM

<b>HIGH</b>	If the self-diagnostic electronics determine that the sensor output has been constant for a period of time, or is not giving out a signal, it will set the 4-20 mA output to 22 mA.
<b>LOW</b>	If the self-diagnostic electronics determine that the sensor output has been constant for a period of time, or is not giving out a signal, it will set the 4-20 mA output to 3.8 mA.
<b>OFF</b>	This disables the 4-20 mA alarm function.

### 4.8.2 POWER ALARM

<b>OFF</b>	This disables the 4-20 mA alarm function (default).
<b>ON</b>	This enables the power alarm function.

### 4.8.3 CONSt ALARM

This allows the constant flow alarm to be turned off.

The constant alarm is switched to on by the default factory setting. It detects if the flow has been constant for long periods when at pressure, which may indicate a stuck cone due to debris. If the system that the TVA is fitted to, has long periods where there is zero flow, but the line is kept at a constant pressure, it is advisable to turn the alarm off to avoid unwanted alarm messages.

## 4.9 SW.VER

This allows the software version to be viewed.



## 4.10 Set PASS

This allows the default pass code to be changed to a user defined value. It is important that if the default pass code is changed that the new value is noted and kept safe.

The new pass code can be recorded on the Table in Section 9.

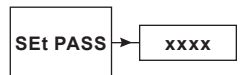

## 4.11 TVA communications

### 4.11.1 TVA UART set-up

The TVA flowmeter has an EIA 232C compatible communications link and supports two protocols: a simple Line Feed [LF] terminated ASCII protocol and a subset of Modbus/RTU. This enables users to easily interrogate the TVA flowmeter for steam data using either a dumb terminal or a P.C. loaded with a simple terminal emulation program or a standard Modbus Master / Client application. The connection length is limited to 15 metres and must be in the same building / area as the TVA flowmeter.

The TVA's communication set up should be as follows:

TVA ASCII set-up	
Baud rate	1200 or 9600
Data bits	7
Stop bits	one
Parity	none
Echo	off

TVA Modbus set-up	
Baud rate	1200 or 9600
Data bits	8
Stop bits	one
Parity	none
Echo	off

### Response time:

The TVA will start responding within 500 msec. The actual time to fully receive a response from the TVA is baud rate dependent, for example a Modbus poll of 12 registers @1200 baud rate could take  $((5 + 24) \text{ bytes} \times \sim 10 \text{ ms/byte}) + 500 \text{ ms} \approx 800 \text{ ms}$  to complete.

The polling frequency can be faster if the polling algorithm is set to poll immediately after receiving a valid response to a poll.

### 4.11.2 Using the EIA 232C communications

It is assumed that:

- The electrical wiring for the EIA 232C communications has been carried out in accordance with the EIA 232C standard. Please note the TVA EIA 232C connection requires a connector RJ11 linked to a 9 way D-type adaptor. Figure 24 illustrates the TVA flowmeter's RJ11 socket from the front.

The table below lists the RJ11 socket's pin connections. The signals are named from the PC (or data terminal) end.

RJ11 pin	9-way D-type	Signal
1		Not used
2 →	4	DTR
3 →	5	GND
4 →	2	RX
5 →	3	TX
6 →	8	CTS



Fig. 24 RJ11 socket



- The communications protocol has been set up on the communicating device as described earlier in this Section. The following is a Table of operating codes in ASCII characters:-

### ASCII communications

Please note that all the following commands are case sensitive...

User transmits	TVA responds by transmitting
AB[LF]	Pressure in BarG [LF]
AC[LF]	Line Temperature in Celsius [LF]
AH[LF]	Energy total in kWh [LF]
AP[LF]	Power in KW [LF]
AR[LF]	Flow rate in Kg/H [LF]
AT[LF]	Total in kg [LF]

### 4.12

**After installation or maintenance ensure that the system is fully functioning. Carry out tests on any alarms or protective devices.**

## 4.13 Modbus communications

The TVA flowmeter has Modbus communications, in addition to the ASCII Modbus comms that are available through the TVA RS232 port. An RS485 to RS232 converter is required, or alternatively, an Ethernet to RS232 converter, both of which are widely available.

### Modbus comms protocol

#### Format: Request frame

Address	1 byte
Function code	1 byte
Start address	2 bytes
Quantity of registers	2 bytes
Error check (CRC)	2 bytes
Total	8 bytes

#### Format: Response frame (normal)

Address	1 byte
Function code	1 byte
Byte count	1 byte
Register data	2 x Quantity of registers, MSB first, low register address first
Error check (CRC)	2 bytes
Total	5+ (2 x Quantity of registers) bytes

#### Format: Response frame (error)

Address	1 byte
Error code	1 byte (error code = function code plus 0x80)
Exception code	1 byte (01 or 02 see below)
Error check (CRC)	2 bytes
Total	5 bytes

**Note:** Only 'Read holding registers' (function code '03') is currently supported

#### 4.13.1 ModBus request frame structure example.

Byte 1	Byte 2	Byte 3	Byte 4	Byte 5	Byte 6	Byte 7	Byte 8
Device address	Function code	Register start address (MSB)	Register start address (LSB)	Register quantity (MSB)	Register quantity (LSB)	CRC (LSB)	CRC (MSB)
x	(3)	(0)	(0)	(0)	(12)	x	x

The above frame will poll all Modbus registers from Total low 16-bits up to and including Software Version.

Register number	Modbus address	Parameter	Received data scale	Units	Notes
40001	0	Total low 16 bits	x1	Kg	Total = (Total high x 65536) + Total low *
40002	1	Total high 16 bits	x1	Kg	
40003	2	Flow	x1	Kg/h	
40004	3	Pressure	x100	BarG	
40005	4	Temperature	x10	°C	
40006	5	Water equivalent flowrate	x10	L/hour	
40007	6	Power	x1	kW	
40008	7	Energy low 16 bits	x1	kWh	Energy = (Energy high x 65536) + Energy low *
40009	8	Energy high 16 bits	x1	kWh	
40010	9	Alarm status	-	(bit-fields)	Look table below
40011	10	SxS device ID	-	-	TVA = 0
40012	11	Software version	-	-	200 is sw ver 2.00, 201 is sw ver 2.01 etc
40021	20	Total low 16 bits	x1	Lbs	Total = (Total high x 65536) + Total low *
40022	21	Total high 16 bits	x1	Lbs	
40023	22	Flow	x1	Lbs/h	
40024	23	Pressure	x100	PSIg	
40025	24	Temperature	x10	°F	
40026	25	Water equivalent flowrate	x10	Lbs/hour	
40027	26	Power	x1	KBTU/h	
40028	27	Energy low 16 bits	x1	kBTU	Energy = (Energy high x 65536) + Energy low *
40029	28	Energy high 16 bits	x1	kBTU	

**Note** Modbus protocol requires that Modbus addresses start at offset 0, not 1. Register addresses start from 1 in description but 0 in binary. Most parameters are 16 bits and few parameters are 32 bits. Modbus registers are 16 bits, i.e. 1 device parameter needs 1x and 2x Modbus register(s) respectively. As a general note on Modbus, register types and reference register number ranges are implemented as follows:

0x = Coil = 00001 - 09999

1x = Discrete input = 10001 - 19999

3x = Input register = 30001 - 39999

4x = Holding register = 40001 - 49999

\* Multiply by the inverse 'Received Data Scale' to extract data in relevant units, i.e. divide polled 'Temperature' by 10 to get the value in °C...

Tip: use real (float) type to retain 2-decimal-point accuracy.

### TVA Flowmeter for Saturated Steam Service

### 4.13.2 Alarm status register bit-fields:

Bit	Set (1)	Cleared (0)
Bit 0 (0x0001)	Sub-saturation alarm is active	Sub-saturation alarm is idle
Bit 1 (0x0002)	Default	
Bit 2 (0x0004)	Pressure alarm is active (too high or too low)	Pressure alarm is idle
Bit 3 (0x0008)	-	-
Bit 4 (0x0010)	Hi flow alarm is active	Hi flow alarm is idle
Bit 5 (0x0020)	Sensor constant alarm is active	Sensor constant alarm is idle
Bit 6 (0x0040)	No signal from sensor alarm is active	No signal from sensor alarm is idle
Bit 7 (0x0080)	Power failed (has been turned off and on) alarm is active	Power failed alarm is idle
Bit 8 (0x0100)	Hi flow alarm has latched	-
Bit 9 (0x0200)	Sensor constant alarm has latched	-
Bit 10 (0x0400)	No signal from sensor alarm is latched	-
Bit 11 (0x0800)	Power failed alarm has latched	nothing
Bit 12 (0x1000)	-	-
Bit 13 (0x2000)	-	-
Bit 14 (0x4000)	-	-
Bit 15 (0x8000)	-	-

A maximum of 12 Modbus registers can be polled together at the same frame. It has to be noted that only a poll with a valid start address and quantity that falls within the supported register range will produce a normal frame response. If you ask for a frame with start address outside this range or a frame that the start address + quantity falls outside this range, the TVA will reply with an 'illegal data address' error message. If the function code is incorrect, it will reply with an 'illegal function' error message.

If a message is received with the wrong CRC, it will be ignored. The TVA response time is not instant (look below) so wait for it to reply before asking for more data, otherwise it will ignore new requests.

As the TVA is a loop powered instrument, it needs CTS and/or DTR to be wired into it so that it can use these to power its communications interface.

### 4.13.3 Response time:

The TVA will start responding within 500 msec. The actual time to fully receive a response from the TVA is baud rate dependent, for example a Modbus poll of 12 registers @1200 baud rate could take  $((5 + 24) \text{ bytes} \times 10 \text{ ms/byte}) + 500 \text{ ms} \approx 800 \text{ ms}$  to complete.

The polling frequency can be faster if the polling algorithm is set to poll immediately after receiving a valid response to a poll.

## 5. Operation

The TVA flowmeter operates by measuring the strain produced on a moving cone by an instantaneous flowrate. This strain is then converted into a density compensated mass flowrate and is transmitted via a single loop powered 4 - 20 mA output and pulsed output. The unique design of the TVA flowmeter produces the high turndowns and high accuracy required in process applications.

## 6. Maintenance

The TVA flowmeter should be zeroed using the zero meter sub-menu at least once a year. This will remove any electronic long term drift that may occur. Frequency of re-calibration depends upon the service conditions experienced by the meter and the application. Re-calibration frequency can be typically between 2 and 5 years.

### Replacement of the TVA flowmeter display electronics

To replace the electronics:

- Disconnect the power supply.
- Remove the front housing.
- Remove the mounting screws on the display unit and carefully remove the electronics.
- Carefully unplug the ribbon cable.
- Reconnect the ribbon cable to the new electronics and carefully replace.
- Replace the mounting screws and reconnect the power supply.

**Note:** Electrostatic discharge (ESD) procedures should be followed while installing the new electronics.

**Do not force the electronics/display unit into position.**

## 7. Spare parts

Spare electronics for the TVA flowmeter are available from Spirax Sarco and consist of:

- TVA flowmeter replacement display and electronics with front housing.

It is important that the serial number of the TVA flowmeter is given at the time of ordering.

**Example:** 1 off Spirax Sarco display and electronics panel for a DN100 TVA flowmeter having the following Serial number D\_\_\_\_\_.

## 8. Fault finding

Many faults which occur on commissioning are found to be due to incorrect wiring or setting up, therefore it is recommended that a thorough check is carried out should there be a problem. The TVA flowmeter display has in-built diagnostic features and will indicate a number of errors on the display and via the 4-20 mA output.

The errors will alternate with the normal run mode display and will be shown according to priority. The errors will be latched and can only be cancelled by pressing the 'OK' button. Once the error message has been cancelled the display will show the next (if any) error.

Any continuous error will re-instate itself 2 seconds after it has been cancelled, and will be indicated by a flashing exclamation mark (!).

Symptom	Possible cause	Action
<b>Display is blank</b>	dc voltage is not within the range of 9-28 Vdc.	Check power supply/current connections. See Section 3.3.
	Supply connected with reverse polarity.	Change polarity.
	Electronics faulty.	Refer to: Spirax-Sarco Limited
<b>Display shows: NO SIGNAL</b>	Insufficient supply voltage.	Check supply voltage is between 9 and 28 Vdc.
	Current loop resistance is greater than Rmax.	Check current loop resistance and reduce if necessary.
	Electronics faulty.	Check current output electronics (refer to Sections 4.6 and 4.7). Refer to: Spirax-Sarco Limited
<b>Display shows: POWER Out</b>	Power supply interrupted.	Ensure power supply is secure and cancel error using the OK key. Totals transmitted may not be valid.
<b>Display shows: SENSR CONST</b>	Cone jammed.	Remove unit from pipeline and check cone movement.
	Electronics Faulty.	Check current output electronics (refer to Sections 4.6 and 4.7). Refer to: Spirax-Sarco Limited
<b>Display shows: HIGH FLOW</b>	Meter undersized.	Check sizing and replace if necessary.
<b>Constant 3.8 mA</b>	Error signal set to Low.	Check display for errors and rectify as above.
		Check current output electronics (refer to Sections 4.6 and 4.7).

Symptom	Possible cause	Action
Constant 22 mA	Error signal set to High.	Check display for errors and rectify as above.  Check current output electronics (refer to Sections 4.6 and 4.7).
Flow indicated responds to changes in actual flow but value indicated does not correspond to actual flowrate	Flowmeter not properly centred in the pipeline.  Gaskets at the flowmeter protrude into the pipe bore.  Irregularities on the surface of the pipe bore.  Signal falsified due to bi-phase medium.  Insufficient upstream/downstream pipe lengths.  Flow direction reversed.	The axis of the flowmeter bore should be aligned with that of the pipe.  See Section 3, Figures 16, 17 and 18 for proper installation of gaskets.  Pipe bore should be free of irregularities.  Bi-phase media are not permitted. Use a separator for wet steam applications to remove moisture droplets from the steam.  See Section 3 for correct lengths of upstream and downstream pipes.  Check flow direction arrow on primary.
Pulse output is incorrect	Pulse output incorrectly set.  Pulse width incorrectly set.  Pulse output is overloaded.  Pulse output electronics faulty.	Check programming of pulse output, Section 4.6.7.  Check maximum pulse width of counter electronics.  Check load ratings.  Test pulse output. If faulty replace unit.
TVA produces large amount of noise (banging and clattering)	Upstream/downstream installation lengths incorrect.	Re-install following the installation guidelines (Section 3).
Non zero flow indicated when no actual flow is in the pipe.	Unit not zeroed at commissioning.  4 mA output not calibrated.  4 mA retransmission set to a value higher than zero.  Interference.	Zero unit.  Calibrate 4 mA output (Section 4.6.5).  Reset 4 mA.  Check earthing.

## 9. Settings table

This Table shows all changeable options, and enables records to be made of any changes made to the pass code or other settings. It provides a convenient reference should future changes be required.

Sub-menu	Changeable settings	Factory settings	Customer settings	Further changes
<b>Basic data</b>	Dryness fraction	1.0		
	Units	Metric		
	Nominal pressure			
	Atmospheric pressure	1.01 bar a		
<b>Outputs</b>	4-20 mA			
	Source data	Flow		
	4 mA setting	0		
	20 mA setting	Flowmeter maximum @ 32 bar g		
	Pulse	ON		
	Source data	Total		
	Number of pulses	1 per kg		
	Pulse width	50 mS		
<b>Error</b>		High		
<b>Pass code</b>		7452		