

spirax sarco

TN2000 Series Pneumatic Piston Actuators for DN15 to DN100 Spira-trol™ Series Control Valves Installation and Maintenance Instructions

1. Safety information
2. General product information
3. Installation
4. Commissioning
5. Spare parts

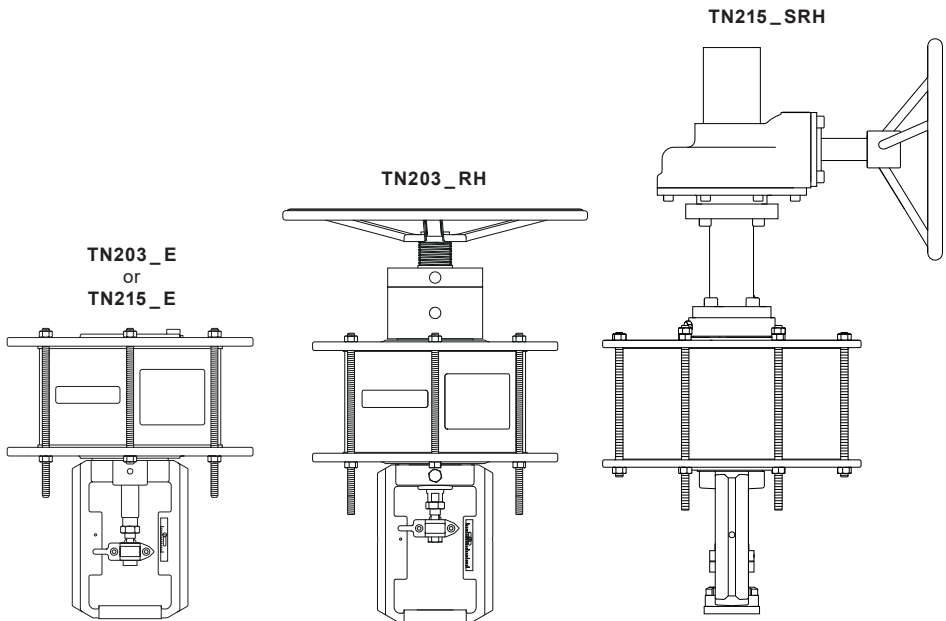

1. Safety information

Safe operation of this product can only be guaranteed if it is properly installed, commissioned, used and maintained by qualified personnel (see Section 1.11) in compliance with the operating instructions. General installation and safety instructions for pipeline and plant construction, as well as the proper use of tools and safety equipment must also be complied with.

1.1 Intended use

Referring to the Installation and Maintenance Instructions, name-plate and Technical Information Sheet, check that the product is suitable for the intended use/application. Please note that these products are out of the scope of the Pressure Equipment Directive (PED).

- i) This product has been specifically designed for use on compressed air, which is in Group 2 of the above mentioned Pressure Equipment Directive. The products' use on other fluids may be possible but, if this is contemplated, Spirax Sarco should be contacted to confirm the suitability of the product for the application being considered.
- ii) Check material suitability, pressure and temperature and their maximum and minimum values. If the maximum operating limits of the product are lower than those of the system in which it is being fitted, or if malfunction of the product could result in a dangerous overpressure or overtemperature occurrence, ensure a safety device is included in the system to prevent such over-limit situations.
- iii) Spirax Sarco products are not intended to withstand external stresses that may be induced by any system to which they are fitted. It is the responsibility of the installer to consider these stresses and take adequate precautions to minimise them.

1.2 Access

Ensure safe access and if necessary a safe working platform (suitably guarded) before attempting to work on the product. Arrange suitable lifting gear if required.

1.3 Lighting

Ensure adequate lighting, particularly where detailed or intricate work is required.

1.4 Hazardous liquids or gases in the pipeline

Consider what is in the pipeline or what may have been in the pipeline at some previous time. Consider: flammable materials, substances hazardous to health, extremes of temperature.

1.5 Hazardous environment around the product

Consider: explosion risk areas, lack of oxygen (e.g. tanks, pits), dangerous gases, extremes of temperature, hot surfaces, fire hazard and solvents.

1.6 The system

Consider the effect on the complete system of the work proposed. Will any proposed action (e.g. closing isolation valves, electrical isolation) put any other part of the system or any personnel at risk? Dangers might include isolation of vents or protective devices or the rendering ineffective of controls or alarms. Ensure isolation valves are turned on and off in a gradual way to avoid system shocks.

1.7 Pressure systems

Ensure that any pressure is isolated and safely vented to atmospheric pressure. Consider double isolation (double block and bleed) and the locking or labelling of closed valves. Do not assume that the system has depressurised even when the pressure gauge indicates zero.

1.8 Temperature

Allow time for temperature to normalise after isolation to avoid danger of burns.

1.9 Tools and consumables

Before starting work ensure that you have suitable tools and/or consumables available. Use only genuine Spirax Sarco replacement parts.

1.10 Protective clothing

Consider whether you and/or others in the vicinity require any protective clothing to protect against the hazards of, for example, chemicals, high/low temperature, radiation, noise, falling objects, and dangers to eyes and face.

1.11 Permits to work

All work must be carried out or be supervised by a suitably competent person.

Installation and operating personnel should be trained in the correct use of the product according to the Installation and Maintenance Instructions.

Where a formal 'permit to work' system is in force it must be complied with. Where there is no such system, it is recommended that a responsible person should know what work is going on and, where necessary, arrange to have an assistant whose primary responsibility is safety.

Post 'warning notices' if necessary.

1.12 Handling

Manual handling of large and/or heavy products may present a risk of injury. Lifting, pushing, pulling, carrying or supporting a load by bodily force can cause injury particularly to the back. You are advised to assess the risks taking into account the task, the individual, the load and the working environment and use the appropriate handling method depending on the circumstances of the work being done.

1.13 Residual hazards

In some cases the product is provided with pre-compressed springs. Any operation to open the spring housing is to be carried out strictly following the correct procedure as detailed in this document.

1.14 Freezing

Provision must be made to protect products which are not self-draining against frost damage in environments where they may be exposed to temperatures below freezing point.

1.15 Disposal

This product should not be dismantled without first releasing the compression on the spring (if fitted). This product is recyclable and no ecological hazard is anticipated with its disposal providing due care is taken, however the following list of exception will require individual disposal in line with local health and safety regulations:

- PTFE
- Polythene
- PVC
- Composite tube
- Nitrile NBR 70 shore 'O' rings and 'X' rings.

1.16 Returning products

Customers and stockists are reminded that under EC Health, Safety and Environment Law, when returning products to Spirax Sarco they must provide information on any hazards and the precautions to be taken due to contamination residues or mechanical damage which may present a health, safety or environmental risk. This information must be provided in writing including Health and Safety data sheets relating to any substances identified as hazardous or potentially hazardous.

2. General product information

2.1 Description

The TN2000 series of pneumatic piston actuators are suitable for use with DN15 to DN100 Spira-trol™ control valves of which three versions are available: Single-acting (with spring), Double-acting (with spring) and Double-acting (no spring). The availability of these three versions meets the requirements of valves at various differential pressures and in a variety of applications.

2.2 Technical data

Temperature range		-15 °C to +110 °C	(5 °F to 230 °F)
Maximum operating inlet pressure	TN203_	10 bar g	(145 psi g)
	TN2153 DE/DR		
	TN2150 DR/DE	5 bar g	(72 psi g)
	TN215N DA		
	TN2153 SR/SE	8 bar g	(116 psi g)
	TN2150 SE/SE	7 bar g	(101 psi g)
Air supply connection		1/4" or 3/8" screwed NPT	
Actuator travel	TN203_	30 mm	
	TN215_	50 mm	

2.3 Materials **Parts 1 to 14** (See page 8 for **parts 15 to 41**)

No.	Part		Material
1	Lower cylinder end cap		SG iron EN 1563 EN-GJS-400-15 : 5.3106
2	Piston		SG iron
3	Spring		Chrome vanadium steel
4	Upper cylinder end cap		SG iron EN 1563 EN-GJS-400-15 : 5.3106
5	Cylinder		Composite tube
6	'O' ring		Nitrile NBR 70 SH
7	Threaded bar	M8	Carbon steel (plated)
8	Nut	M8	Carbon steel (plated)
9	Screw slotted pan head	M2.5 x 12	Carbon steel (plated)
10	Yoke		SG iron
11	Front clamp		Stainless steel
12	Rear clamp		Stainless steel
13	Nut	M5	Carbon steel (plated)
14	Formed hex. screw	M5 x 16	Carbon steel (plated)

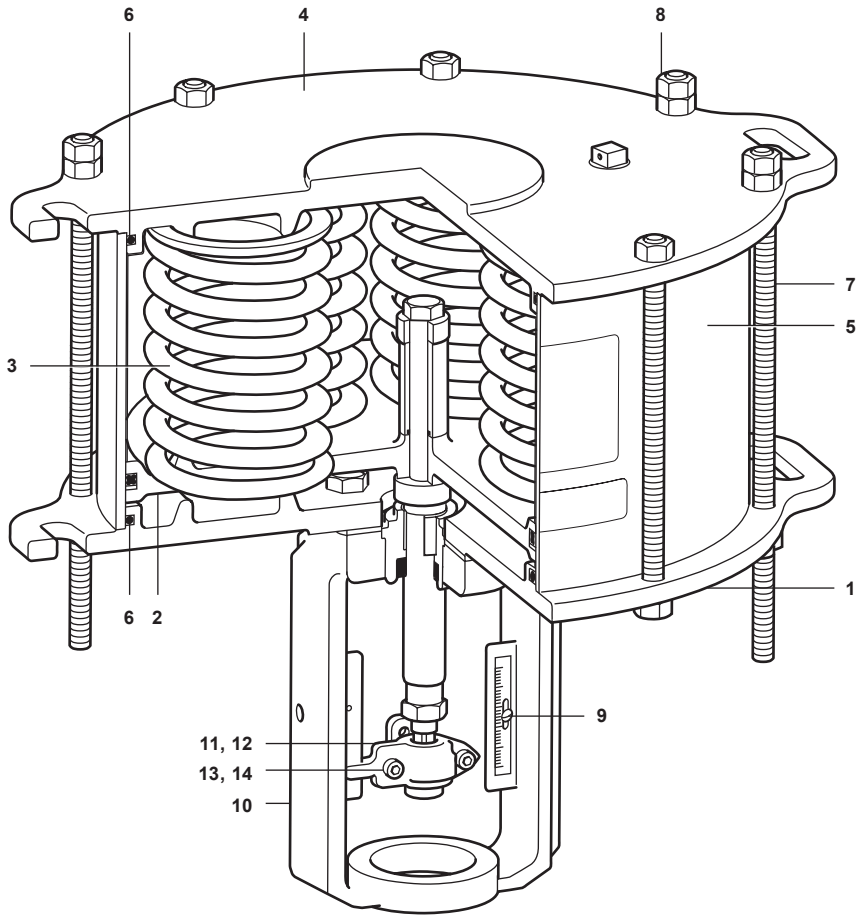
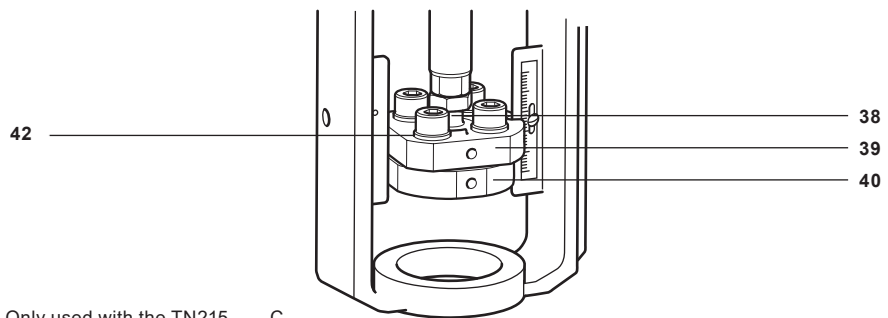
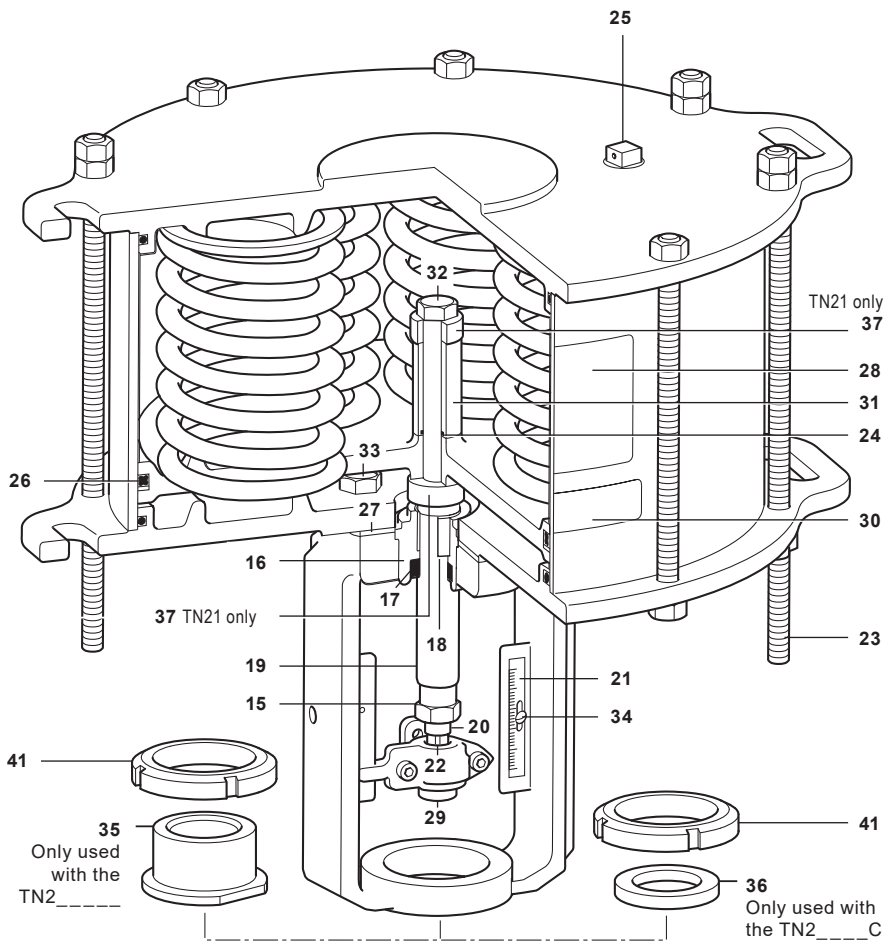

Fig. 1

2.3 Materials (continued) Parts 15 to 41 (See page 6 for parts 1 to 14)

No.	Part		Material
15	Nut	M12	Carbon steel (plated)
16	Bearing and seal insert		Carbon steel (plated)
17	Rod seal wiper	Ø20	Polyurethane
18	DU plain bearing	Ø20	PTFE/steel composite
19	Spindle		Stainless steel
20	Connector		Stainless steel
21	Scale		Stainless steel
22	Collar		Carbon steel (plated)
23	Threaded bar	M8 Long	Carbon steel (plated)
24	'O' ring	11.6 x 2.4	Nitrile NBR 70 SH
25	Vent plug	3/8" NPT	Polyamid 6.6
26	'X' ring		Nitrile NBR 70 SH
27	Gasket		Graphite seal
28	Label blank (Compressed spring warning)		Adhesive paper
29	Adaptor		Stainless steel
30	Label blank		Adhesive paper
31	Sleeve		Carbon steel (plated)
32	Formed hex. screw	M12	Carbon steel (plated)
33	Formed hex. screw	M12 x 25	Carbon steel (plated)
34	Nut	M2.5	Carbon steel (plated)
35	Yoke adapter		Stainless steel
36	Yoke sleeve		Stainless steel
37	Spindle sleeve (TN21 only)		Carbon steel (plated)
38	Connector DA		Stainless steel
39	Upper clamp DA		Stainless steel
40	Adaptor DA		Stainless steel
41	Thin valve nut		Carbon steel (plated)
42	Grower washer M10		Stainless steel



Only used with the TN215____ C

Fig. 2

Actuator data:

Actuator range	Travel	Thrust	Acting pressure 0 mm	Acting pressure 20 mm	Acting pressure 30 mm	Acting pressure 50 mm
TN2030 and variants	30 mm	2.5 kN 562 lbf	0.79 bar 11.50 psi	1.47 bar 21.31 psi	1.81 bar 26.24 psi	
TN2033 and variants	30 mm	6 kN 1349 lbf	1.89 bar 27.40 psi	4.19 bar 60.80 psi	5.34 bar 77.49 psi	
TN2150 and variants	50 mm	3.6 kN 809 lbf	0.46 bar 6.70 psi	1.12 bar 16.27 psi	1.45 bar 21.06 psi	2.11 bar 30.64 psi
TN2153 and variants	50 mm	14 kN 3147 lbf	1.95 bar 28.30 psi	2.73 bar 39.58 psi	3.12 bar 45.23 psi	3.90 bar 56.54 psi

Caution:

Those pressure ranges are estimated and directly related to the springs precision ($\pm 10\%$).

Furthermore, the working pressure with the valve coupled can be a little bit upper because of the friction inside of it.

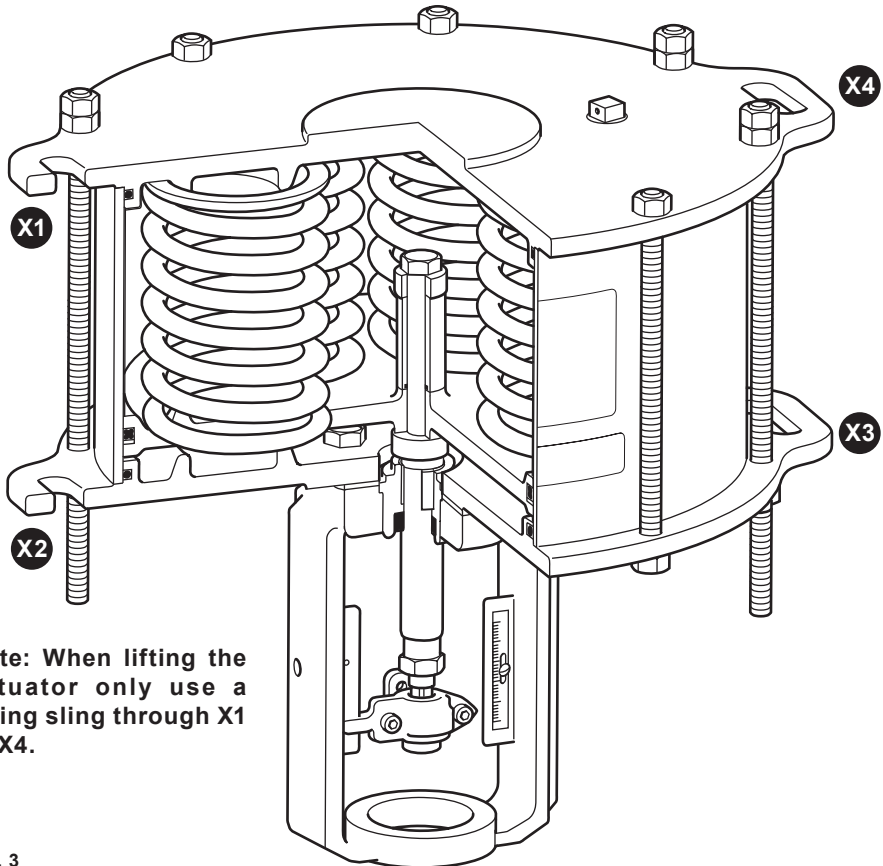

Note: When lifting the actuator only use a lifting sling through X1 to X4.

Fig. 3

3. Installation

Caution: Sling eyes (X, see Figure 3) are **not to be used** for lifting an actuated valve assembly. Sling eyes can only be used to stabilise the assembly. Suitable support of the valve and actuator will be required.

See separate Installation and Maintenance Instructions for the control valve. For details of differential pressures associated with the Spira-trol™ KE and KEA control valves refer to the relevant actuator Technical Information (TI) sheet.

The actuators should be installed in such a position as to allow full access to both the actuator and the valve for maintenance purposes. The preferred mounting position is with the actuator and valve spindle in the vertical position or horizontal to the pipework (it is essential that support is provided when the installation is in the horizontal position), see Figure 4).

Note : Due to the thrust that the actuator uses, it can deteriorate the valve or the coupling parts, if the working pressures are exceeded.

Vertically
above pipework

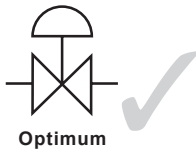

Horizontal

(it is essential that support is provided when the installation is in the horizontal position)



Vertically
below pipework



Fig. 4

3.1 Fitting the actuator (extend) to the valve

- Remove the screw and nut (**13** and **14**) then the rear and front clamp (**11** and **12**).
- Ensure the indicator scale is facing the same way as the valve name-plate.
- Apply the control signal pressure to the bottom of the actuator to bring the spindle (**19**) to the mid-travel position.
- Manually push the valve spindle down to ensure that the plug is on the valve seat.
- Screw the yoke adapter (**35**) onto the valve and tighten it to 50 Nm (36.9 lbf ft) - (TN2___E_ only).
- Put the yoke sleeve (**36**) onto the valve bonnet (TN2___EC only).
- Locate the actuator yoke onto the valve bonnet and fit the lock-nut (**A**).
- Screw the lock-nut of the valve's spindle down to the lowest part of the valve spindle.
- Screw the bottom connector (**29**) onto the valve spindle, caution there must be no valve spindle threads above the bottom connector.
- Loosen the lock-nut and screw the connector (**20**) upwards 3 turns, then remove the air supply.
- Apply the minimum signal pressure + 0.1 bar (1.45 psi) maximum to the bottom of the actuator, and then adjust the connector (**20**) so that it touches the bottom connector (**29**), then tighten the lock-nut (**15**).
- Release the control air signal. Fit the front and rear clamps (**11** and **12**).
- Fit the locking screws and nuts (**13** and **14**) loosely.
- Operate the actuator and valve over its full travel four times to ensure alignment.
- Tighten the mounting nut to 50 N m (36.9 lbf ft).

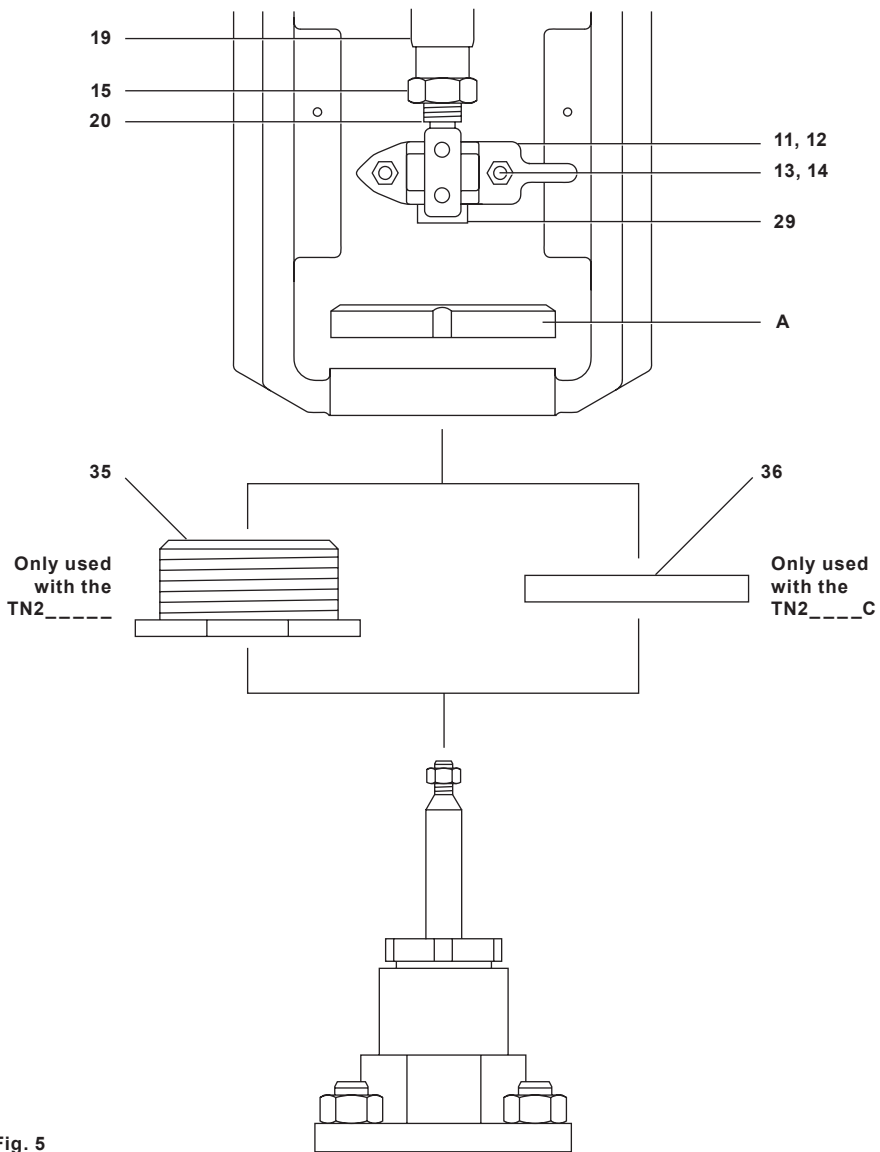

3.2 Fitting the actuator (retract) to the valve

- Remove the screw and nut (13 and 14) then the rear and front clamp (11 and 12).
- Ensure the indicator scale is facing the same way as the valve name-plate.
- Apply the control signal pressure to the top of the actuator to bring the spindle (19) to the mid-travel position.
- Manually push the valve spindle down to ensure that the plug is on the valve seat.
- Screw the yoke adapter (35) onto the valve and tighten it to 50 Nm (36.9 lbf ft) - (TN2___E_ only).
- Put the yoke sleeve (36) onto the valve bonnet (TN2___EC only).
- Locate the actuator yoke onto the valve bonnet and fit the lock-nut (A).
- Screw the lock-nut of the valve's spindle down to the lowest part of the valve spindle.
- Screw the bottom connector (29) onto the valve spindle, caution there must be no valve spindle threads above the bottom connector.
- Loosen the lock-nut and screw the connector (20) upwards 3 turns, then remove the air supply.
- Adjust the connector (20) so that it touches the bottom connector (29). Apply the minimum signal pressure + 0.1 bar (1.45 psi) maximum to the top of the actuator then unscrew the connector (20) downwards 3 turns, and finally tighten the lock-nut (15).
- Release the control air signal. Fit the front and rear clamps (11 and 12).
- Fit the locking screws and nuts (13 and 14) loosely.
- Operate the actuator and valve over its full travel four times to ensure alignment.
- Tighten the mounting nut to 50 N m (36.9 lbf ft).

The air supply to the actuator must be '**dry and free from oil**'. Contact Spirax Sarco for more details with relation to composite tube/media compatibility. For high temperature conditions, insulate the control valve and pipework only to protect the actuator.

Note: The actuator cannot be fitted onto an older style control valve.

Caution: If the complete assembly is installed horizontally then the air supply **must** be connected at the lowest point of the actuator.

Warning: The actuator cylinder must only be pressurized on the opposite side of the piston holding the spring. The housing vent cap must be left unrestricted. If the assembly is to be mounted horizontally then it is essential to provide suitable support for the actuator.

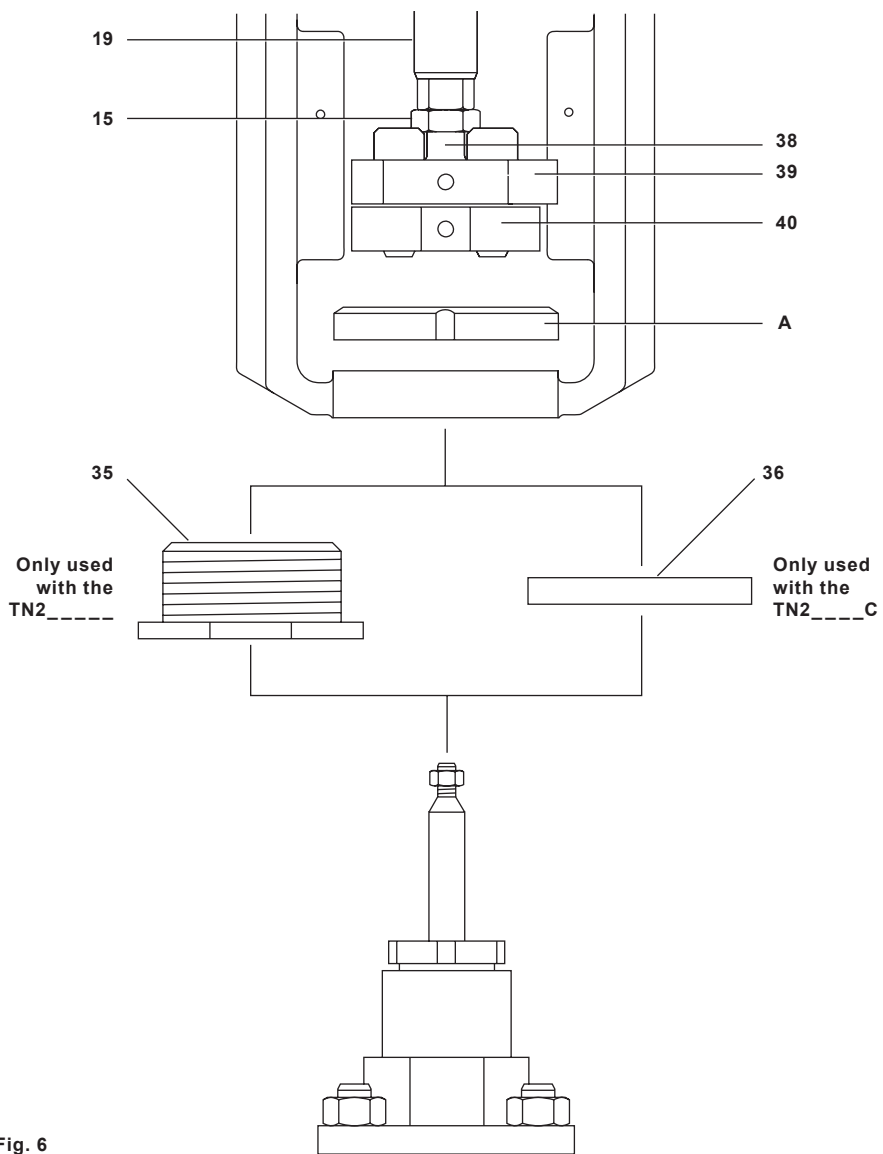

Fig. 6

4. Commissioning

Note: Before actioning any maintenance programme observe the 'Safety information' in Section 1.

Warnings:

1. **Actuator support will be required due to weight.**
2. **The actuator contains a pre-compressed spring.**
3. **Special assembly tool required.**
4. **Use POLYLUB GLY 801 (lubricating grease) only.**

The TN2000 series of pneumatic actuators are maintenance free. To ensure satisfactory operation it is strongly recommended that the control signal air is filtered and supplied dry and free of oil. Should it be necessary to replace spare parts the following procedure should be used.

4.1 Removing the actuator from the valve:

Note:

Remove the handwheel first, if fitted, by following the instructions in Sections 4.4 or 4.5.

- Remove the screws and nuts (**13**, **14**) then the rear and front clamp (**11**, **12**).
- Remove the lock-nut (**A**).
- Remove the air supply.
- Remove the actuator from the valve.

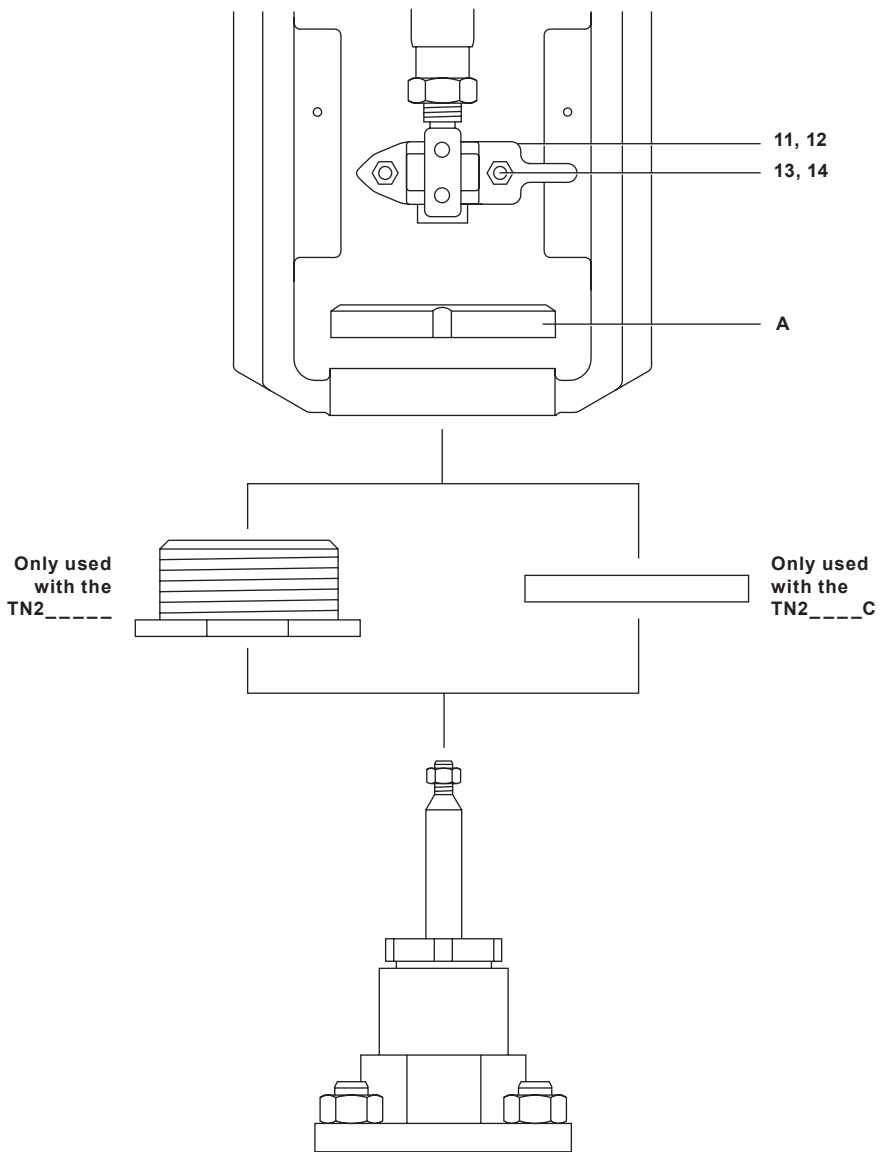

Fig. 7

4.2 Replacing the 'O' and 'X' rings (SE and DE actuators)

Note: Remove the actuator from the valve as described in Section 4.1.

Note: Depending on the actuator size there is either 3 or 4 short threaded bars which must be removed last to ensure that the spring tension is removed before taking the actuator apart.

- Depending on the actuator size loosen and remove the 3 or 4 threaded bars (7).
- Loosen then remove the remaining long securing nuts (23), see note above.
- Remove the upper cylinder end cap (4).
- Remove the spring (3) (not applicable for DA).
- Remove the cylinder (5).
- If the bearing seals are to be replaced remove the spindle (19) to fit the lower seal (17).
- Replace the 'O' and 'X' rings (6, 26 and 24).

To rebuild the actuator follow the next procedure:

Caution: POLYLUB GLY 801 must be used to ensure smooth operation of the piston.

- Replace the spindle (19) if previously removed.
- Apply grease to the internal of the cylinder (5) and the bearings (18) (approximately 50 mm to be in contact with piston).
- Lower the cylinder (5) onto the lower cylinder end cap (1).
- Replace the springs (3).
- Replace the upper cylinder end cap (4) over the springs (3).
- Depending on the actuator size refit the 3 or 4 long threaded bars (23) and tighten the nuts (8) evenly to pull the cylinder (5) onto the lower cylinder end cap. Then tighten to 30 Nm (22.1 lbf ft).
- Refit all remaining securing screws and nuts (7 and 8) and tighten to 30 Nm (22.1 lbf ft).
- Re-attach the actuator to the valve as described in Section 3.1.

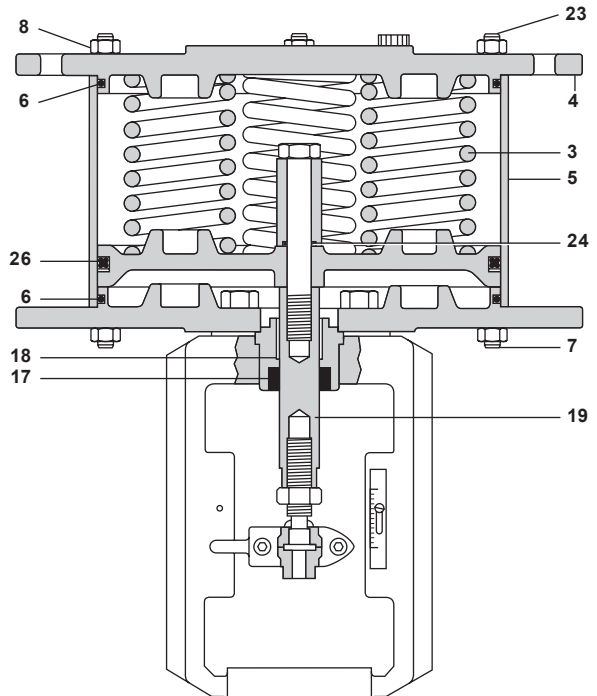

Fig. 8 TN2000E

4.3 Replacing the 'O' and 'X' rings (SR and DR actuators)

Note: Remove the actuator from the valve as described in Section 4.1

Note: There are 5 long securing nuts that must be removed last to ensure that the spring tension is removed.

- Loosen and remove the connector (20), see Figure 9.
- Depending on the actuator size loosen and remove the 3 or 4 short threaded bars (7).
- Evenly loosen and remove the remaining long securing nuts (23), see note above.
- Remove the upper cylinder cap (4).
- Remove the piston assembly (A part numbers: 2, 19, 24, 26, 31 and 32).
- Remove the cylinder (5).
- Replace the 'O' and 'X' rings (17, 6, 24 and 26).

To rebuild the actuator follow the next procedure:

Caution: POLYLUB GLY 801 must be used to ensure smooth operation of the piston.

- Apply grease to the internal of the cylinder (5) and the bearings (18) (approximately 50 mm) to be in contact with the piston).
- Lower the cylinder (5) onto the lower cylinder.
- Lower the piston assembly into the actuator (2, 19, 24, 26, 31 and 32), taking care not to damage the bearing (18) and seal (17).
- Replace the upper cylinder (4).
- Depending on the actuator size refit the 3 or 4 long threaded bars (23) evenly to pull the piston assembly into the cylinder (5) and the cylinder (5) onto the cylinder end caps (1 and 4). Then tighten to 30 Nm (22.1 lbf ft).
- Refit all remaining securing screws and nuts (7, 8 and 23) and tighten to 30 Nm (22.1 lbf ft).
- Re-attach the actuator to the valve as described in Section 3.2.

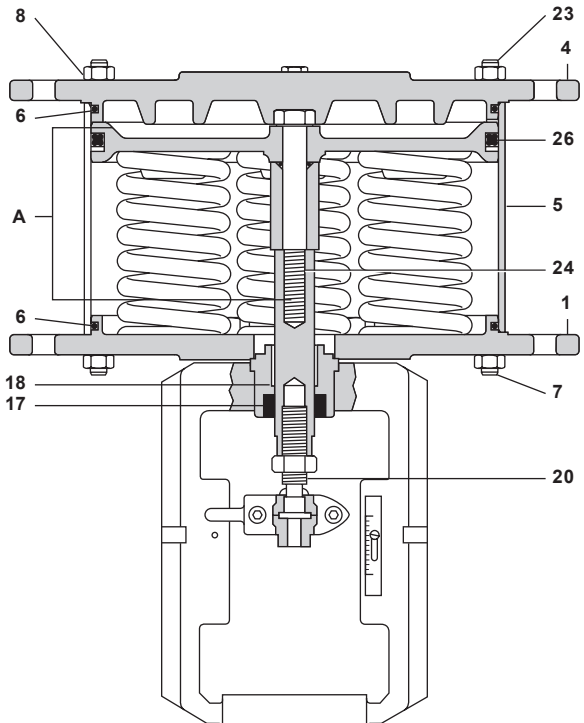

Fig. 9 TN2000R

4.4 TN203_SEH or TN203_SRH (handwheel)

Note: Ensure the handwheel has no compressive load on the actuator springs.

- Remove the plastic barrel plug (A), hold the actuator spindle at point (B) with a spanner and simultaneously loosen and remove the screw (C).
- Remove the handwheel (D), taking care not to displace the internal bearing (F).

To re-attach the handwheel, the above the procedure should be reversed ensuring the correct torques are used.

Table 1 - Recommended tightening torques

Screw (C)		Spindle connector (E)	
N m	lbf ft	N m	lbf ft
20	29.5	40	29.5

Fig. 10 TN203_SEH

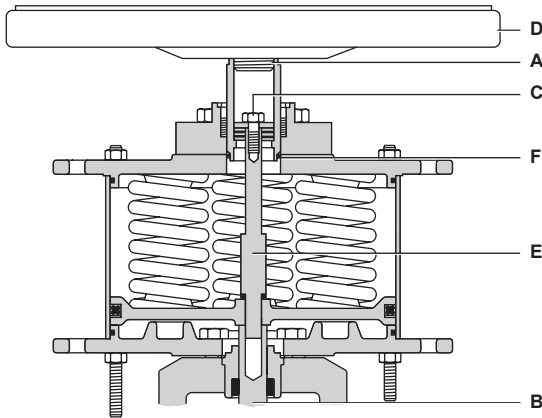
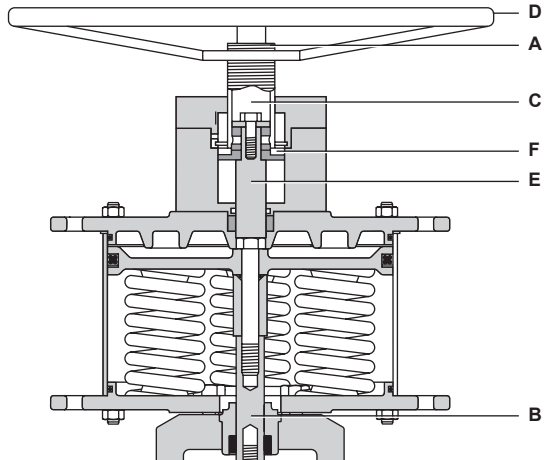

Fig. 11 TN203_SRH



4.5 TN215_SEH or SRH (handwheel)

Note: Ensure the handwheel has no comprehensive load on the actuator springs. Rotating the handwheel clockwise retracts the spindle, rotating it anti-clockwise extends the spindle. The actuator is shown in the fully extended position)

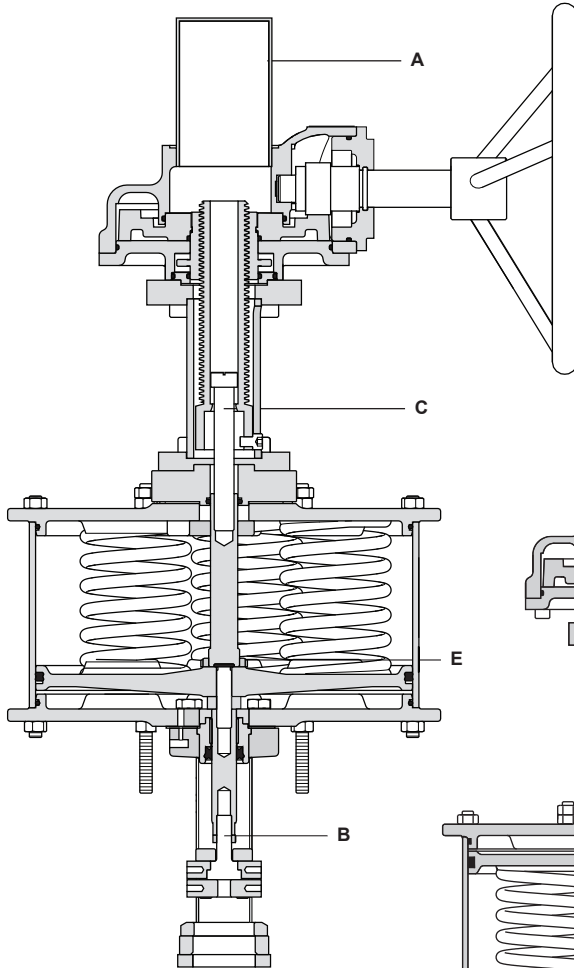

Fig. 12 TN215_ECH

- Remove the plastic cap (A), hold the actuator spindle at point (B) with a spanner and loosen the screwed insert (C), or screw (for retract).

To re-attach the handwheel, the above procedure should be reversed ensuring the correct torques are used (see Table 1).

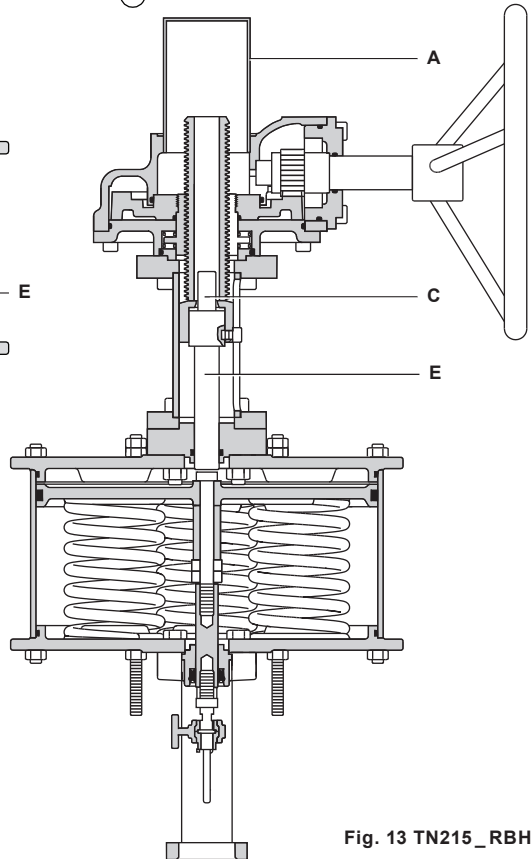

Fig. 13 TN215_RBH

5. Spare parts

The spare parts available are common across the range of actuators detailed in this document. No other parts are available as spares.

Available spares

'O' ring kit	See the Materials illustration on pages 6 and 8 for item identification	6, 17, 24 and 26
Travel indicator kit	See the Materials illustration on pages 6 and 8 for item identification	9, 21 and 34
Spring kit	See the Materials illustration on page 6 for item identification	3
Handwheel	EH kit	A
	RH kit	B

How to order spares

Always order spares by using the description given in the column headed 'Available spares' and state the actuator model.

Example:

1 - 'O' ring kit for a Spirax Sarco TN2033SEB pneumatic piston actuator.

Fig. 14 TN203_SEH

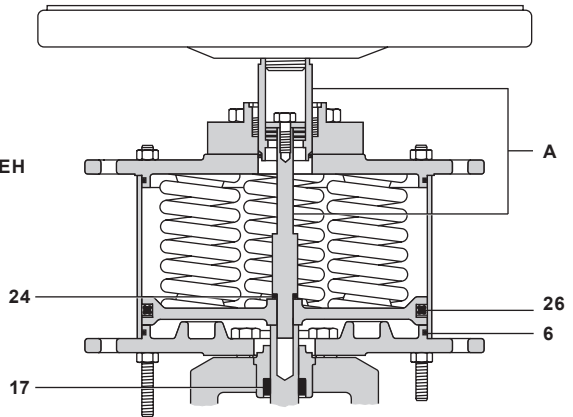
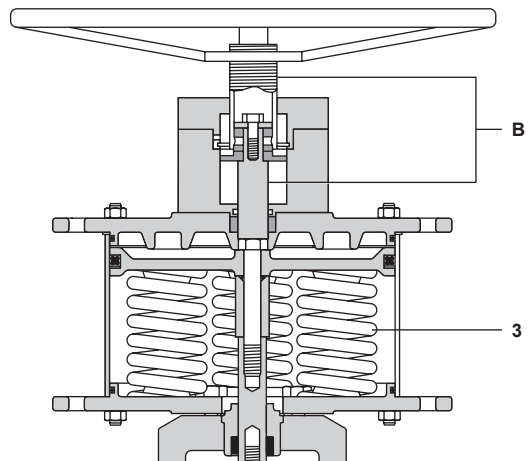

Fig. 15 TN203_SRH



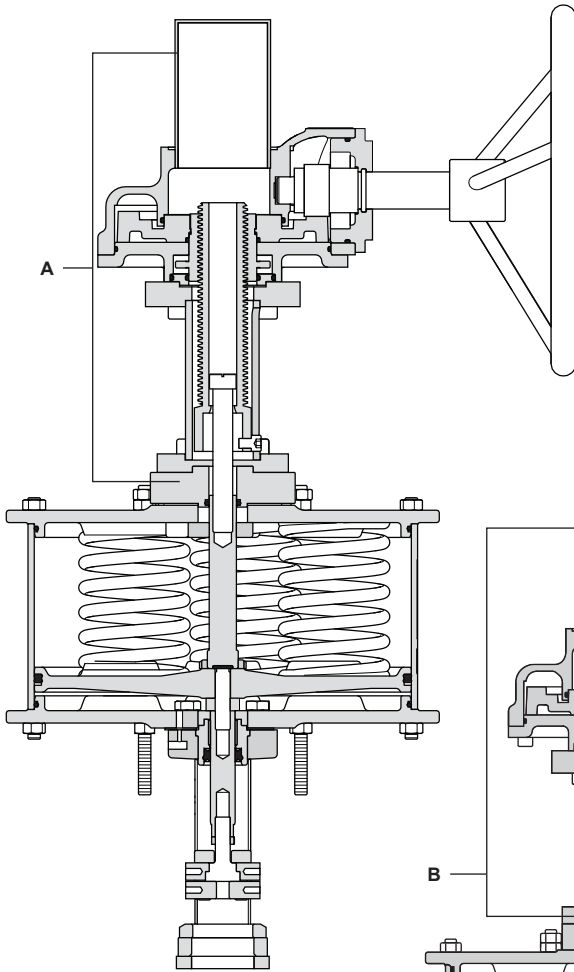

Fig. 16 TN215_ECH

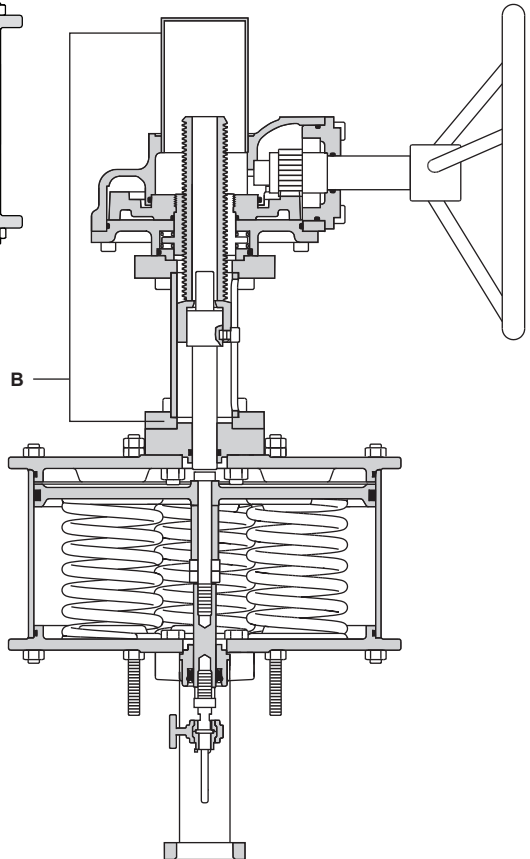

Fig. 17 TN215_RBH

