

## TN2000 Series Pneumatic Piston Actuators

### Installation and Maintenance Instructions

---

---

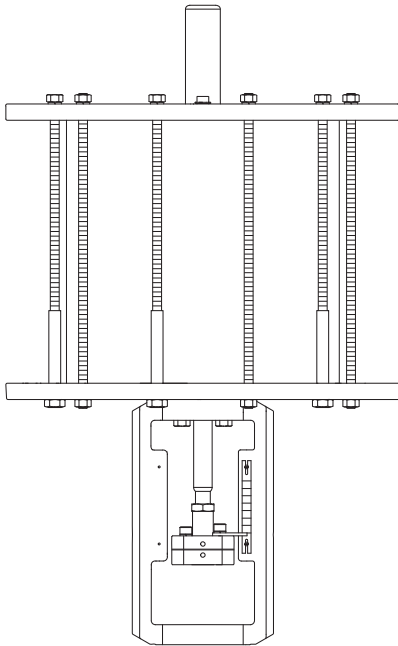

1. Safety information
2. General product information
3. Installation
4. Maintenance
5. Spare parts



# 1. Safety information

Safe operation of these products can only be guaranteed if they are properly installed, commissioned, used and maintained by qualified personnel (see Section 1.11) in compliance with the operating instructions. General installation and safety instructions for pipeline and plant construction, as well as the proper use of tools and safety equipment must also be complied with.

## 1.1 Intended use

Referring to the Installation and Maintenance Instructions, name-plate and Technical Information Sheet, check that the product is suitable for the intended use/application. Please note that this product is out of the scope of the European Pressure Equipment Directive 2014/68/EU.

- i) This product has been specifically designed for use compressed air. The products' use on other fluids may be possible but, if this is contemplated, Spirax Sarco should be contacted to confirm the suitability of the product for the application being considered.
- ii) Check material suitability, pressure and temperature and their maximum and minimum values. If the maximum operating limits of the product are lower than those of the system in which it is being fitted, or if malfunction of the product could result in a dangerous overpressure or overtemperature occurrence, ensure a safety device is included in the system to prevent such over-limit situations.
- iii) Spirax Sarco products are not intended to withstand external stresses that may be induced by any system to which they are fitted. It is the responsibility of the installer to consider these stresses and take adequate precautions to minimise them.

## 1.2 Access

Ensure safe access and if necessary a safe working platform (suitably guarded) before attempting to work on the product. Arrange suitable lifting gear if required.

## 1.3 Lighting

Ensure adequate lighting, particularly where detailed or intricate work is required.

## 1.4 Hazardous liquids or gases in the pipeline

Consider what is in the pipeline or what may have been in the pipeline at some previous time. Consider: flammable materials, substances hazardous to health, extremes of temperature.

## 1.5 Hazardous environment around the product

Consider: explosion risk areas, lack of oxygen (e.g. tanks, pits), dangerous gases, extremes of temperature, hot surfaces, fire hazard (e.g. during welding), excessive noise, moving machinery.

## 1.6 The system

Consider the effect on the complete system of the work proposed. Will any proposed action (e.g. closing isolation valves, electrical isolation) put any other part of the system or any personnel at risk? Dangers might include isolation of vents or protective devices or the rendering ineffective of controls or alarms. Ensure isolation valves are opened and closed progressively to avoid system shocks.

## 1.7 Pressure systems

Ensure that any pressure is isolated and safely vented to atmospheric pressure. Consider double isolation (double block and bleed) and the locking or labelling of closed valves. Do not assume that the system has depressurised even when the pressure gauge indicates zero.

## 1.8 Temperature

Allow time for temperature to normalise after isolation to avoid the danger of burns.

## 1.9 Tools and consumables

Before starting work ensure that you have suitable tools and/or consumables available. Use only genuine Spirax Sarco replacement parts.

## 1.10 Protective clothing

Consider whether you and/or others in the vicinity require any protective clothing to protect against the hazards of, for example, chemicals, high /low temperature, radiation, noise, falling objects, and dangers to eyes and face.

## 1.11 Permits to work

All work must be carried out or be supervised by a suitably competent person. Installation and operating personnel should be trained in the correct use of the product according to the Installation and Maintenance Instructions.

Where a formal 'permit to work' system is in force it must be complied with. Where there is no such system, it is recommended that a responsible person should know what work is going on and, where necessary, arrange to have an assistant whose primary responsibility is safety.

Post 'warning notices' if necessary.

## 1.12 Handling

Manual handling of large and/or heavy products may present a risk of injury. Lifting, pushing, pulling, carrying or supporting a load by bodily force can cause injury particularly to the back. You are advised to assess the risks taking into account the task, the individual, the load and the working environment and use the appropriate handling method depending on the circumstances of the work being done.

## 1.13 Residual hazards

In some cases the product is provided with pre-compressed springs. Any operation to open the spring housing is to be carried out strictly following the correct procedure as detailed in this document.

## 1.14 Freezing

Provision must be made to protect products which are not self-draining against frost damage in environments where they may be exposed to temperatures below freezing point.

## 1.15 Disposal

This product should not be dismantled without first releasing the compression on the spring (if fitted). This product is recyclable and no ecological hazard is anticipated with its disposal providing due care is taken, however the following list of exception will require individual disposal in line with local health and safety regulations:

- PTFE
- Polythene
- PVC
- Composite tube
- Fluorocarbon 'O' rings.

**Warning: 'O' rings must not be incinerated, as hydrofluoric acid will be formed.**

Please visit the Spirax Sarco product compliance web pages

<https://www.spiraxsarco.com/product-compliance>

for up to date information on any substances of concern that may be contained within this product. Where no additional information is provided on the Spirax Sarco product compliance web page, this product may be safely recycled and/or disposed providing due care is taken. Always check your local recycling and disposal regulations.

## 1.16 Returning products

Customers and stockists are reminded that under EC Health, Safety and Environment Law, when returning products to Spirax Sarco they must provide information on any hazards and the precautions to be taken due to contamination residues or mechanical damage which may present a health, safety or environmental risk. This information must be provided in writing including Health and Safety data sheets relating to any substances identified as hazardous or potentially hazardous.

## 2. General product information

### 2.1 Description

TN2000 series pneumatic piston actuators are suitable for use with DN125 to DN200 Spira-trol™ control valves of which three versions are available; Single acting (with spring), Double acting (with spring) and Double acting (no spring). The availability of these three versions meets the requirements of valves at various differential pressures and in a variety of applications.

### 2.2 Technical data

Temperature range	-15 °C to +110 °C
Maximum operating inlet pressure	10 bar g
Air supply connection	3/8" NPT
Actuator travel	70 mm

### 2.3 Materials

No.	Part	Material
1	Yoke	SG iron
2	Lower cylinder end cap	SG iron BS EN 1563 GJS 400 18U-LT
3	Upper cylinder end cap	SG iron BS EN 1563 GJS 400 18U-LT
4	Cylinder	Composite tube
5	Piston	SG iron
6	Spring	Chrome vanadium steel
7	Spindle	Stainless steel
8	Spindle sleeve	Carbon steel (plated)
9	Lock-nut	M27 Carbon steel (plated)
10	Bearing and seal insert	Carbon steel (plated)
11	Indicator plate	Stainless steel
12	Top connector	Carbon steel (plated)
13	Bottom connector	Carbon steel (plated)
14	Connector	Stainless steel
15	Rod seal wiper	Polyurethane
16	DU plain bearing	PTFE/steel composite

Part numbers 17 to 33 shown on page 8

**Note: When lifting the actuator only use a lifting sling through X1 to X4.**

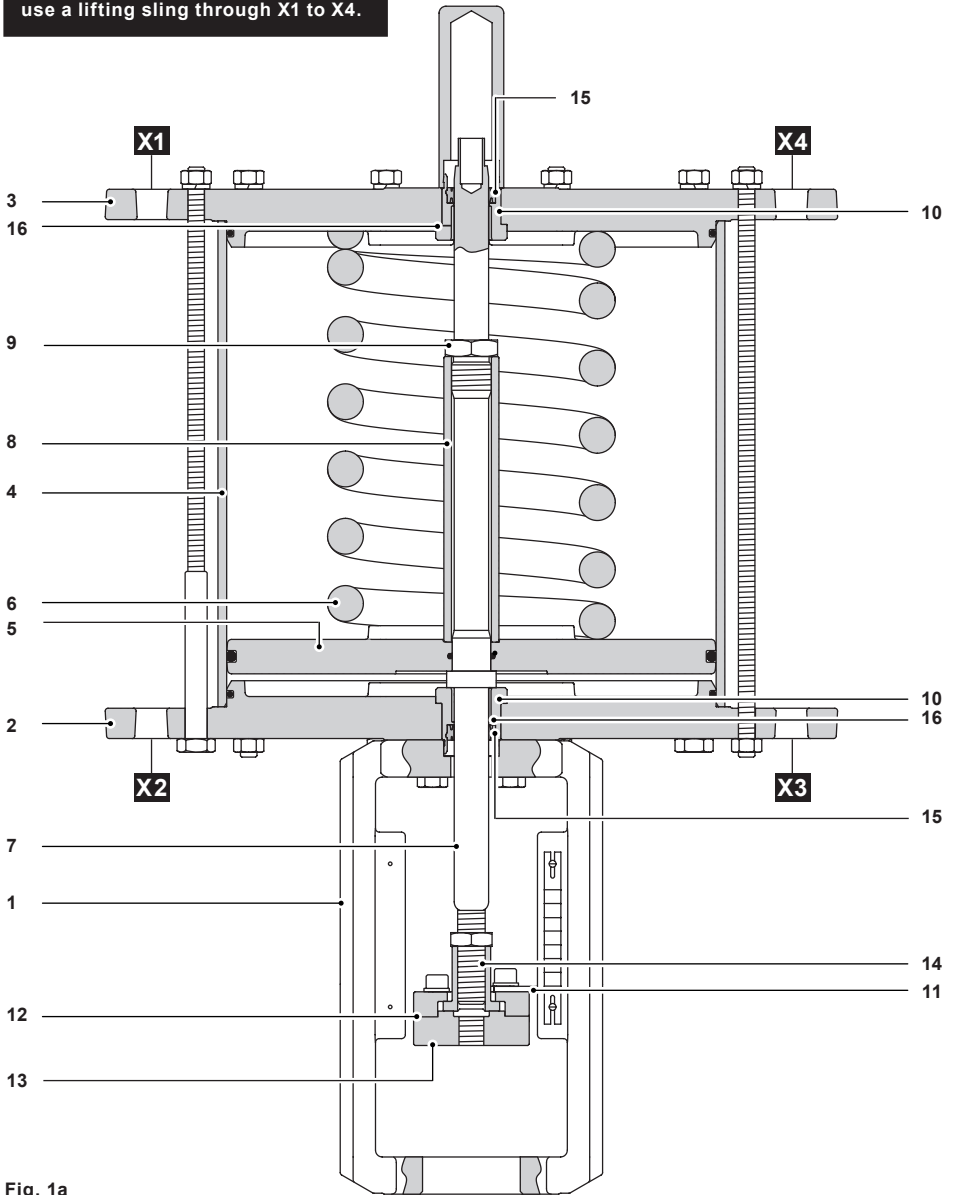

Fig. 1a

## 2.3 Materials (continued)

No.	Part		Material
17	Long nut		Carbon steel (plated)
18	Nut and threaded bar		Carbon steel (plated)
19	Threaded bar	M12	Carbon steel (plated)
20	3/8" NPT vent plug (not shown)		LD Polyethylene
21	Cover		PVC
22	Scale		Stainless steel
23	Nut	M12	Carbon steel (plated)
24	Lock-nut	M20	Stainless steel
25	Cap screw		Carbon steel (plated)
26	Bolt	M12	Stainless steel
27	Pan head screw		Carbon steel (plated)
28	Nut	M2.5	Carbon steel (plated)
29	'O' ring		Fluorocarbon rubber (Viton)
30	'O' ring		Fluorocarbon rubber (Viton)
31	'O' ring		Fluorocarbon rubber (Viton)
32	Spring washer	M12	Carbon steel (plated)
33	Spring washer	M10	Carbon steel (plated)



**Note: When lifting the actuator only use a lifting sling through X1 to X4.**

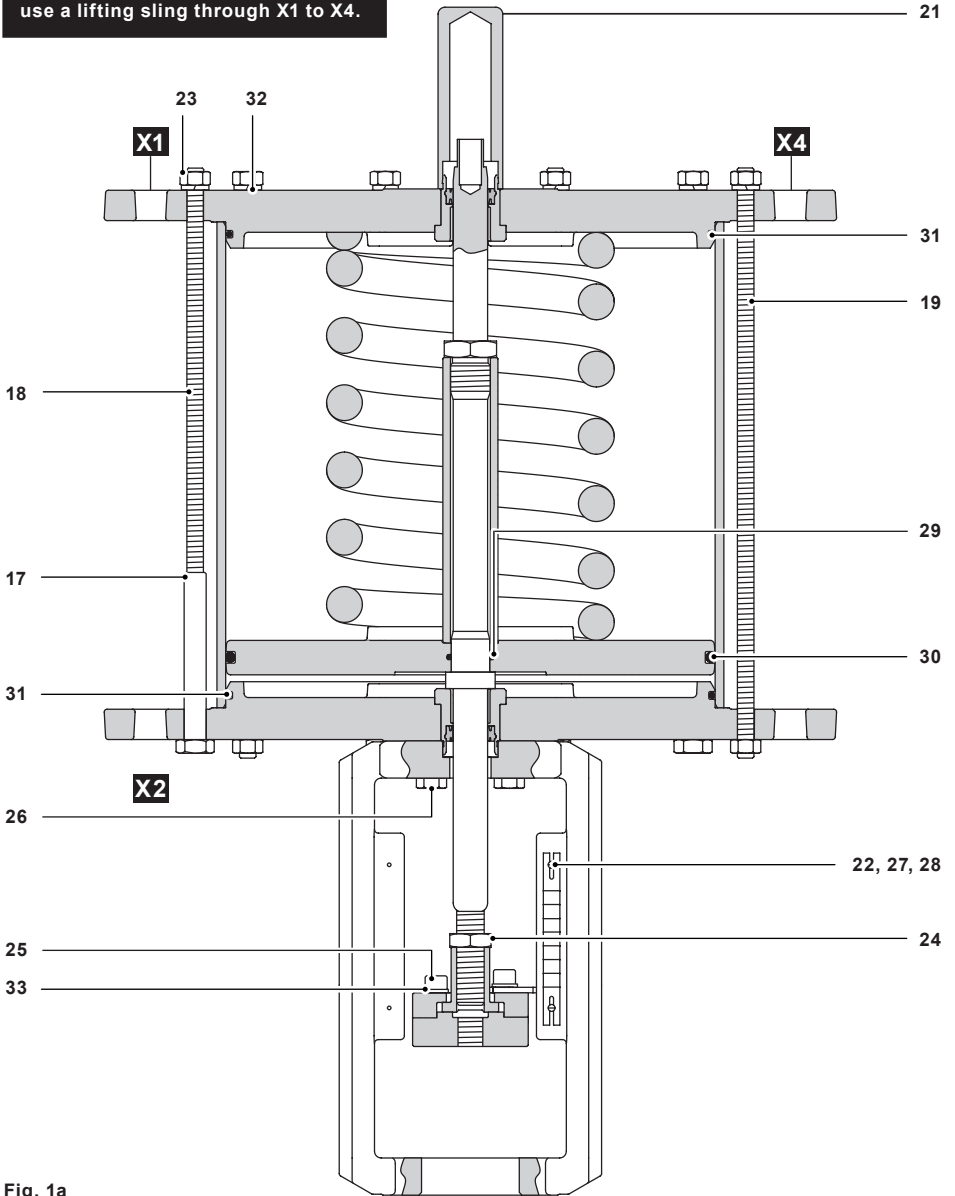

Fig. 1a

# 3. Installation

**Caution:** Sling eyes (X, see Figure 2) are **not to be used** for lifting an actuated valve assembly. Sling eyes can only be used to stabilise the assembly. Suitable support of the valve and actuator will be required.

See separate Installation and Maintenance Instructions for the control valve. For details of differential pressures associated with the Spira-trol™ KE and KEA control valves refer to the relevant actuator Technical Information (TI) sheet.

The actuators should be installed in such a position as to allow full access to both the actuator and the valve for maintenance purposes. The preferred mounting position is with the actuator and valve spindle in the vertical position or horizontal to the pipework (it is essential that support is provided when the installation is in the horizontal position), see Figure 2).

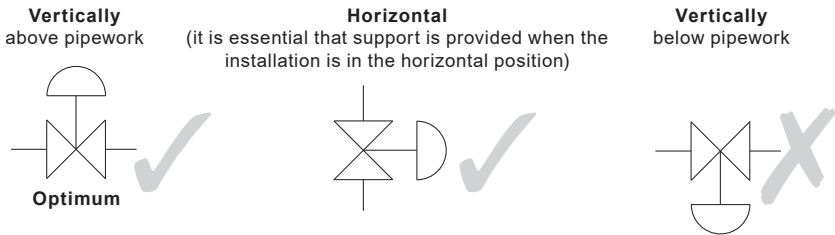

Fig. 2

The air supply to the actuator must be '**dry and free from oil**'. Contact Spirax Sarco for more details with relation to composite tube/media compatibility. For high temperature conditions, insulate the control valve and pipework only to protect the actuator.

### Note

The actuator cannot be fitted onto an older style control valve.

### Caution

If the complete assembly is installed horizontally then the air supply **must** be connected at the lowest point of the actuator.

### Warning

The actuator cylinder must only be pressurized on the opposite side of the piston holding the spring. The housing vent cap must be left unrestricted. If the assembly is to be mounted horizontally then it is essential to provide suitable support for the actuator.

### 3.1 Fitting the TN2000 SE, DE and DA actuators to the valve

- Remove the bottom connector (13).
- Ensure that the indicator scale (22) is facing the same way as the valve name-plate.
- Apply the control signal pressure to the bottom of the actuator to bring the spindle (7) to the mid-travel position.
- Manually push the valve spindle down to ensure that the valve plug is on the valve seat.
- Locate the actuator yoke on the valve bonnet and fit the securing screws (A) to a torque of 40 Nm.
- Screw the lock-nut (B) down to the lowest part of the valve spindle.

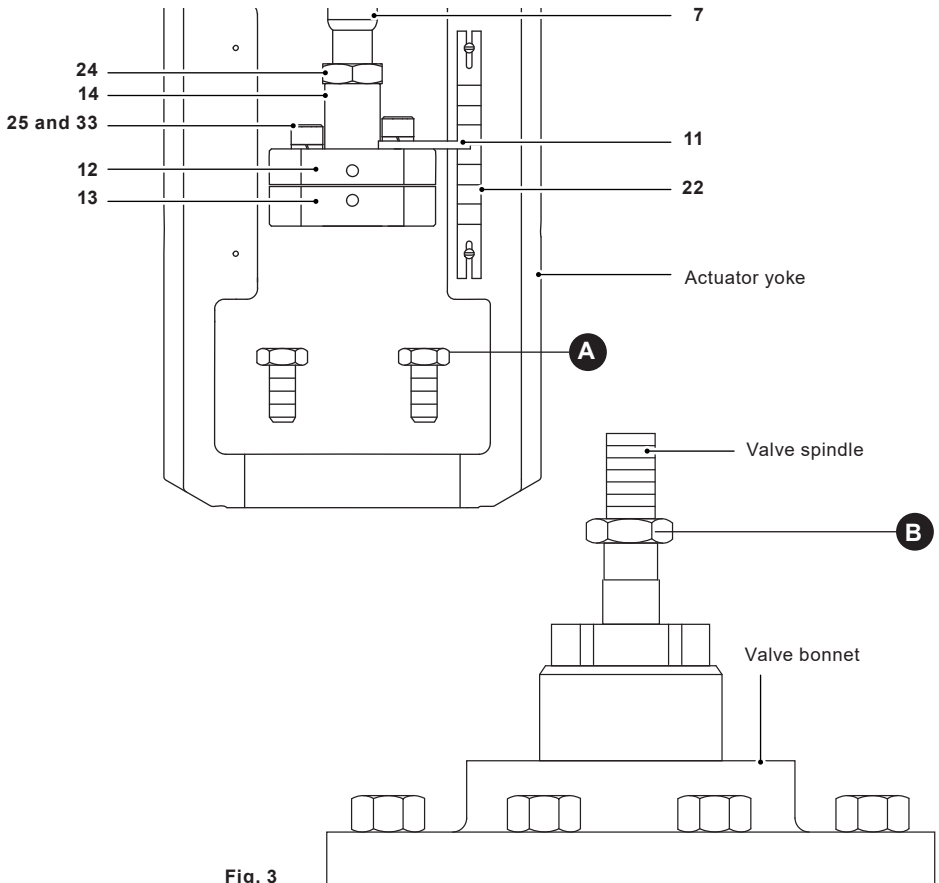

Fig. 3

- Screw the bottom connector (13) onto the valve spindle, **caution** there must be no valve spindle threads above the bottom connector.
- Loosen the lock-nut (24) and screw the connector (14) upwards 3 turns, then remove the air supply.
- Adjust the connector (14) until it is touching the bottom connector (12 and 13).
- Re apply air to the actuator (to lift the actuator spindle (7)), screw the connector (14) down by 180 °.
- Remove the air supply allowing the connectors to touch (this provides a pre-load on the valve seat).
- Fit the cap screws (25), spring washers (33) and indicator plate (11) and tighten to 40 Nm.
- Raise the spindle (7) to its mid travel position.
- Tighten the spindle lock-nut (B) to 40 Nm.
- Tighten the lock-nut (24) to 40 Nm.

### 3.2 Fitting the TN2000 SR or DR actuator to the valve:

- Remove the bottom connector (13).
- Manually push the valve spindle down to ensure the valve plug is on the valve seat.
- Ensure that the indicator scale (22) is facing the same way as the valve name-plate.
- Locate the actuator yoke on the valve bonnet and fit securing screws (A) to a torque of 40 Nm.
- Screw the lock-nut (B) down to the lowest point of the valve spindle.
- Screw the connector (13) onto the valve spindle, **caution** there must be no valve spindle threads above the connector.
- Loosen the lock-nut (24) and screw the connector (14) upwards until the bottom is level with the spindle, then apply air pressure onto the top of the actuator.
- With the actuator fully extended, adjust the connector (14) until it touches the bottom connectors.
- Reduce the air supply to the actuator (to lift the actuator stem), screw the connector (14) down by 180 °.
- Re apply air to enable the connectors to touch again, fit and tighten the cap screws (25), spring washers (33) and indicator plate (11) to 40 Nm.
- Reduce air pressure and tighten lock-nut (24) to 40 Nm.
- Tighten the spindle lock-nut (B) to 40 Nm.

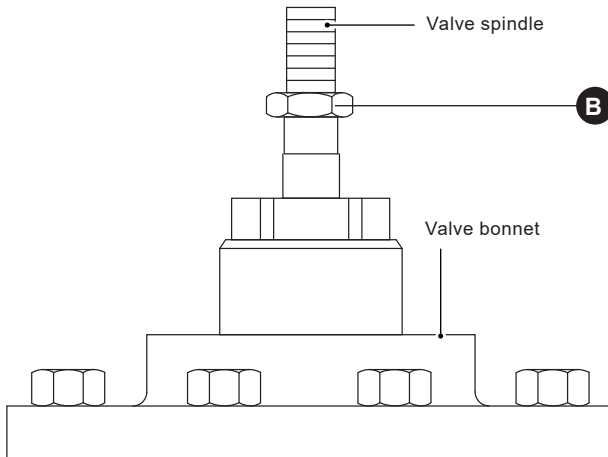
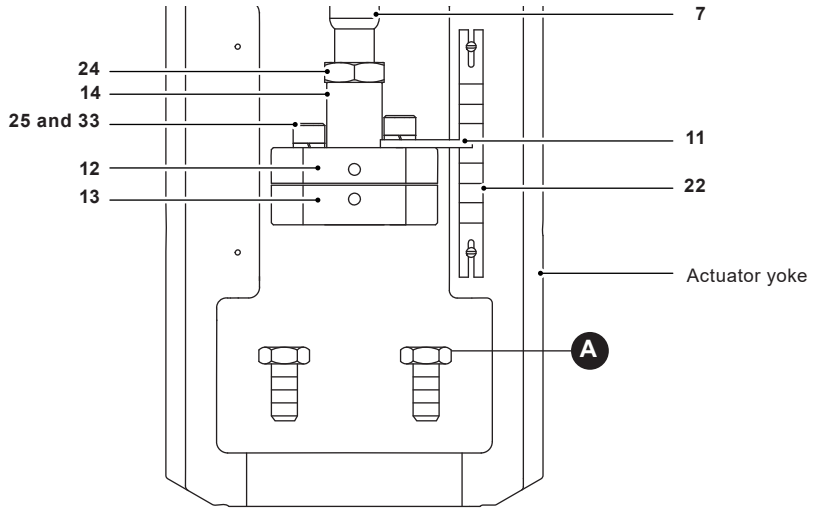

Fig. 3

## 4. Maintenance

**Note:** Before actioning any maintenance programme observe the 'Safety information' in Section 1.

### Warnings:

1. Actuator support will be required due to weight.
2. The actuator contains a pre-compressed spring.
3. Special assembly tool required.
4. POLYLUB GLY 801 (lubricating grease) only.

TN2000 series pneumatic actuators are maintenance free. To ensure satisfactory operation it is strongly recommended that the control signal air is filtered and supplied dry and free of oil. Should it be necessary to replace spare parts the following procedure should be used.

### 4.1 Removing the actuator from the valve:

**Note:** Remove the handwheel first, If fitted, by following the instructions in Sections 4.6 or 4.7.

- Apply air supply to the drive actuator to move it to its mid-travel position.
- Loosen the lock-nut **B** and remove the bottom connector (13).
- Loosen and then remove the cap screws and spring washers (25 and 33). **Note:** The valve stem and the bottom connector will move down until the valve head is on the seat.
- Remove the bottom connector (13).
- Remove the air supply.
- Loosen and then remove the securing screws **A**.
- Remove the actuator from the valve.

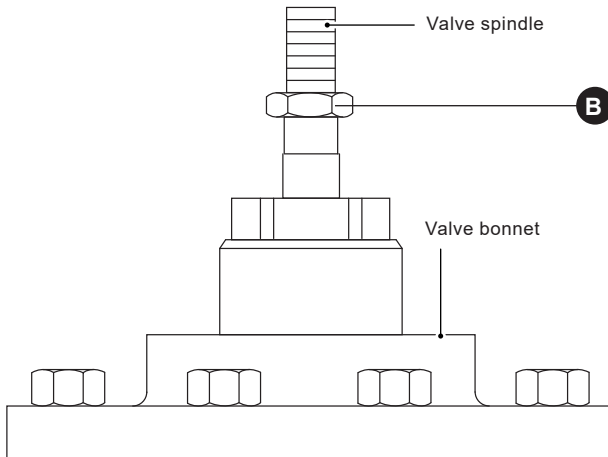
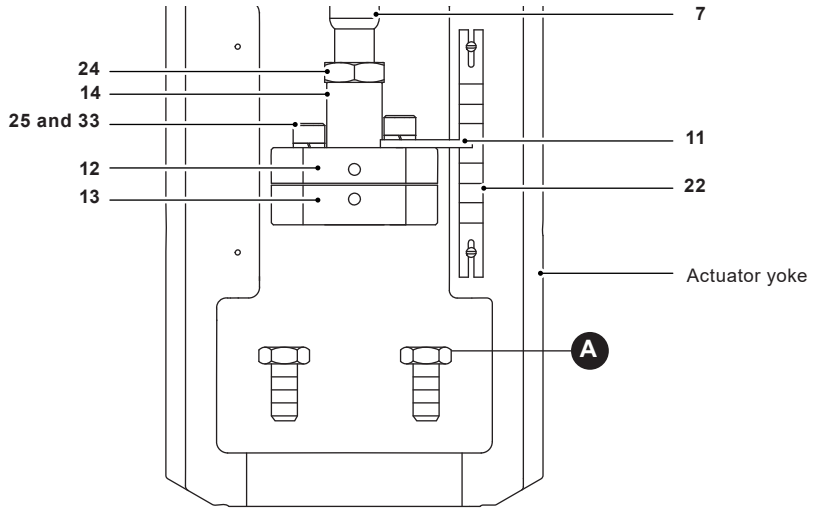

Fig. 4

## 4.2 Replacing the 'O' rings (SE and DE actuators)

**Note:** Remove the actuator from the valve as described in Section 4.1.

**Note:** There are 5 long securing nuts that must be removed last to ensure that the spring tension is removed.

- Loosen and remove the 5 securing nuts and washers (23 and 32) on the threaded bar (19).
- Loosen then remove the remaining long securing nuts (17), see note above.
- Remove the upper cylinder end cap (3), taking care not to damage the bearing (16) and seal (15).
- Remove the spring (6) (not applicable for DA).
- Remove the cylinder (4).
- If the bearing seals are to be replaced remove the spindle (7) to fit the lower seal (15).
- Replace the 'O' rings (29, 30 and 31).

### To rebuild the actuator follow the next procedure:

**Caution:** POLYLUB GLY 801 must be used to ensure smooth operation of the piston.

- Replace the spindle (7) if previously removed.
- Apply grease to the internal of the cylinder (4) and the bearings (10) (approximately 100 mm to be in contact with piston).
- Lower the cylinder (4) onto the lower cylinder end cap (2).
- Fit guiding tool over the end of the spindle.
- Replace the spring (6).
- Replace the upper cylinder end cap (3) over the guiding tool, taking care not to damage the bearing (16) and seal (15).
- Fit the 5 long securing nuts (17) onto the threaded bar (18) making sure that the spring washer (32) is in place and tighten the nuts (23) evenly to pull the cylinder (4) onto the lower cylinder end cap. Then tighten to 30 Nm.
- Fit all remaining securing screws, washers and nuts (19, 23, 32) and tighten to 30 Nm.
- Re-attach the actuator to the valve as described in Section 3.1.



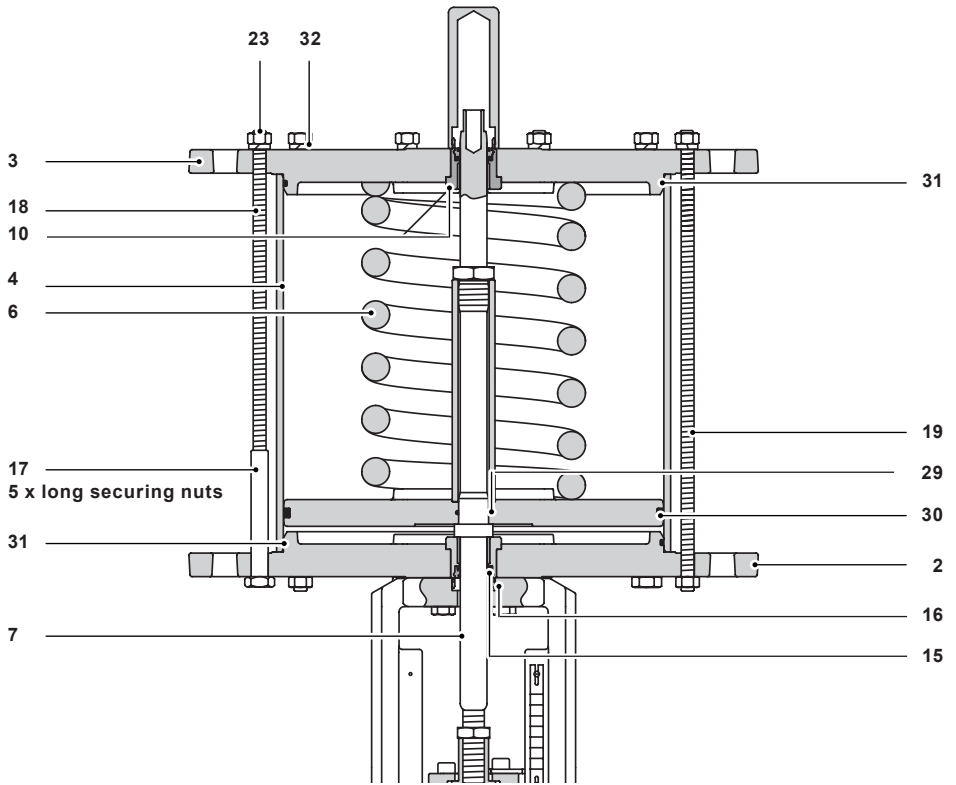

Fig. 5 TN2000E

## 4.3 Replacing the 'O' rings (SR and DR actuators)

**Note:** Remove the actuator from the valve as described in Section 4.1

**Note:** There are 5 long securing nuts that must be removed last to ensure that the spring tension is removed.

- Loosen and remove the connector (14), see Figure 4.
- Loosen and remove the 5 securing nuts and washers (23 and 32) on the threaded bar (19)
- Evenly loosen and remove the remaining long securing nuts (17), see note above.
- Remove the upper cylinder end cap (3), taking care not to damage the bearing (16) and seal (15).
- Remove the piston assembly (5, 7, 8 and 9).
- Remove the cylinder (4).
- Replace the 'O' rings (30 and 31).

### To rebuild the actuator follow the next procedure:

**Caution:** POLYLUB GLY 801 must be used to ensure smooth operation of the piston.

- Apply grease to the internal of the cylinder (4) and the bearings (10) (approximately 100 mm to be in contact with the piston).
- Lower the cylinder (4) onto the lower cylinder end cap (2).
- Lower the piston assembly into the actuator (5, 7, 8 and 9), taking care not to damage the bearing (16) and seal (15).
- Replace the upper cylinder end cap (3), taking care not to damage the bearing (16) and seal (15).
- Fit the long 5 securing nuts (17) onto the threaded bar (18) making sure that the spring washer (32) is in place and tighten the nuts (23) evenly to pull the piston assembly into the cylinder (4) and the cylinder (4) onto the cylinder end caps (2 and 3). Then tighten to 30 Nm.
- Fit all the remaining securing screws, washers and nuts (19, 32 and 23) and tighten to 30 Nm.
- Re-attach the actuator to the valve as described in Section 3.2.

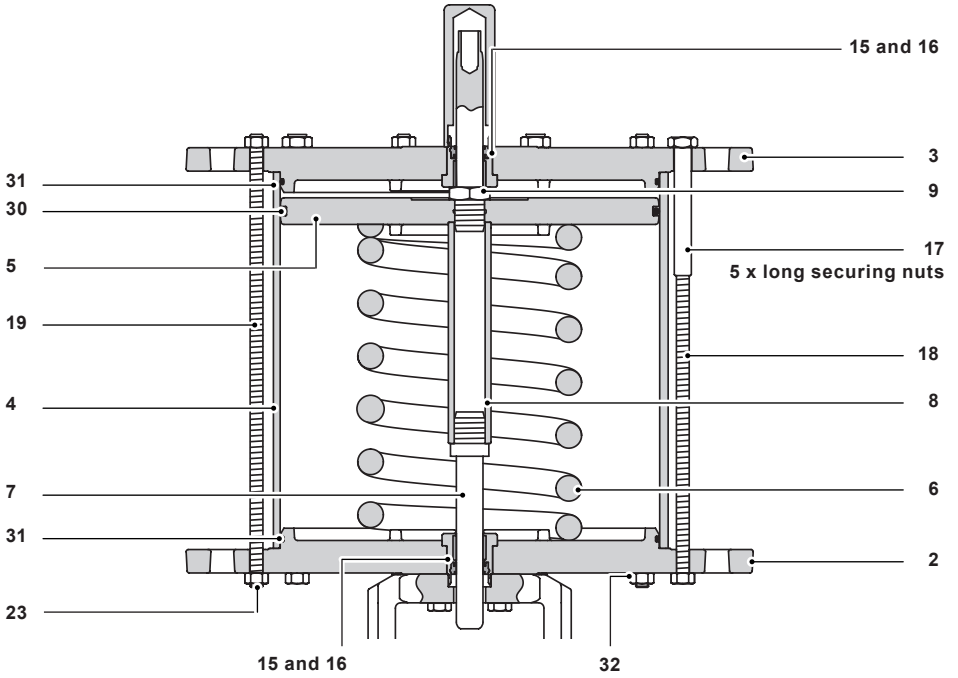

Fig. 6 TN2000R

## 4.4 Conversion of a TN2000E to a TN2000R actuator

**Warning:** It is not recommended to reverse this actuators operation outside of a controlled area. Lifting equipment will be required.

**Note 1:** Remove the actuator from the valve as described in Section 4.1.

**Note 2:** If a handwheel is fitted, a new adaptor kit will be required.

**Note 3:** There are 5 long securing nuts that must be removed last to ensure that the spring tension is removed.

**Note 4:** A new product label will be required and fitted over the existing label if a conversion has been done.

Contact Spirax Sarco with the new product details, and a new label can be supplied. As a temporary measure amend the existing label with a permanent marker stating failure mode and suffix lettering (E or R).

### Dismantle:

- Loosen and remove the connector and lock-nut (14 and 24).
- Loosen and remove the 5 securing nuts and washers (23 and 32) on the threaded bar (19).
- Evenly loosen and remove the remaining long securing nuts (17), see note 3 above.
- Remove the upper cylinder end cap (3), taking care not to damage the bearing (16) and seal (15).
- Remove the spring (6).
- Remove the cylinder (4).
- 
- Using a spanner hold the upper part of the spindle **C** and remove the lock-nut (9).
- Remove the spindle sleeve (8).
- Cover the thread on the main spindle under lock-nut (9).
- Remove the piston (5).
- Remove the spindle (7), taking care not to damage the bearing (16) and seal (15).

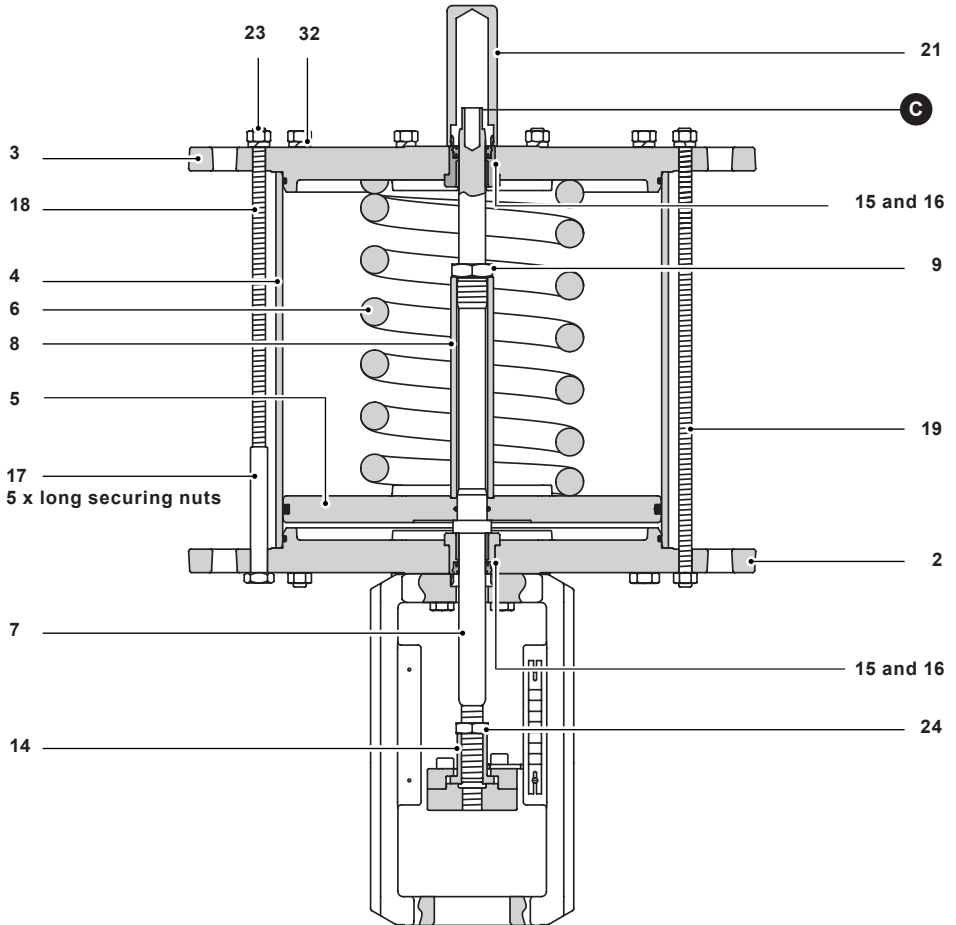

Fig. 7 TN2000E

## Reassembly:

- Fit the spring (6).
- Apply grease to the internal of the cylinder (4) (approximately 100 mm to be in contact with piston).
- Lower the cylinder (4) onto the lower cylinder end cap (2).
- Assemble the piston and the spindle assembly (5, 7, 8 and 9):
  - Fit the spindle sleeve (8) to the spindle (7).
  - Fit the protective cover to threads on the spindle for the lock-nut (9).
  - Fit the piston (5) to the spindle (7), ensure the spring location lugs are facing the spindle sleeve (8).
  - Remove the protective cover from the threads.
  - Apply low strength nutlock to the lock-nut threads on spindle (7).
  - Replace the lock-nut (9) and tighten to 100 Nm.
- Lower the piston assembly (5, 7, 8 and 9) into the actuator, taking care not to damage the bearing (16) and seal (15).
- Replace the upper cylinder end cap (3), taking care not to damage the bearing (16) and seal (15).
- Fit the 5 long securing nuts (17) onto the threaded bar (18) making sure that the spring washer (32) is in place and tighten the nuts (23) evenly to pull the piston assembly into the cylinder (4), and the cylinder (4) onto the cylinder end caps (2 and 3). Then tighten to 30 Nm.
- Fit the remaining securing screws, nuts and washers (19, 23 and 32) and tighten to 30 Nm.
- Re-attach the actuator to the valve as described in Section 3.2.

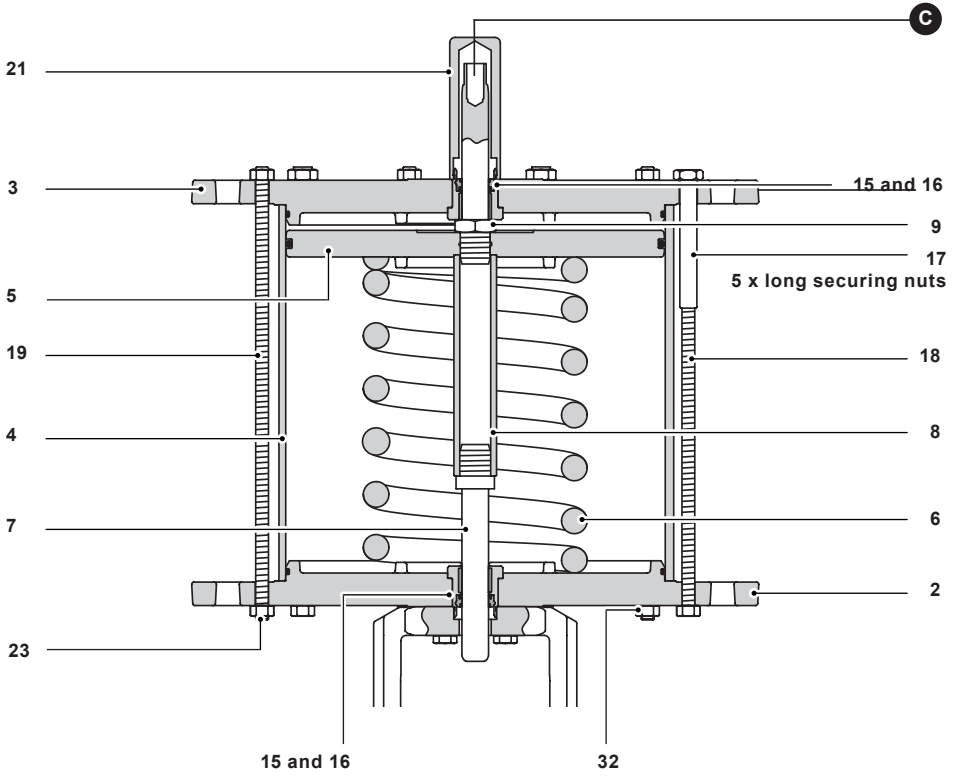

Fig. 8 TN2000R

## 4.5 Conversion of a TN2000R to a TN2000E

**Warning:** It is not recommended to reverse this actuators operation outside of a controlled area. Lifting equipment will be required.

**Note 1:** Remove the actuator from the valve as described in Section 4.1.

**Note 2:** If a handwheel is fitted, a new adaptor kit will be required.

**Note 3:** There are 5 long securing nuts that must be removed last to ensure that the spring tension is removed.

**Note 4:** A new product label will be required and fitted over the existing label if a conversion has been done.

Contact Spirax Sarco with the new product details, and a new label can be supplied. As a temporary measure amend the existing label with a permanent marker stating failure mode and suffix lettering (E or R).

### Dismantle:

- Loosen and remove the connector and lock-nut (**14** and **24**).
- Loosen and remove the 5 securing nuts and washers (**23** and **32**) on the threaded bar (**19**).
- Evenly loosen and remove the remaining long securing nuts (**17**), see note 3 above.
- Remove the upper cylinder end cap (**3**), taking care not to damage the bearing (**16**) and seal (**15**).
- Remove piston assembly (**5**, **7**, **8** and **9**), taking care not to damage the bearing (**16**) and seal (**15**).
- Remove the cylinder (**4**).
- Remove the spring (**6**).
- Using a spanner hold the upper spindle **C** and remove the lock-nut (**9**) from the piston assembly.
- Cover the thread on the main spindle under lock-nut (**9**).
- Remove the piston (**5**).
- Remove the spindle sleeve (**8**).



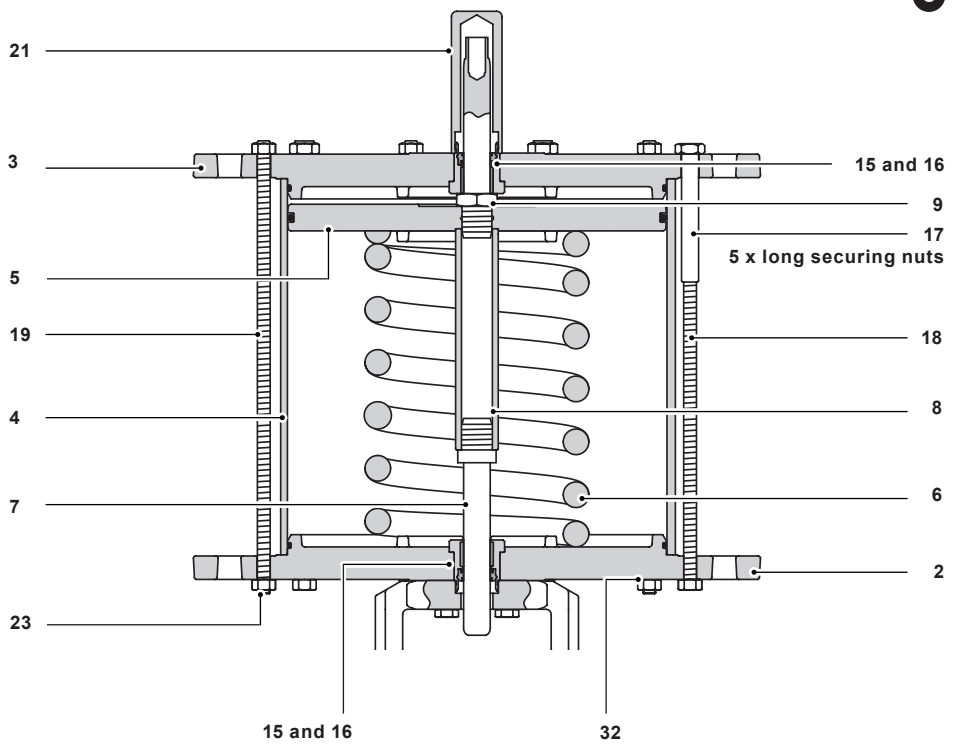

Fig. 9 TN2000R

## Reassembly:

- Assemble the piston and spindle assembly
  - Fit protective cover to the threads on the spindle for lock-nut (9)
  - Fit the piston (5) to the spindle (7), ensure the spring location lugs are facing the lock-nut (9) end.
  - Fit the spindle sleeve (8) to the spindle (7).
  - Remove protective cover from the threads.
  - Apply low strength nutlock to lock-nut threads on spindle (7)
  - Replace the lock-nut (9) and tighten to 100 Nm.
- Lower the piston assembly into the actuator (5, 7, 8 and 9), taking care not to damage the bearing (16) and the seal (15).
- Fit the spring (6).
- Apply grease to the internal of the cylinder (4) (approximately 100 mm to be in contact with piston).
- Lower the cylinder (4) onto the piston (5).
- Replace the upper cylinder end cap (3), taking care not to damage the bearing (16) and seal (15).
- Fit the 5 long securing nuts (17) onto the threaded bar (18) making sure that the spring washer (32) is in place and tighten the nuts (23) evenly to pull the cylinder (4) onto the piston (5), and the cylinder (4) onto the cylinder end caps (2 and 3). Then tighten to 30 Nm.
- Fit the remaining securing screws, nuts and washers (19, 23 and 32) and tighten to 30 Nm.
- Re-attach the actuator to the valve as described in Section 3.1.

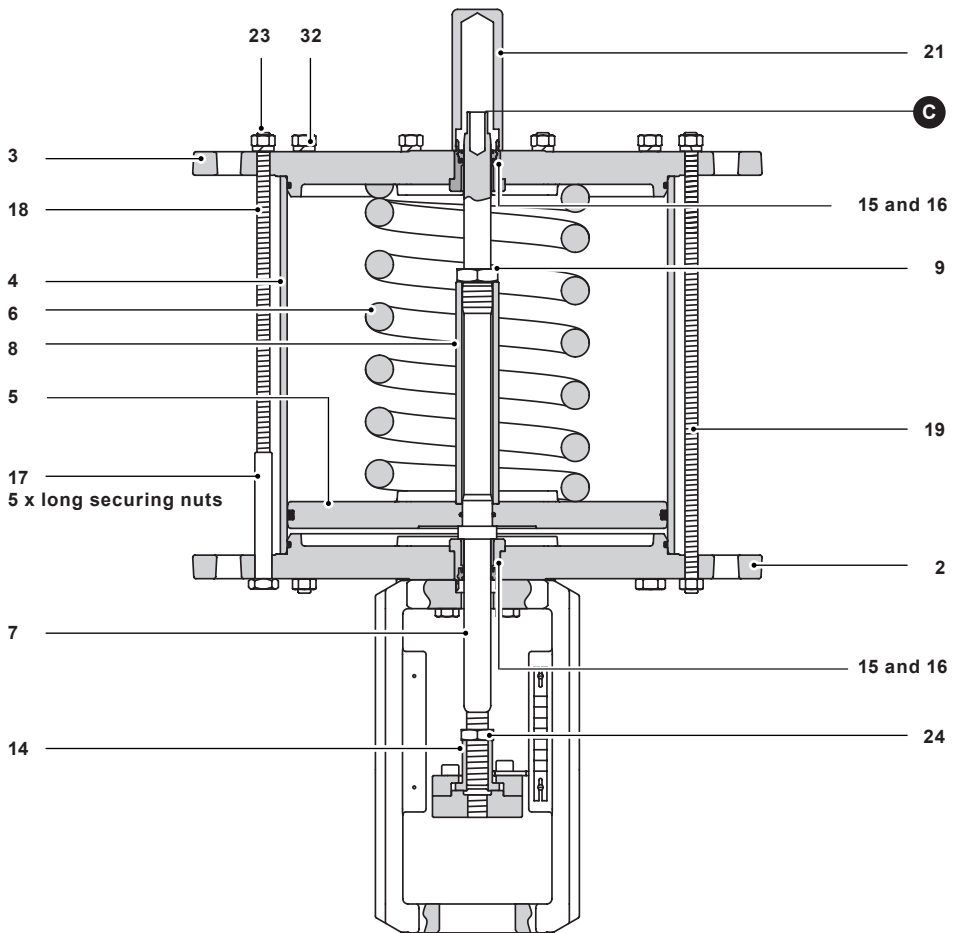

Fig. 10 TN2000E

TN2000 Series Pneumatic Piston Actuators



## 4.6 Fitting the handwheel to TN2000RH actuators

- Remove the cover (21) from the actuator, see Figure 11.
- Remove the dust cap from the top of the handwheel assembly **C**.
- Insert the plunger **E** and tighten the securing bolt **B**.
- Ensure the indicator is at the highest point.
- Fit the handwheel assembly **A** over the upper spindle.
- Fit and tighten the securing bolts **D** to a torque of 50 Nm.
- Fit the dust cap **C**.

### 4.6.1 Removal of handwheel TN2000RH

- Ensure indicator is at the highest position.
- Loose and remove 4 securing bolts **D**.
- Remove handwheel assembly.

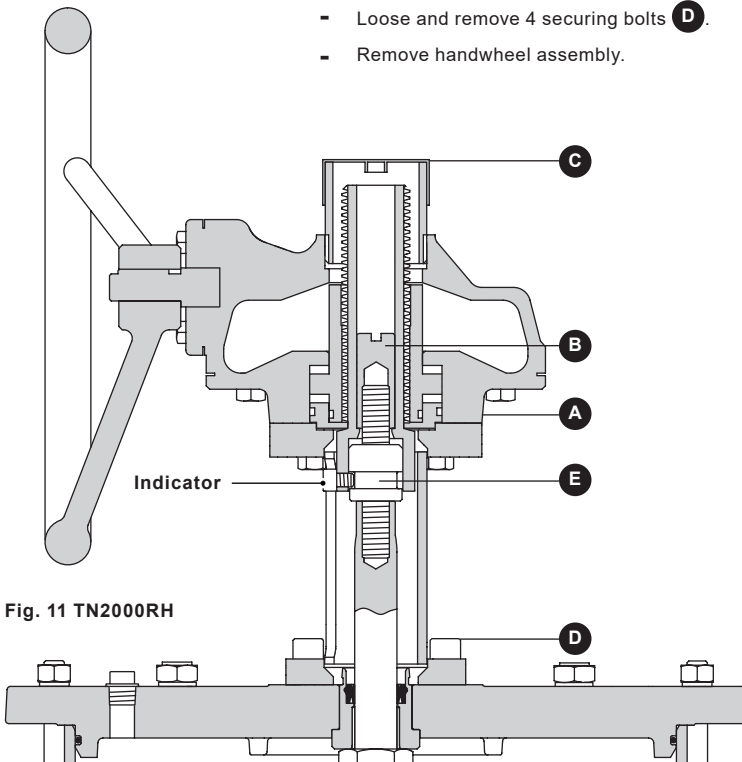

Fig. 11 TN2000RH

## 4.7 Fitting the handwheel to TN2000 EH actuators

- Remove the cover (21) from the actuator, see Figure 12.
- Remove the dust cap from the top of the handwheel assembly **(C)**.
- Fit the handwheel spacer **(F)** over the spindle and locate it on the bearing and seal insert.
- Ensure the indicator is at the lowest point.
- Fit the handwheel assembly **(A)**.
- Fit and tighten the securing bolts **(D)** to a torque of 50 Nm.
- Insert and tighten the securing bolt **(B)**.
- Fit the dust cap **(C)**.

### 4.7.1 Removal of handwheel TN2000EH

- Ensure indicator is at the lowest position.
- Remove dust cap **(C)**.
- Loosen and remove securing bolt **(B)**.
- Loosen and remove 4 securing bolts **(D)**.
- Remove handwheel assembly.

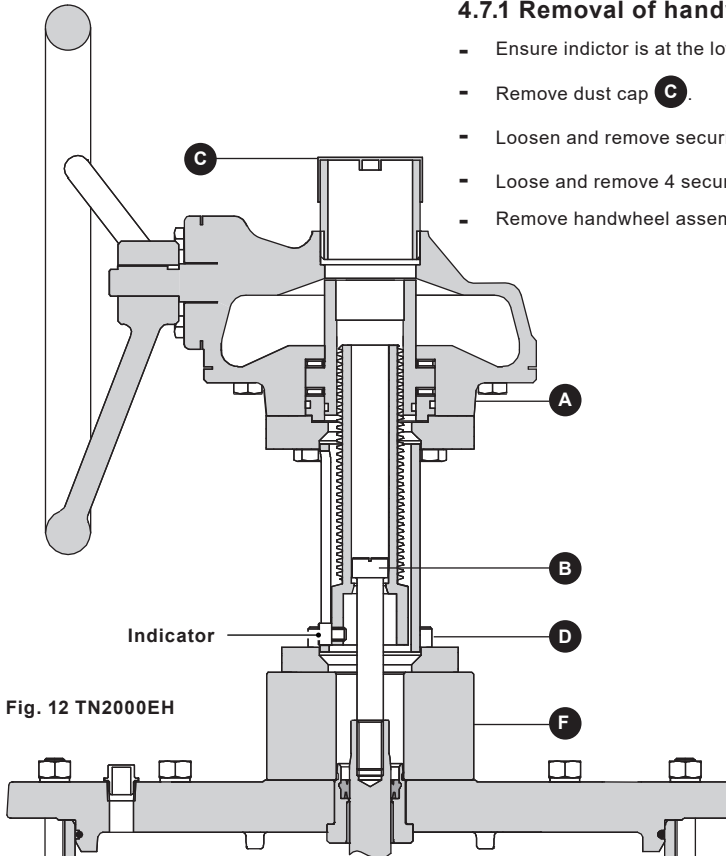

Fig. 12 TN2000EH

# 5. Spare parts

The spare parts available are common across the range of actuators detailed in this document. No other parts are available as spares.

## Available spares

'O' ring kit	15, 29, 30, 31
Travel indicator kit	22, 27, 28
Spring	6
Handwheel	A
EH kit	B
RH kit	C

## How to order spares

Always order spares by using the description given in the column headed 'Available spares' and state the actuator model.

Example: 1 - 'O' ring kit for a Spirax Sarco TN2277SE pneumatic piston actuator.

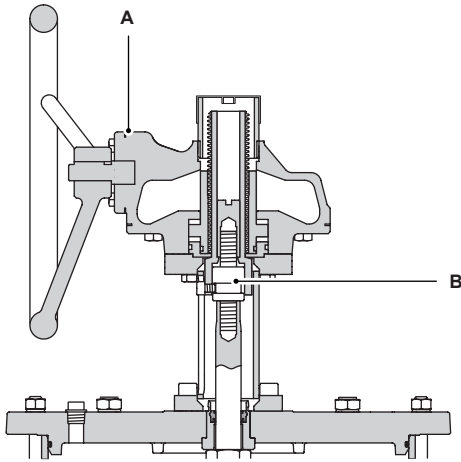

Fig. 13

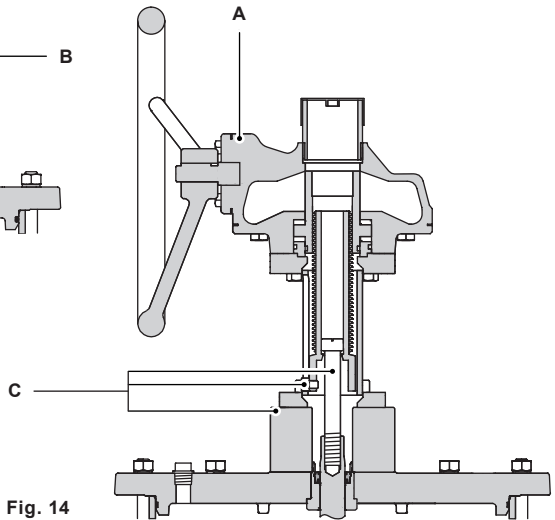

Fig. 14

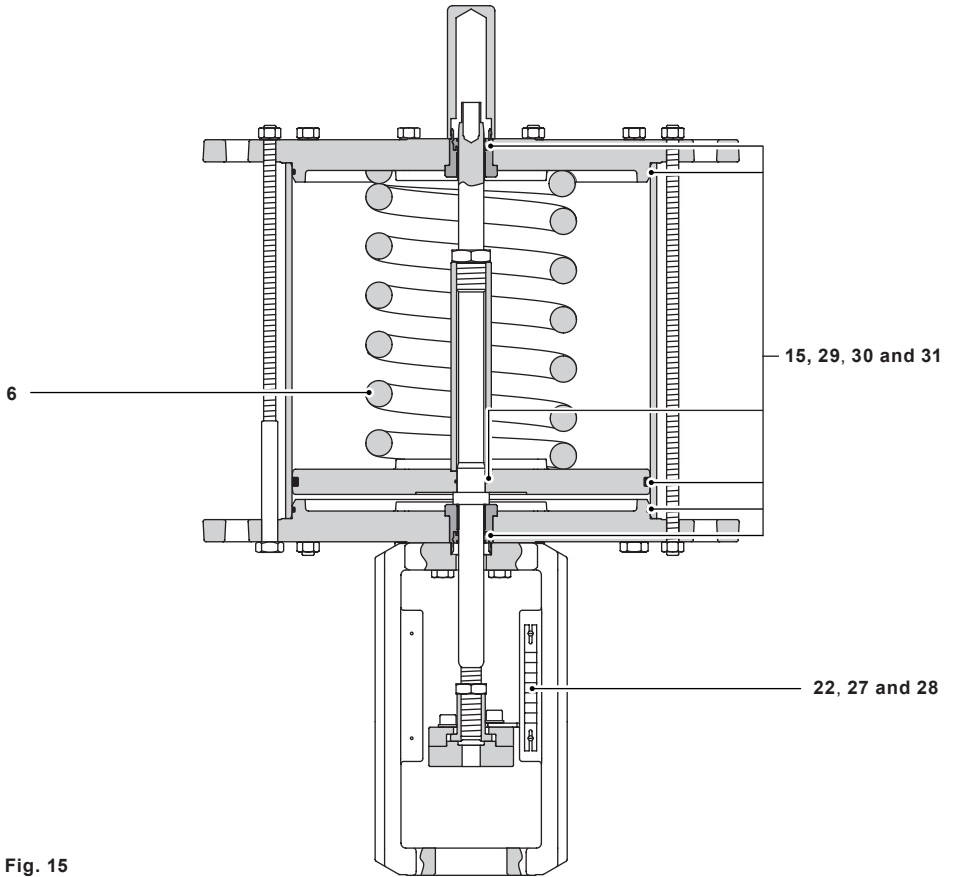

Fig. 15

