

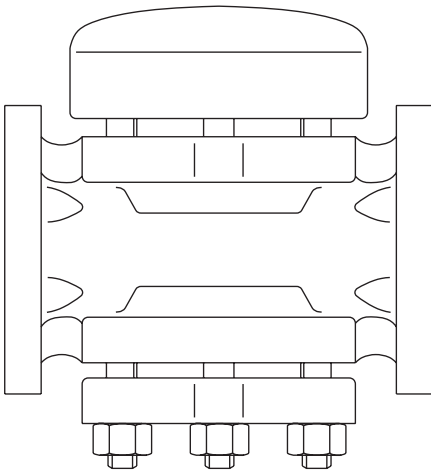

**spirax**  
**sarco****TD62LM and TD62M**  
**Thermodynamic Steam Traps**  
**with Replaceable Seats**  
Installation and Maintenance Instructions

1. Safety information
2. General product information
3. Installation
4. Commissioning
5. Operation
6. Maintenance
7. Spare parts

# 1. Safety information

Safe operation of these products can only be guaranteed if they are properly installed, commissioned, used and maintained by qualified personnel (see Section 1.11) in compliance with the operating instructions. General installation and safety instructions for pipeline and plant construction, as well as the proper use of tools and safety equipment must also be complied with.

## 1.1 Intended use

Referring to the Installation and Maintenance Instructions, name-plate and Technical Information Sheet, check that the product is suitable for the intended use/application. These products comply with the requirements of the Pressure Equipment Directive (PED) and all fall within category 'SEP'. It should be noted that products within this category are required by the Directive not to carry the  mark.

- i) These products have been specifically designed for use on steam, air or condensate/water, which is in Group 2 of the above mentioned Pressure Equipment Directive. The products' use on other fluids may be possible but, if this is contemplated, Spirax Sarco should be contacted to confirm the suitability of the product for the application being considered.
- ii) Check material suitability, pressure and temperature and their maximum and minimum values. If the maximum operating limits of the product are lower than those of the system in which it is being fitted, or if malfunction of the product could result in a dangerous overpressure or overtemperature occurrence, ensure a safety device is included in the system to prevent such over-limit situations.
- iii) Determine the correct installation situation and direction of fluid flow.
- iv) Spirax Sarco products are not intended to withstand external stresses that may be induced by any system to which they are fitted. It is the responsibility of the installer to consider these stresses and take adequate precautions to minimise them.
- v) Remove protection covers from all connections and protective film from all name-plates, where appropriate, before installation on steam or other high temperature applications.

## 1.2 Access

Ensure safe access and if necessary a safe working platform (suitably guarded) before attempting to work on the product. Arrange suitable lifting gear if required.

## 1.3 Lighting

Ensure adequate lighting, particularly where detailed or intricate work is required.

## 1.4 Hazardous liquids or gases in the pipeline

Consider what is in the pipeline or what may have been in the pipeline at some previous time. Consider: flammable materials, substances hazardous to health, extremes of temperature.

## 1.5 Hazardous environment around the product

Consider: explosion risk areas, lack of oxygen (e.g. tanks, pits), dangerous gases, extremes of temperature, hot surfaces, fire hazard (e.g. during welding), excessive noise, moving machinery.

## 1.6 The system

Consider the effect on the complete system of the work proposed. Will any proposed action (e.g. closing isolation valves, electrical isolation) put any other part of the system or any personnel at risk?

Dangers might include isolation of vents or protective devices or the rendering ineffective of controls or alarms. Ensure isolation valves are turned on and off in a gradual way to avoid system shocks.

## 1.7 Pressure systems

Ensure that any pressure is isolated and safely vented to atmospheric pressure. Consider double isolation (double block and bleed) and the locking or labelling of closed valves. Do not assume that the system has depressurised even when the pressure gauge indicates zero.

## 1.8 Temperature

Allow time for temperature to normalise after isolation to avoid the danger of burns.

## 1.9 Tools and consumables

Before starting work ensure that you have suitable tools and/or consumables available. Use only genuine Spirax Sarco replacement parts.

## 1.10 Protective clothing

Consider whether you and/or others in the vicinity require any protective clothing to protect against the hazards of, for example, chemicals, high /low temperature, radiation, noise, falling objects, and dangers to eyes and face.

## 1.11 Permits to work

All work must be carried out or be supervised by a suitably competent person. Installation and operating personnel should be trained in the correct use of the product according to the Installation and Maintenance Instructions.

Where a formal 'permit to work' system is in force it must be complied with. Where there is no such system, it is recommended that a responsible person should know what work is going on and, where necessary, arrange to have an assistant whose primary responsibility is safety.

Post 'warning notices' if necessary.

## 1.12 Handling

Manual handling of large and/or heavy products may present a risk of injury. Lifting, pushing, pulling, carrying or supporting a load by bodily force can cause injury particularly to the back. You are advised to assess the risks taking into account the task, the individual, the load and the working environment and use the appropriate handling method depending on the circumstances of the work being done.

## 1.13 Residual hazards

In normal use the external surface of the product may be very hot. If used at the maximum permitted operating conditions the surface temperature of some products may reach temperatures of 500 °C (932 °F).

Many products are not self-draining. Take due care when dismantling or removing the product from an installation (refer to 'Installation and Maintenance Instructions').

## 1.14 Freezing

Provision must be made to protect products which are not self-draining against frost damage in environments where they may be exposed to temperatures below freezing point.

## **1.15 Safety information - product specific**

See Section 6 'Maintenance' of this document for specific details relating to these products.

## **1.16 Disposal**

Unless otherwise stated in the Installation and Maintenance Instructions, this product is recyclable and no ecological hazard is anticipated with its disposal providing due care is taken.

## **1.17 Returning products**

Customers and stockists are reminded that under EC Health, Safety and Environment Law, when returning products to Spirax Sarco they must provide information on any hazards and the precautions to be taken due to contamination residues or mechanical damage which may present a health, safety or environmental risk. This information must be provided in writing including Health and Safety data sheets relating to any substances identified as hazardous or potentially hazardous.

## 2. General product information

### 2.1 General description

The **TD62LM** and **TD62M** are maintainable high pressure thermodynamic steam traps with integral strainer and a replaceable seat to ease maintenance. They have been designed specifically for steam mains drainage applications. The body castings are produced by a TÜV approved supplier in accordance with AD-Merkblatt WO/TRD100 and are available with screwed, socket weld or flanged connections.

The **TD62LM** is specifically designed for relatively small condensate loads on superheat and mains drainage applications.

An insulating cover is fitted as standard on both the TD62M and TD62LM.

#### Available types

**TD62LM** with low capacity orifice.

**TD62M** with standard orifice.

#### Standards

This product fully complies with the requirement of the Pressure Equipment Directive (PED).

#### Certification

This product is available with certification to EN 10204 3.1.

**Note:** All certification/inspection requirements must be stated at the time of order placement.

**Note:** For additional information see the following Technical Information Sheets:

TI-P068-08 (screwed and socket weld),

TI-P068-19 (EN body with flanged connections),

TI-P068-20 (ASTM body with flanged connections).

### 2.2 Sizes and pipe connections

#### ASTM body - ASTM A217 WC6

½", ¾" and 1" with screwed NPT or socket weld (ASME/ANSI B 16.11 Class 3000) connections DN15, DN20 and DN25 - standard flanges ASME/ANSI B 16.5 Class 300 and 600, JIS/KS 40.

#### EN body - EN 10213-2 G17 CrMo5-5+QT

DN15, DN20 and DN25 - standard flange EN 1092 PN100.

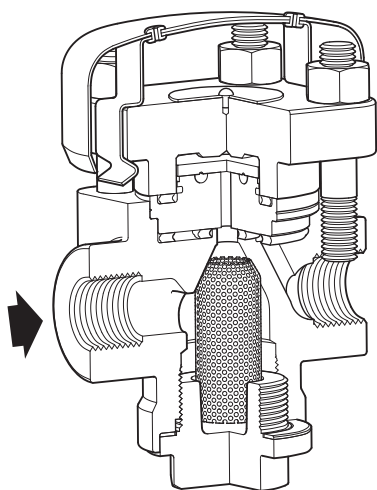

Fig. 1 Screwed/socket weld

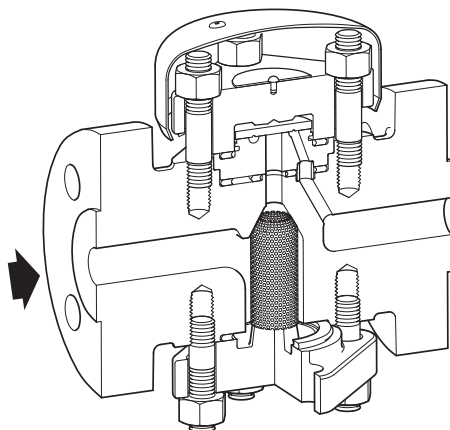
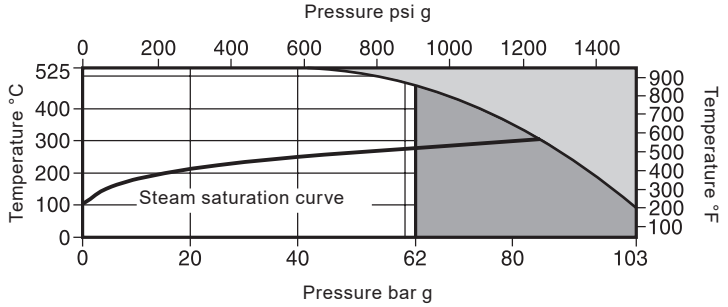

Fig. 2 Flanged

## 2.3 Pressure/temperature limits

**Screwed and socket weld**



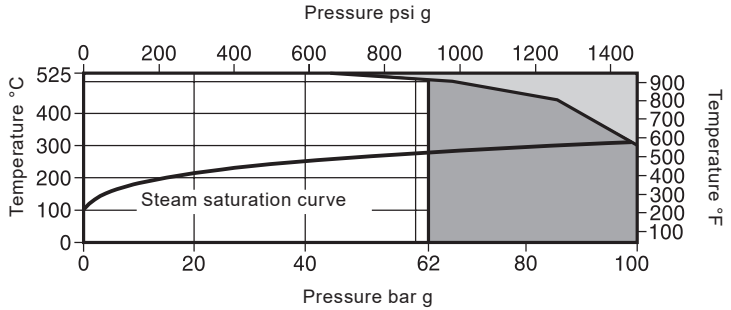

**EN (flanged)**

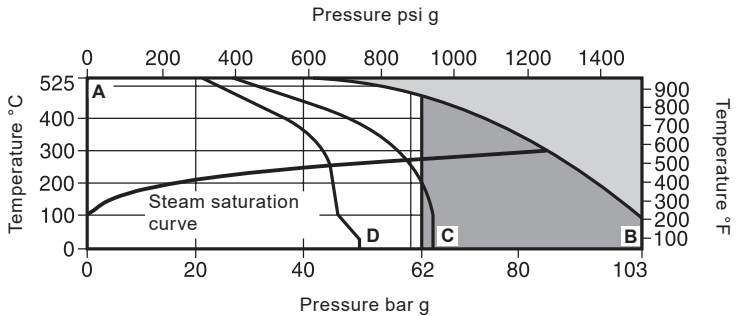

**ASTM (flanged)**



 The product **must not** be used in this region.

 The product should not be used in this region or beyond its operating range as damage to the internals may occur.

**A - B** Flanged to ASME/ANSI B 16.5 Class 600

**A - C** Flanged to JIS/KS 40

**A - D** Flanged to ASME/ANSI B 16.5 Class 300

Body design conditions		<b>Screwed</b>	ASME/ANSI 600	
		<b>Socket weld</b>	ASME/ANSI 600	
		<b>EN body</b>	PN100	
		<b>ASTM body</b>	ASME/ANSI 600	
PMA	Maximum allowable pressure	<b>Screwed</b>	103 bar g @ 93 °C	(1 494 psi g @ 199 °F)
		<b>Socket weld</b>	103 bar g @ 93 °C	(1 494 psi g @ 199 °F)
		<b>EN body</b>	98.1 bar g @ 300 °C	(1 422 psi g @ 572 °F)
		<b>ASTM body</b>	103 bar g @ 93 °C	(1 494 psi g @ 199 °F)
TMA	Maximum allowable temperature	525 °C @ 42.7 bar g (977 °F @ 619 psi g)		
Minimum allowable temperature	<b>Screwed</b>	0 °C (32 °F)		
	<b>Socket weld</b>	0 °C (32 °F)		
	<b>EN</b>	-10 °C (14 °F)		
	<b>ASTM</b>	0 °C (32 °F)		
PMO	Maximum operating pressure for steam service	62 bar g @ 482 °C (899 psi g @ 899 °F)		
TMO	Maximum operating temperature	525 °C @ 42.7 bar g (977 °F @ 619 psi g)		
Minimum operating temperature	<b>TD62LM</b>	0 °C (32 °F)		
	<b>TD62M</b>	0 °C (32 °F)		
PMOB	Maximum operating backpressure	<b>TD62LM</b>	50% of upstream pressure	
		<b>TD62M</b>	80% of upstream pressure	
Minimum operating pressure <b>Note:</b> These figures relate to normal operating conditions and not start-up.	<b>TD62LM</b>	Low capacity version	8 bar g @ 175 °C	(116 psi g @ 347 °F)
	<b>TD62M</b>	Standard version	1.4 bar g @ 126 °C	(20 psi g @ 259 °F)
Designed for a maximum cold hydraulic test pressure of:	<b>ASTM</b>	155 bar g (2 248 psi g)		
	<b>EN</b>	150 bar g (2 175 psi g)		

# 3. Installation

**Note:** Before actioning any installation observe the 'Safety information' in Section 1.

Referring to the Installation and Maintenance Instructions, name-plate and Technical Information Sheet, check that the product is suitable for the intended installation.

**3.1** Check materials, pressure and temperature and their maximum values. If the maximum operating limit of the product is lower than that of the system in which it is being fitted, ensure that a safety device is included in the system to prevent overpressurisation.

**3.2** Determine the correct installation situation and the direction of fluid flow.

**3.3** Remove protective covers from all connections and protective film from all name-plates, where appropriate, before installation on steam or other high temperature applications.

**3.4** The preferred installation is in a horizontal pipe with the insulating cover uppermost (see Figure 3). The trap will operate in any position, but the service life may be affected.

**Note:** When a socket weld trap is being installed the welding should be carried out to an approved procedure of a recognised standard.

**3.5** Observe the flow direction markings on the trap body. Stop valves should be installed so as to permit the isolation of the trap from both supply and return line pressure. If the trap discharges to atmosphere, the discharge should be directed to a safe place.

**Note:** the disc and seating surfaces of these traps have been produced to a high degree of flatness to achieve good shut-off under high pressure conditions. An integral strainer helps prevent dirt and scale from entering the trap. If particles become entrapped between the disc and seat, the high flow velocities can cause rapid wear and erosion. A separate strainer and/or dirt pocket will provide additional protection.

**3.6** Access for removal of the integral strainer screen should be provided.

**3.7** The insulating cover may be removed to facilitate installation, but it must be replaced before the trap is put into service.

**Note:** If the trap is to discharge to atmosphere ensure it is to a safe place, the discharging fluid may be at a temperature of 100 °C (212 °F).



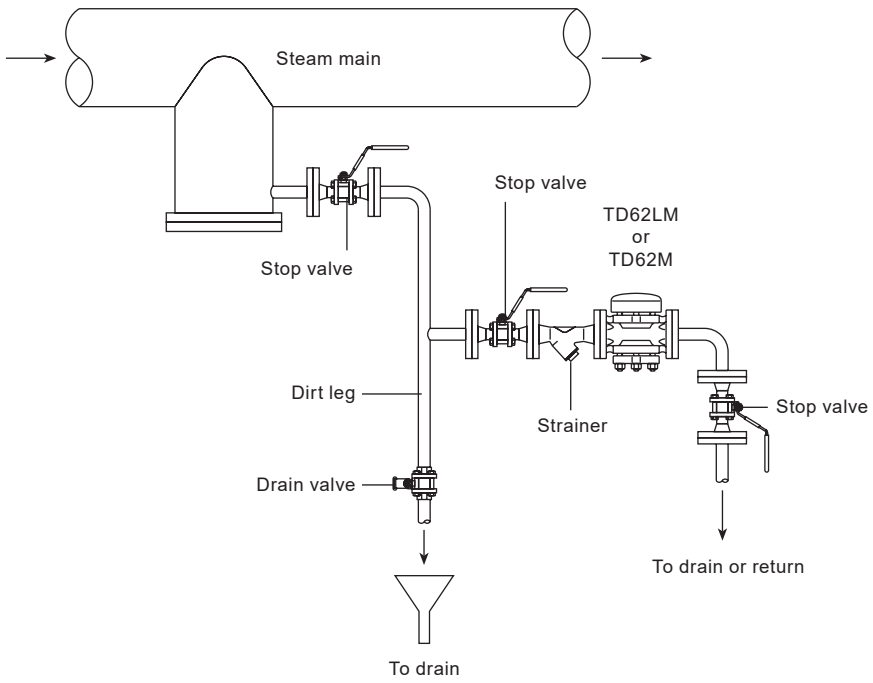

**Alternative layout**

Suggested drop leg if the TD62LM or TD62M is located more than 2 m (6 ft) away from the main drop leg.

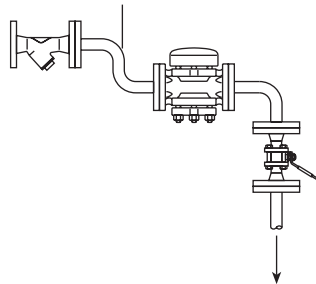

**Fig. 3 Typical installation**

## 4. Commissioning

### 4.1 General information

After installation or maintenance ensure that the system is fully functioning. Carry out tests on any alarms or protective devices.

### 4.2 Commissioning with particular reference to venting air

(refer to Figure 4).

With high pressure systems, initial start-up can take several hours (or days) to bring the system to normal operating pressure and temperature. Even if the trap has replaced another trap while the main system has remained running, it may still be necessary to vent air from the drop leg. If the trap is some distance from stop valve 'A', it could be possible to air lock the pipework between valve 'A' and the TD62M or TD62LM (i.e. the trap closes to air and does not readily allow steam to enter the pipework). To overcome this on start-up the following procedure should be adopted. With stop valve 'B' closed, drain valve 'C' open, slowly and partially open stop valve 'A'. This will discharge the air, condensate and any pipe debris. Valve 'C' should be fully closed, and valves 'A' and 'B' slowly opened to the fully open position.

When the trap is more than 2 m (6 ft) away from the vertical drain leg, a suitable drop leg at the inlet to the trap can improve its service life by ensuring that the trap does not see a mixture of steam and condensate.

#### Important note:

**After the trap has been in service at normal operating pressure and temperature for 24 hours, it is essential that the cover nuts are retightened (see Table 1 page 14 for the recommended tightening torques). This will ensure the correct compression of the gasket under service conditions.**

## 5. Operation

The TD62LM and TD62M are thermodynamic steam traps which use a disc to control the release of condensate and to trap steam. The trap cycles open and closed to discharge condensate close to steam temperature and closes tight between discharges. The disc, which is the only moving part, rises and falls in response to dynamic forces produced by the partial re-evaporation (flashing) of hot condensate. Cool condensate, air and other non-condensable gases enter the trap through the central orifice, lift the disc, and are discharged through the outlet orifice. When the condensate approaches steam temperature, a portion of it flashes as it enters the trap. The flash steam passes at high velocity over the underside of the disc and collects in the control chamber above. The resulting pressure imbalance forces the disc downward onto the seating surfaces, stopping the flow. The trap remains tightly closed until the loss of heat through the trap body lowers the control chamber pressure, allowing the inlet pressure to raise the disc and repeat the cycle. An insulating cover prevents the trap being unduly influenced by excessive heat loss when subjected to low ambient temperatures, wind, rain, etc.

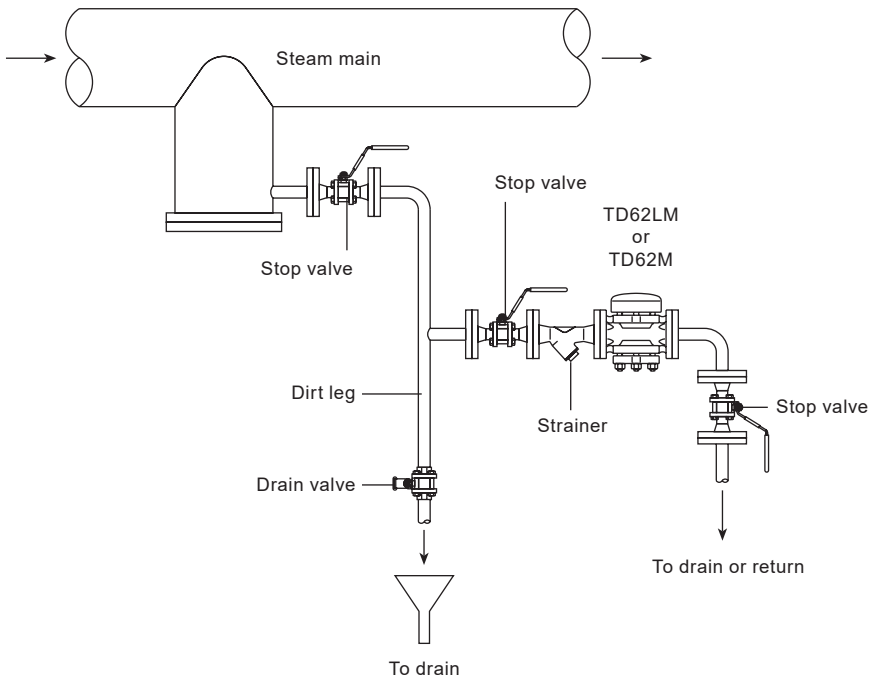

**Alternative layout**

Suggested drop leg if the TD62LM or TD62M is located more than 2 m (6 ft) away from the main drop leg.

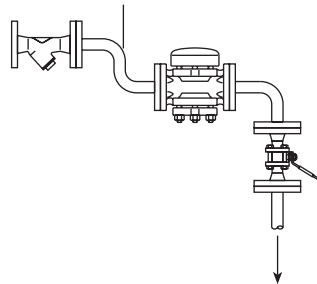

**Fig. 4 Typical installation**

# 6. Maintenance

**Note:** Before actioning any maintenance programme observe the 'Safety information' in Section 1.

## Warning

The cover gasket contains a thin stainless steel support ring which may cause physical injury if not handled and disposed of carefully.

### 6.1 How to fit the disc and seat:

- Spring off the insulating cover (5), unscrew the four nuts (9) and remove the top cover (2).
- Lift off the disc (6).
- Remove the cover gasket (10) and lift out the seat unit (7). The use of 2 screwdrivers inserted into the groove may ease removal. Ensure that the location ferrule (15) is also removed.
- Carefully remove the seat gaskets (13 + 14) from the body of the trap. Ensure that no damage is caused to the trap body.
- Ensure that the gasket contact surface in the body is clean and fit new seat gaskets (13 + 14).
- Fit the new seat unit (7) ensuring that the location ferrule (15) is firmly located in the body.
- Fit the new cover gasket (10) and fit a new disc (6). Ensure that the disc is fitted with the grooves facing the seat.
- Replace the top cover (2) ensuring the cover gasket remains in place.
- Replace the 4 nuts (9).  
Tighten the nuts diagonally in sequence to a recommended torque of 45 - 50 N m (33 - 37 lbf ft).  
**Note:** The use of a thread lubricant is recommended. Replace the insulating cover (5).
- After 24 hours check the torque on the top cover nuts (9).
- Always open the isolation valves slowly and check for leaks.

**Table 1 Recommended tightening torques**



Item	Part	 or mm		N m	(lbf ft)
3	Strainer cap	32 A/F		142 - 158	(105 - 107)
8 and 8A	Cover studs		M10 x 30	20 - 25	(15 - 18)
9	Cover nuts	17 A/F		45 - 50	(33 - 37)

Fig. 5 Screwed and socket weld

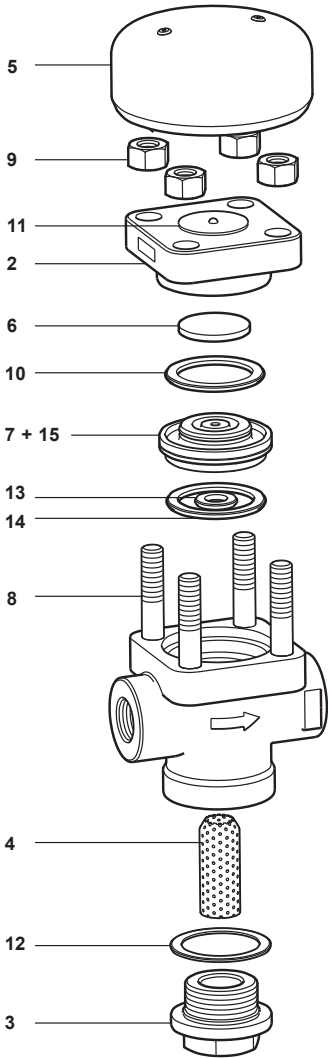
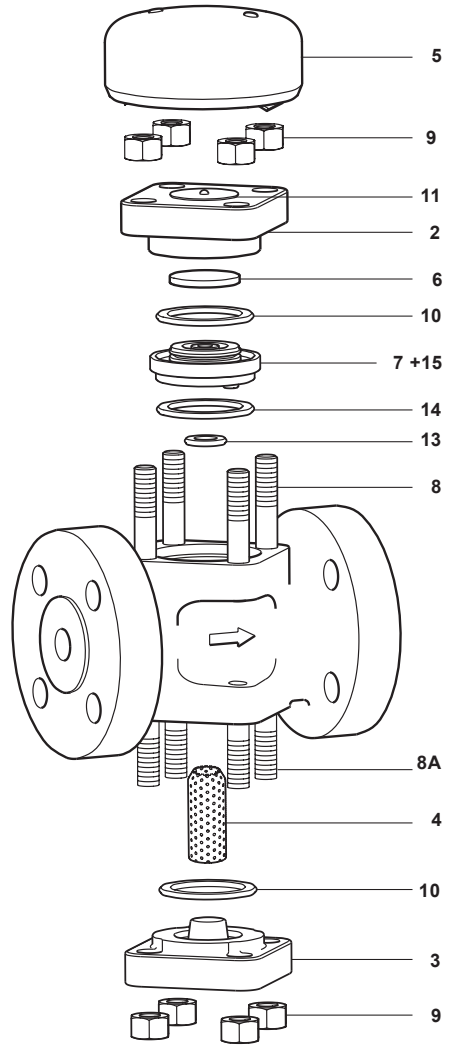

Fig. 6 Flanged



## 6.2 How to clean or replace the strainer screen:

**Note:** On older models the strainer was a 0.8 mm perforated screen. Newer models use a 100 mesh screen to provide improved screening. The screens are interchangeable.

### Screwed and socket weld connections (Figure 7)

- Access to the strainer screen can be obtained by removing strainer cap (3).
- Remove the strainer screen (4).
- Fit a new or cleaned strainer screen into the recess in the cap (3).
- A new gasket (12) should be fitted and the cap (3) screwed into the body and tightened to the recommended torque (see Table 1).

**Note:** The use of a thread lubricant is recommended.

### Flanged connections (Figure 8)

- Unscrew the four bottom cover nuts (9) and remove the bottom cover (3).
- Remove the strainer screen (4) and inspect. Locate the new screen or replace a cleaned screen onto the spigot on the bottom cover (3).
- Reassemble the cover (3) to the body using a new gasket (10) ensuring that the gasket faces are perfectly clean.
- The cover nuts (9) should be tightened to the recommended torque in a diagonally opposite sequence (see Table 1). After 24 hours in service the cover nuts should be checked for tightness.

**Note:** The use of a thread lubricant is recommended.

## 6.3 How to replace the cover studs:

### Screwed and socket weld connections (Figure 7)

After removing old cover studs (8), fit new cover studs until the studs bottom out.

**Note:** The use of a thread lubricant is recommended.

### Flanged connections (Figure 8)

The flanged TD62M and TD62LM are fitted with two different lengths of studs. It is therefore important that the correct length of stud is fitted into the correct tapped holes in the body. The studs are packed in separate labelled bags (A, B, C, D), within the spares pack. The stud holes are as marked on the diagrams in Figure 11. Fit new studs to the recommended torque (see Table 1) until they bottom out.

**Note:** The use of a thread lubricant is recommended.

**Table 1 Recommended tightening torques**



Item	Part	 or  mm	N m	(lbf ft)
3	Strainer cap	32 A/F	142 - 158	(105 - 107)
8 and 8A	Cover studs	M10 x 30	20 - 25	(15 - 18)
9	Cover nuts	17 A/F	45 - 50	(33 - 37)

Fig. 7 Screwed and socket weld

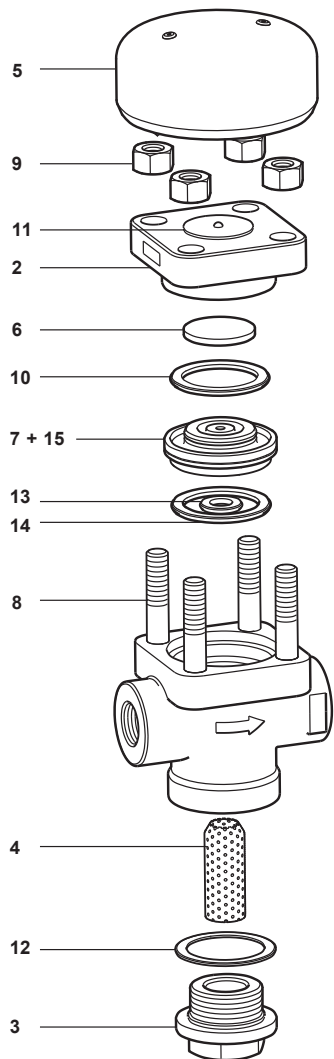
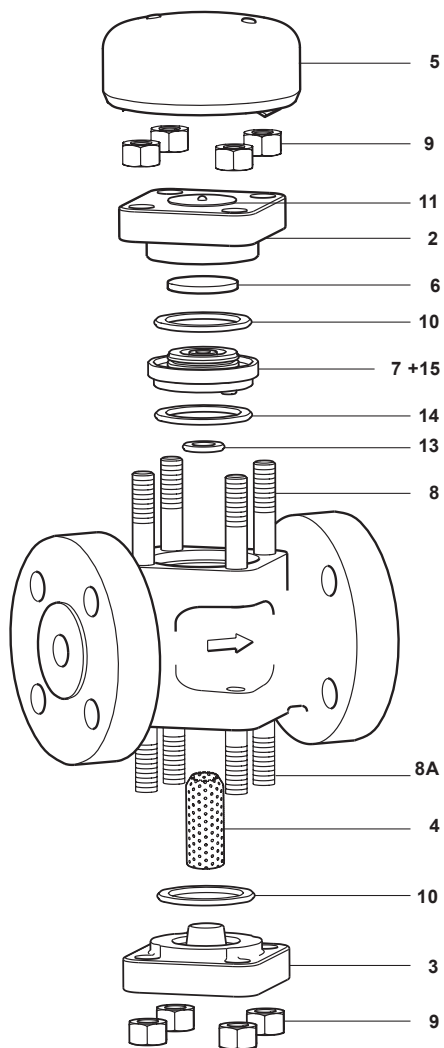

Fig. 8 Flanged



## 7. Spare parts

The spare parts available are shown in heavy outline. Parts drawn in a grey line are not supplied as spares (Figures 9 and 10).

### Available spares

Screwed/socket weld		
Description	Spirax Sarco stock No.	Item No.
Insulating cover	0685685	5
Set of cover studs and nuts (set of 4)	0685681	8, 9
Seat and disc assembly	<b>TD62LM</b>	<b>6, 7, 10, 13, 14, 15</b>
	<b>TD62M</b>	<b>6, 7, 10, 13, 14, 15</b>
Strainer screen	0685682	4
Set of gaskets (packet of 3 sets)	0686582	10, 12, 13, 14
Strainer cap gasket (3 off)	0686584	12
Flanged - ASTM body		
Description	Spirax Sarco stock No.	Item No.
Insulating cover	0685685	5
Set of cover studs and nuts (set of 8) *	0685687	8, 8A, 9
Seat and disc assembly	<b>TD62LM</b>	<b>6, 7, 10, 13, 14, 15</b>
	<b>TD62M</b>	<b>6, 7, 10, 13, 14, 15</b>
Strainer screen	0685682	4
Set of gaskets (packet of 3 sets)	0686583	10, 13, 14
Cover gasket (3 off)	0686585	10

\* **Note:** There are 2 sets of 4 studs which make-up the cover stud and nut set. They are marked 'T' for top studs and 'B' for bottom studs (see Figure 11). Care should be taken to ensure that the correct studs are fitted into the correct tappings, see Section 6.3 - Flanged connections + Figure 11.



Fig. 9 Screwed and socket weld

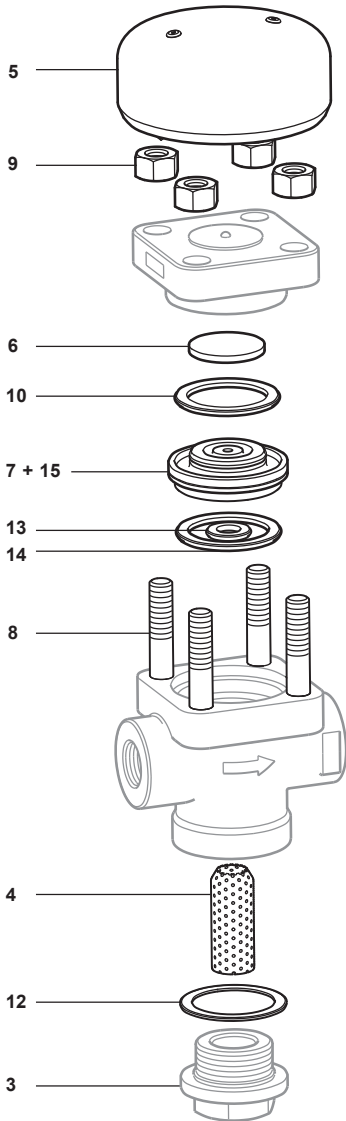
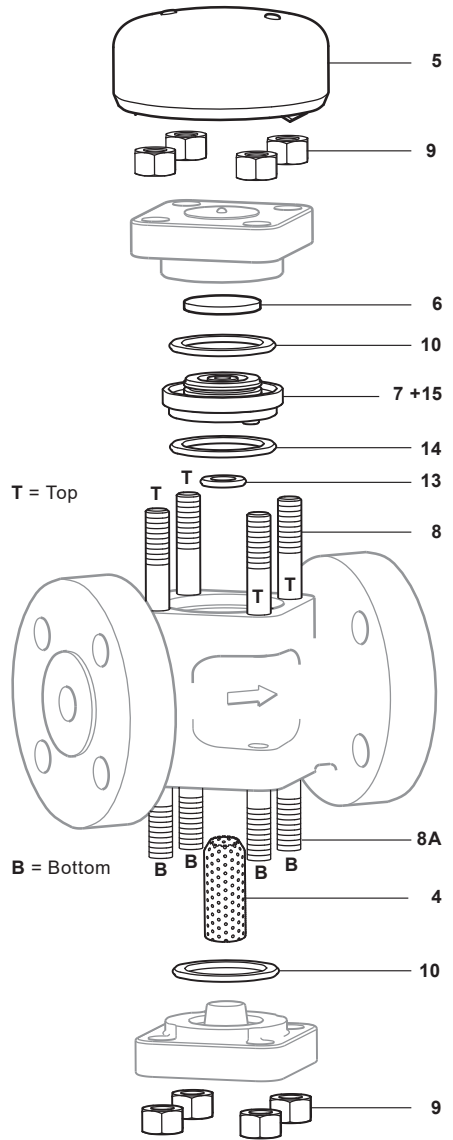

Fig. 10 Flanged



## Flanged - EN body

Description	Spirax Sarco stock No.	Item No.
Insulating cover	0685685	<b>5</b>
Set of cover studs and nuts (set of 8)	0685688	<b>8, 8A, 9</b>
Seat and disc assembly	<b>TD62LM</b>	<b>6, 7, 10, 13, 14, 15</b>
	<b>TD62M</b>	<b>6, 7, 10, 13, 14, 15</b>
Strainer screen	0685682	<b>4</b>
Set of gaskets (packet of 3 sets)	0686583	<b>10, 13, 14</b>
Cover gasket (3 off)	0686585	<b>10</b>

\* **Note:** There are 2 sets of 4 studs which make-up the cover stud and nut set. They are marked 'T' for top studs and 'B' for bottom studs (see Figure 11). Care should be taken to ensure that the correct studs are fitted into the correct tappings, see Section 6.3 - Flanged connections + Figure 11.

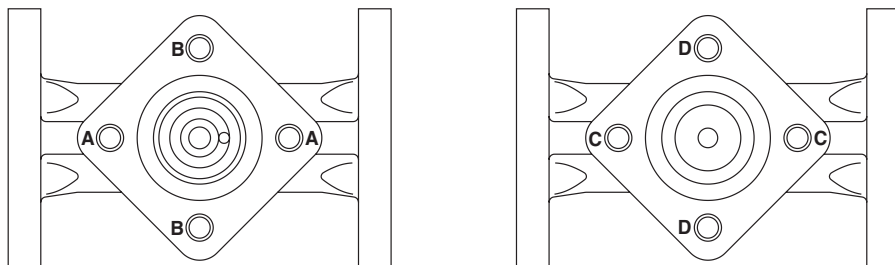

**Fig. 11**

## How to order spares

Always order spares by using the description given in the column headed 'Available spares', and state the size and type of trap.

**Example:** 1 - Insulating cover for a DN15, TD62LM thermodynamic steam trap, having a flanged - ASTM body. Stock No. 0685685.

Fig. 12 Screwed and socket weld

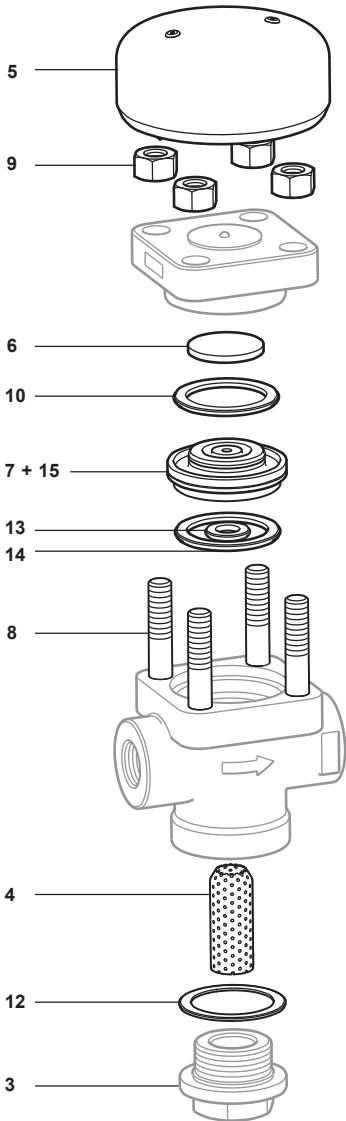

Fig. 13 Flanged

