

TD32F

Flanged Thermodynamic Steam Traps

Installation and Maintenance Instructions

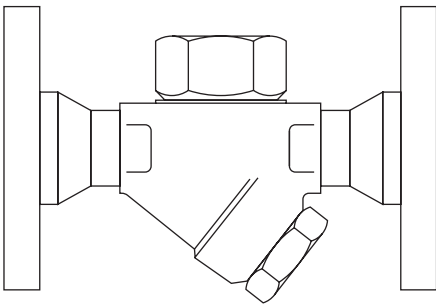

1. Safety information
2. General product information
3. Installation
4. Commissioning
5. Operation
6. Maintenance
7. Spare parts

1. Safety information

Safe operation of these products can only be guaranteed if they are properly installed, commissioned, used and maintained by qualified personnel (see Section 1.11) in compliance with the operating instructions. General installation and safety instructions for pipeline and plant construction, as well as the proper use of tools and safety equipment must also be complied with.

1.1 Intended use

Referring to the Installation and Maintenance Instructions, name-plate and Technical Information Sheet, check that the product is suitable for the intended use/application. These products comply with the requirements of the European Pressure Equipment Directive 2014/68/EU and all fall within category 'SEP'.

It should be noted that products within this category are required by the Directive not to carry the  mark.

- i) These products have been specifically designed for use on steam, air or condensate/water, which is in Group 2 of the above mentioned Pressure Equipment Directive. The products' use on other fluids may be possible but, if this is contemplated, Spirax Sarco should be contacted to confirm the suitability of the product for the application being considered.
- ii) Check material suitability, pressure and temperature and their maximum and minimum values. If the maximum operating limits of the product are lower than those of the system in which it is being fitted, or if malfunction of the product could result in a dangerous overpressure or overtemperature occurrence, ensure a safety device is included in the system to prevent such over-limit situations.
- ii) Determine the correct installation situation and direction of fluid flow.
- iv) Spirax Sarco products are not intended to withstand external stresses that may be induced by any system to which they are fitted. It is the responsibility of the installer to consider these stresses and take adequate precautions to minimise them.
- v) Remove protection covers from all connections and protective film from all name-plates, where appropriate, before installation on steam or other high temperature applications.

1.2 Access

Ensure safe access and if necessary a safe working platform (suitably guarded) before attempting to work on the product. Arrange suitable lifting gear if required.

1.3 Lighting

Ensure adequate lighting, particularly where detailed or intricate work is required.

1.4 Hazardous liquids or gases in the pipeline

Consider what is in the pipeline or what may have been in the pipeline at some previous time. Consider: flammable materials, substances hazardous to health, extremes of temperature.

1.5 Hazardous environment around the product

Consider: explosion risk areas, lack of oxygen (e.g. tanks, pits), dangerous gases, extremes of temperature, hot surfaces, fire hazard (e.g. during welding), excessive noise, moving machinery.

1.6 The system

Consider the effect on the complete system of the work proposed. Will any proposed action (e.g. closing isolation valves, electrical isolation) put any other part of the system or any personnel at risk?

Dangers might include isolation of vents or protective devices or the rendering ineffective of controls or alarms. Ensure isolation valves are turned on and off in a gradual way to avoid system shocks.

1.7 Pressure systems

Ensure that any pressure is isolated and safely vented to atmospheric pressure. Consider double isolation (double block and bleed) and the locking or labelling of closed valves. Do not assume that the system has depressurised even when the pressure gauge indicates zero.

1.8 Temperature

Allow time for temperature to normalise after isolation to avoid the danger of burns.

1.9 Tools and consumables

Before starting work ensure that you have suitable tools and/or consumables available. Use only genuine Spirax Sarco replacement parts.

1.10 Protective clothing

Consider whether you and/or others in the vicinity require any protective clothing to protect against the hazards of, for example, chemicals, high /low temperature, radiation, noise, falling objects, and dangers to eyes and face.

1.11 Permits to work

All work must be carried out or be supervised by a suitably competent person. Installation and operating personnel should be trained in the correct use of the product according to the Installation and Maintenance Instructions.

Where a formal 'permit to work' system is in force it must be complied with. Where there is no such system, it is recommended that a responsible person should know what work is going on and, where necessary, arrange to have an assistant whose primary responsibility is safety.

Post 'warning notices' if necessary.

1.12 Handling

Manual handling of large and/or heavy products may present a risk of injury. Lifting, pushing, pulling, carrying or supporting a load by bodily force can cause injury particularly to the back. You are advised to assess the risks taking into account the task, the individual, the load and the working environment and use the appropriate handling method depending on the circumstances of the work being done.

1.13 Residual hazards

In normal use the external surface of the product may be very hot. If used at the maximum permitted operating conditions the surface temperature of some products may reach temperatures of 500 °C (932 °F).

Many products are not self-draining. Take due care when dismantling or removing the product from an installation (refer to 'Maintenance instructions').

1.14 Freezing

Provision must be made to protect products which are not self-draining against frost damage in environments where they may be exposed to temperatures below freezing point.

1.15 Safety information - product specific

See Section 6 'Maintenance' of this document for specific details relating to these products.

1.16 Disposal

Unless otherwise stated in the Installation and Maintenance Instructions, this product is recyclable and no ecological hazard is anticipated with its disposal providing due care is taken.

Please visit the Spirax Sarco product compliance web pages

<https://www.spiraxsarco.com/product-compliance>

for up to date information on any substances of concern that may be contained within this product. Where no additional information is provided on the Spirax Sarco product compliance web page, this product may be safely recycled and/or disposed providing due care is taken. Always check your local recycling and disposal regulations.

1.17 Returning products

Customers and stockists are reminded that under EC Health, Safety and Environment Law, when returning products to Spirax Sarco they must provide information on any hazards and the precautions to be taken due to contamination residues or mechanical damage which may present a health, safety or environmental risk. This information must be provided in writing including Health and Safety data sheets relating to any substances identified as hazardous or potentially hazardous.

2. General product information

2.1 General description

The **TD32F** is a maintainable medium pressure flanged thermodynamic steam trap which has an integral strainer screen fitted to protect the internals from dirt.

The **TD32FLC** is designed specifically for low load applications such as steam mains drainage.

The **TD32FA** and **TD32FALC** are fitted with an anti-air-binding disc to ensure prompt removal of air on start-up.

Optional extras

Insulating cover (for the DN15 and 20 only): To prevent the trap being unduly influenced by excessive heat loss such as when subjected to low outside temperatures, wind, rain etc.

Note: The insulating cover, if required, must be specified at the time of order placement.

Standards

This product fully complies with the requirements of the European Pressure Equipment Directive 2014/68/EU.

Certification

These products are available with certification to EN 10204 2.2.

Note: All certification/inspection requirements must be stated at the time of order placement.

Note: For additional information see the Technical Information Sheet TI-P068-17.

2.2 Sizes and pipe connections

DN15, DN15LC, DN20, DN20LC, DN25 and DN25LC

Flanged ASME B 16.5 Class 150 and 300, DIN 2501 PN40 and JIS/KS 10, 16 and 20.

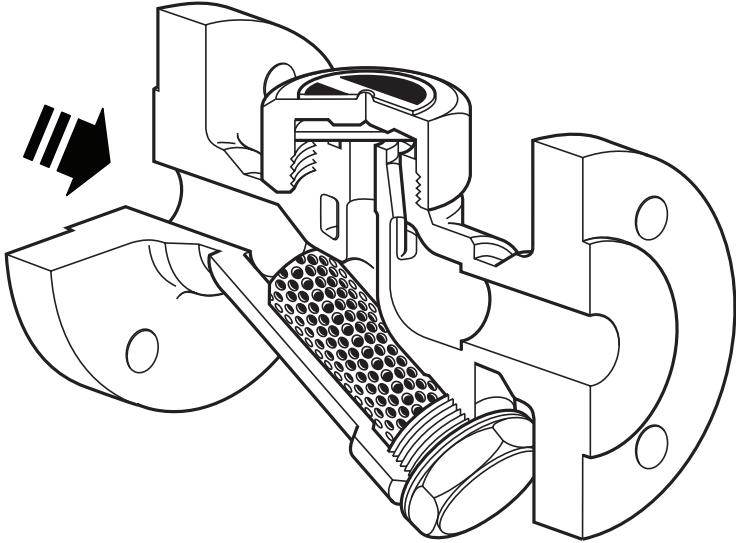

Fig. 1 TD32F

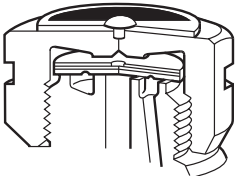

Fig. 2
The TD32FALC version is identified by the groove in the cap

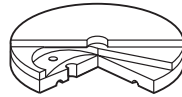
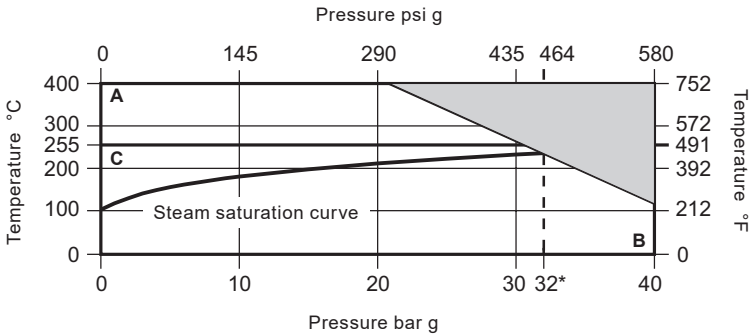

Fig. 3
The TD32FA and TD32FALC have an anti-air-binding disc

2.3 Pressure/temperature limits (ISO 6552)



The product **must not** be used in this region.

PMO Maximum operating pressure for saturated steam service is 32 bar g (464 psi g).

PMOB Maximum operating backpressure is 80% of the upstream pressure.

Note: Minimum operating pressure for satisfactory operation is 0.25 bar g (3.6 psi g).

A - B TD32F and TD32FLC

C - B TD32FA and TD32FALC

Body design conditions		PN40	
PMA	Maximum allowable pressure	40 bar g	(580 psi g)
TMA	Maximum allowable temperature	400 °C	(752 °F)
PMO	Maximum operating pressure	32 bar g	(464 psi g)
TMO	Maximum operating temperature	TD32F and TD32FLC	400 °C (752 °F)
		TD32FA and TD32FALC	255 °C (491 °F)
Minimum operating pressure for satisfactory operation:		0.25 bar g	(3.6 psi g)
PMOB	Maximum operating backpressure is 80% of the upstream pressure		
Product is safe for use under full vacuum conditions			
Designed for a maximum cold hydraulic test pressure of:		60 bar g	(870 psi g)

3. Installation

Note: Before actioning any installation observe the 'Safety information' in Section 1.

Referring to the Installation and Maintenance Instructions, name-plate and Technical Information Sheet, check that the product is suitable for the intended installation:

- 3.1** Check materials, pressure and temperature and their maximum values. If the maximum operating limit of the product is lower than that of the system in which it is being fitted, ensure that a safety device is included in the system to prevent overpressurisation.
- 3.2** Determine the correct installation situation and the direction of fluid flow.
- 3.3** Remove protective covers from all connections.
- 3.4** The trap should preferably be installed in the horizontal plane, with a small drop leg preceding it. Suitable isolation valves must be installed to allow for safe maintenance and trap replacement. Consideration should be given to a suitable method for testing the correct operation of the trap. This may be a sight glass or a Spiratec system. Sight glasses must be positioned a minimum of 1 m (3 ft) downstream of any blast-action traps.
Where the trap discharges into a closed return system, a non-return valve should be fitted downstream to prevent return flow. Remove all packaging and protective covers and ensure all connection ports are clear from obstruction.
Always open isolation valves slowly until normal operating conditions are achieved - this will avoid system shocks. Check for leaks and correct operation. Always ensure the correct tools, safety procedures and protective equipment are used at all times.

Note: If the trap is to discharge to atmosphere ensure it is to a safe place, the discharging fluid may be at a temperature of 100 °C (212 °F).

4. Commissioning

After installation or maintenance ensure that the system is fully functional. Carry out tests on any alarms or protective devices.

5. Operation

The thermodynamic steam trap will discharge condensate with a blast type action at a few degrees below steam saturation temperature, due care must be given to the site of the discharge.

6. Maintenance

Note: Before actioning any maintenance programme observe the 'Safety information' in Section 1.

6.1 General information

Before undertaking any maintenance on the trap it must be isolated from both the supply line and return line and any pressure allowed to safely normalise to atmosphere. The trap should then be allowed to cool. When reassembling, ensure that all joint faces are clean.

6.2 How to service

- Remove insulating cover (7), if fitted, and unscrew the cap (2) using a suitable spanner or socket. Do not use stillsons or a wrench of similar type which may cause distortion of the cap.
- If the seating faces on the body are only slightly worn, they can be refaced by lapping on a flat surface, such as a surface plate. A figure-of-eight motion and a little grinding compound, such as 'Carborundum Co's Compound I.F.' gives the best results. If the wear is too great to be rectified by simple lapping, the seating faces on the body must be ground flat and then lapped.



Note: the disc (3) should always be replaced with a new one. The total amount of metal removed in this way should not exceed 0.25 mm (0.010").

- When reassembling, the disc (3) is normally placed in position with the grooved side in contact with the body seating face.
- Screw on the cap (2) to the recommended tightening torque (see Table 1); no gasket is required but a suitable high temperature anti-seize grease should be applied to the threads.

6.3 How to clean or replace the strainer:

- Unscrew the strainer cap (5) using a suitable spanner.
- Withdraw the screen (4) and clean or, if damaged, replace with a new one.

Table 1 Recommended tightening torques

Item Part	 or  mm	N m	(lbf ft)
2 Cap	DN15LC	36 A/F	135 - 150 (100 - 110)
	DN15	36 A/F	180 - 200 (132 - 147)
	DN20	36 A/F	180 - 200 (132 - 147)
	DN25	36 A/F	250 - 275 (184 - 202)
5 Strainer cap	36 A/F	M28	170 - 190 (125 - 140)

7. Spare parts

The spare parts available are shown in heavy outline. Parts drawn in a grey line are not supplied as spares.

Available spares

Disc for TD32F or TD32FLC (packet of 3)	3
Disc, strainer screen and gasket for TD32FA or TD32FALC	3, 4, 6
Strainer screen and gasket	4, 6
Strainer cap gasket (packet of 3)	6
Insulating cover (for the DN15 and 20 only)	7

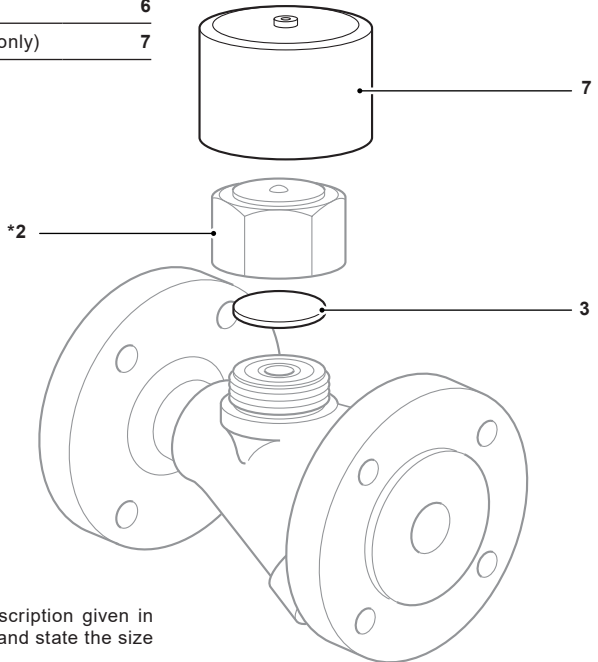

How to order spares

Always order spares by using the description given in the column headed 'Available spares' and state the size and type of trap.

Example:

1 - Strainer screen for a DN15 Spirax Sarco TD32F thermodynamic steam trap.

* **Note:** Items 2 and 5 are not available as spares.

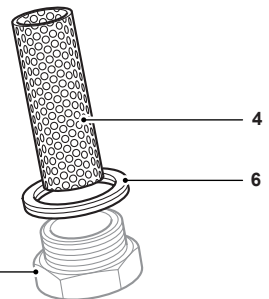

Fig. 4

*5

