

TD120M**Thermodynamic Steam Trap with Replaceable Seat**
Installation and Maintenance Instructions

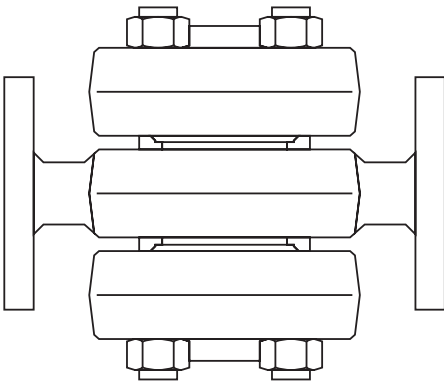

1. Safety information
2. General product information
3. Installation
4. Commissioning
5. Operation
6. Maintenance
7. Spare parts

1. Safety information

Safe operation of this product can only be guaranteed if it is properly installed, commissioned, used and maintained by qualified personnel (see Section 1.11) in compliance with the operating instructions. General installation and safety instructions for pipeline and plant construction, as well as the proper use of tools and safety equipment must also be complied with.

Warning

The cover gasket contains a thin stainless steel support ring which may cause physical injury if not handled and disposed of carefully.

1.1 Intended use

Referring to the Installation and Maintenance Instructions, name-plate and Technical Information Sheet, check that the product is suitable for the intended use/application. This product complies with the requirements of the European Pressure Equipment Directive 2014/68/EU and all falls within category 'SEP'.

It should be noted that products within this category are required by the Directive not to carry the  mark.

- i) This product has been specifically designed for use on steam, air or condensate/water, which is in Group 2 of the above mentioned Pressure Equipment Directive. The products' use on other fluids may be possible but, if this is contemplated, Spirax Sarco should be contacted to confirm the suitability of the product for the application being considered.
- ii) Check material suitability, pressure and temperature and their maximum and minimum values. If the maximum operating limits of the product are lower than those of the system in which it is being fitted, or if malfunction of the product could result in a dangerous overpressure or overtemperature occurrence, ensure a safety device is included in the system to prevent such over-limit situations.
- iii) Determine the correct installation situation and direction of fluid flow.
- iv) Spirax Sarco products are not intended to withstand external stresses that may be induced by any system to which they are fitted. It is the responsibility of the installer to consider these stresses and take adequate precautions to minimise them.
- v) Remove protection covers from all connections and protective film from all name-plates, where appropriate, before installation on steam or other high temperature applications.

1.2 Access

Ensure safe access and if necessary a safe working platform (suitably guarded) before attempting to work on the product. Arrange suitable lifting gear if required.

1.3 Lighting

Ensure adequate lighting, particularly where detailed or intricate work is required.

1.4 Hazardous liquids or gases in the pipeline

Consider what is in the pipeline or what may have been in the pipeline at some previous time. Consider: flammable materials, substances hazardous to health, extremes of temperature.

1.5 Hazardous environment around the product

Consider: explosion risk areas, lack of oxygen (e.g. tanks, pits), dangerous gases, extremes of temperature, hot surfaces, fire hazard (e.g. during welding), excessive noise, moving machinery.

1.6 The system

Consider the effect on the complete system of the work proposed. Will any proposed action (e.g. closing isolation valves, electrical isolation) put any other part of the system or any personnel at risk? Dangers might include isolation of vents or protective devices or the rendering ineffective of controls or alarms. Ensure isolation valves are turned on and off in a gradual way to avoid system shocks.

1.7 Pressure systems

Ensure that any pressure is isolated and safely vented to atmospheric pressure. Consider double isolation (double block and bleed) and the locking or labelling of closed valves. Do not assume that the system has depressurised even when the pressure gauge indicates zero.

1.8 Temperature

Allow time for temperature to normalise after isolation to avoid danger of burns.

1.9 Tools and consumables

Before starting work ensure that you have suitable tools and/or consumables available. Use only genuine Spirax Sarco replacement parts.

1.10 Protective clothing

Consider whether you and/or others in the vicinity require any protective clothing to protect against the hazards of, for example, chemicals, high/low temperature, radiation, noise, falling objects, and dangers to eyes and face.

1.11 Permits to work

All work must be carried out or be supervised by a suitably competent person.

Installation and operating personnel should be trained in the correct use of the product according to the Installation and Maintenance Instructions.

Where a formal 'permit to work' system is in force it must be complied with. Where there is no such system, it is recommended that a responsible person should know what work is going on and, where necessary, arrange to have an assistant whose primary responsibility is safety.

Post 'warning notices' if necessary.

1.12 Handling

Manual handling of large and/or heavy products may present a risk of injury.

Lifting, pushing, pulling, carrying or supporting a load by bodily force can cause injury particularly to the back. You are advised to assess the risks taking into account the task, the individual, the load and the working environment and use the appropriate handling method depending on the circumstances of the work being done.

1.13 Residual hazards

In normal use the external surface of the product may be very hot. If used at the maximum permitted operating conditions the surface temperature of some products may reach temperatures of 550 °C (1022 °F).

Many products are not self-draining. Take due care when dismantling or removing the product from an installation (refer to 'Maintenance instructions').

1.14 Freezing

Provision must be made to protect products which are not self-draining against frost damage in environments where they may be exposed to temperatures below freezing point.

1.15 Disposal

Unless otherwise stated in the Installation and Maintenance Instructions, this product is recyclable and no ecological hazard is anticipated with its disposal providing due care is taken.

Please visit the Spirax Sarco product compliance web pages

<https://www.spiraxsarco.com/product-compliance>

for up to date information on any substances of concern that may be contained within this product. Where no additional information is provided on the Spirax Sarco product compliance web page, this product may be safely recycled and/or disposed providing due care is taken. Always check your local recycling and disposal regulations.

1.16 Returning products

Customers and stockists are reminded that under EC Health, Safety and Environment Law, when returning products to Spirax Sarco they must provide information on any hazards and the precautions to be taken due to contamination residues or mechanical damage which may present a health, safety or environmental risk. This information must be provided in writing including Health and Safety data sheets relating to any substances identified as hazardous or potentially hazardous.

2. General product information

2.1 General description

The TD120M is a maintainable high pressure thermodynamic steam trap with integral strainer and replaceable seat to ease maintenance. It has low capacity specifically designed for superheated mains drainage applications up to 250 bar g (3625 psi g).

Standards

This product fully complies with the requirements of the European Pressure Equipment Directive 2014/68/EU.

Certification

This product is available with certification to EN 10204 3.1.

Note: All certification/inspection requirements must be stated at the time of order placement.

Note: For additional information see Technical Information Sheet TI-P150-11.

2.2 Sizes and pipe connections

½", ¾" and 1" Butt weld ends to suit Schedule 160 pipe.

½", ¾" and 1" Socket weld ends to ASME (ANSI) B 16.11 Class 6000.

DN15 and DN25 standard integral flange EN 1092 PN160 and PN250.

DN15, DN20 and DN25 standard integral flanges: ASME (ANSI) Class 600, 900 and 1500, and EN 1092 PN100.

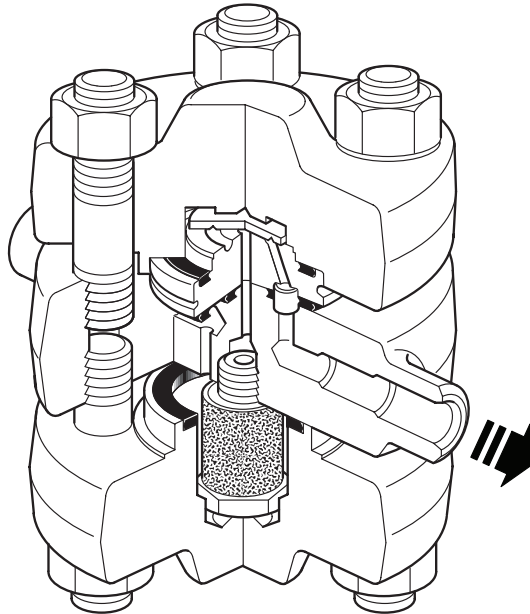
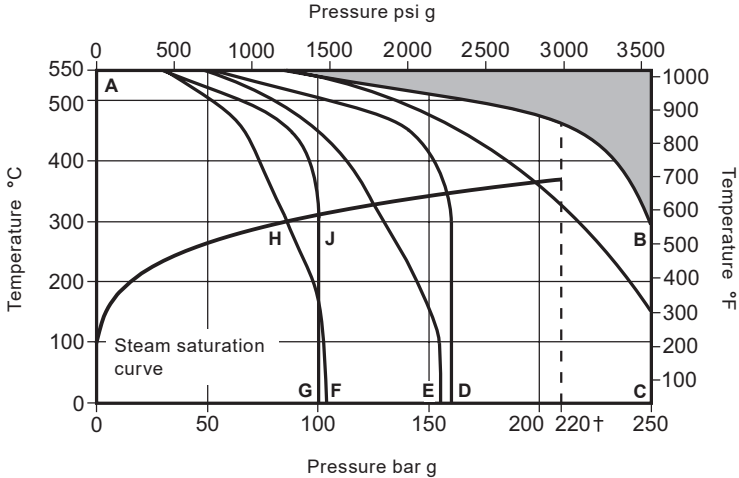

Fig. 1 TD120M with butt weld connections

TD120M Thermodynamic Steam Trap with Replaceable Seat

2.3 Pressure/temperature limits (ISO 6552)



Note:
If the product is used at pressures above 170 bar g we would recommend regular inspection of the seat.

The product **must not** be used in this region.

- A - B** Flanged to EN 1092 PN250, socket weld and butt weld ends.
- A - C** Flanged to ASME (ANSI) Class 1500.
- A - D** Flanged to EN 1092 PN160
- A - E** Flanged to ASME (ANSI) Class 900.
- A-H-F** Flanged to ASME (ANSI) Class 600.
- A-J-G** Flanged to EN 1092 PN100.

Body design conditions		PN250	
PMA	Maximum allowable pressure	250 bar g @ 300 °C	(3625 psi g @ 572 °F)
TMA	Maximum allowable temperature	550 °C @ 80 bar g	(1022 °F @ 1160 psi g)
	Minimum allowable temperature	-29 °C	(-20 °F)
PMO †	Maximum operating pressure for saturated steam service	220 bar g @ 374 °C	(3190 psi g @ 705 °F)
TMO	Maximum operating temperature	550 °C @ 80 bar g	(1022 °F @ 1160 psi g)
	Minimum operating temperature	0 °C	(32 °F)
Note: For lower operating temperatures consult Spirax Sarco.			
PMOB	Maximum operating backpressure should not exceed 50% of the upstream pressure		
	Minimum operating differential pressure	8 bar g	(116 psi g)
	Designed for a maximum cold hydraulic test pressure of	375 bar g	(5437 psi g)

TD120M Thermodynamic Steam Trap with Replaceable Seat

3. Installation

Note: Before actioning any installation observe the 'Safety information' in Section 1.

Referring to the Installation and Maintenance Instructions, name-plate and Technical Information Sheet, check that the product is suitable for the intended installation:

- 3.1** Check materials, pressure and temperature and their maximum values. If the maximum operating limit of the product is lower than that of the system in which it is being fitted, ensure that a safety device is included in the system to prevent overpressurisation.
- 3.2** Determine the correct installation situation and the direction of fluid flow. A typical installation is shown in Figure 2.
- 3.3** Remove protective covers from all connections and protective film from all name-plates, where appropriate, before installation on steam or other high temperature applications.
- 3.4** The preferred installation is in a horizontal pipe with the name-plate uppermost. The trap will operate in other positions, but the service life may be affected! The installation should have a small drop leg preceding the trap. Access for removal of the integral strainer screen should also be provided.
- 3.5** Suitable isolation valves must be installed to allow for safe maintenance and trap replacement. Where the trap discharges into a closed return system a non-return valve should be fitted downstream to prevent flow.
- 3.6** Always open isolation valves slowly until normal operating conditions are achieved - this will avoid system shocks. Check for leaks and correct operation.
- 3.7** Always ensure the correct tools, safety procedures and protective equipment are used at all times.
- 3.8** The disc and seating surfaces of these traps have been produced to a high degree of flatness to achieve good shut-off under high pressure conditions. An integral strainer helps prevent dirt and scale from entering the trap. If particles become entrapped between the disc and seat, the high flow velocities can cause rapid wear and erosion. A separate strainer and/or dirt pocket will provide additional protection.
- 3.9** When a socket weld or butt weld trap is being installed the welding should be carried out to an approved procedure of a recognised standard.

Note: If the trap is to discharge to atmosphere ensure it is to a safe place, the discharging fluid may be at a temperature of 100 °C (212 °F).

4. Commissioning

4.1 Commissioning with particular reference to venting air

Initial start-up can take several hours (or days) to bring the system to normal operating pressure and temperature. Even if the trap has replaced another trap while the main system has remained running, it may still be necessary to vent air from the drop leg.

If the trap is some distance from stop valve 'A' (Figure 2), it could be possible to air lock the pipework between valve 'A' and the trap (i.e. the trap closes to air and does not readily allow steam to enter the pipework).



To overcome this on start-up the following procedure should be adopted. With the stop valve 'B' closed, drain valve 'C' open, slowly and partially open stop valve 'A'. This will discharge the air, condensate and any pipe debris.

Valve 'C' should then be fully closed, and valves 'A' and 'B' slowly opened to the fully open position. When the trap is more than 2 m (6 ft) away from the vertical drain leg, a suitable drop leg at the inlet to the trap can improve its service life by ensuring that the trap does not see a mixture of steam and condensate.

Important note

After the trap has been in service at normal operating pressure and temperature for 24 hours, it is essential that the cover nuts be retightened (see Table 1). This will ensure the correct compression of the gasket under service conditions.

Table 1 Recommended tightening torques

Item	Part	 or  mm	N m	(lbf ft)
4	Stud	22 A/F	25 - 35	(18 - 26)
8	Nut	M16	85 - 90	(62.5 - 66)
9		23 A/F M16	160 - 180	(118 - 132)

5. Operation

The TD120M is a thermodynamic steam trap which uses a disc to control the release of condensate and to trap steam. The trap cycles open and closed to discharge condensate, close to steam temperature, and closes tight between discharges.

The disc, which is the only moving part, rises and falls in response to dynamic forces produced by the partial re-evaporation (flashing) of hot condensate. Cool condensate, air and other non-condensable gases enters the trap through the central orifice, lifts the disc, and discharges through the outlet orifice. When the condensate approaches steam temperature, a portion of it flashes as it enters the trap. The flash steam passes at high velocity over the underside of the disc and collects in the control chamber above. The resulting pressure imbalance, forces the disc downward onto the seating surfaces, stopping the flow. The trap remains tightly closed until the loss of heat through the trap body lowers the control chamber pressure, allowing the inlet pressure to raise the disc and repeat the cycle.

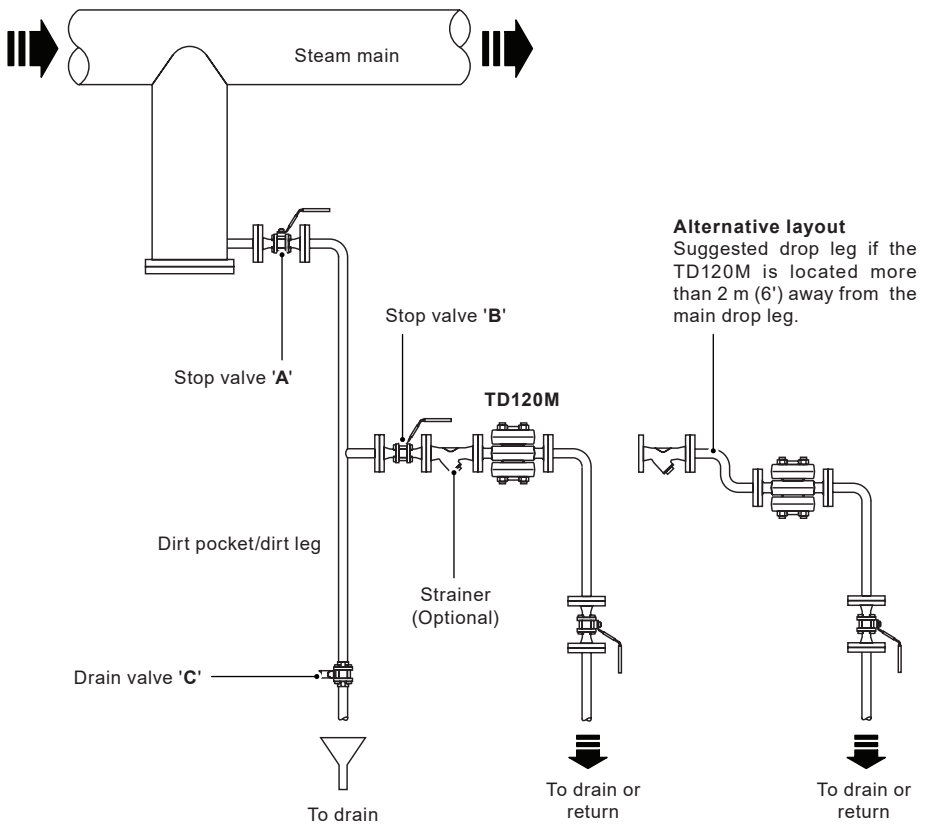

Fig. 2 Typical installation

TD120M Thermodynamic Steam Trap with Replaceable Seat

6. Maintenance

Note: Before actioning any maintenance programme observe the 'Safety information' in Section 1.



Warning

The cover gasket contains a thin stainless steel support ring which may cause physical injury if not handled and disposed of carefully.

6.1 How to fit the disc and seat:

- Remove the top cover (3) by unscrewing the four nuts (9) that are securing it in place.
- Lift off the disc (2).
- Lift out the seat (6). The use of 2 screwdrivers inserted into the groove may ease removal. Ensure that the location ferrule (12) is also removed.
- Carefully remove the seat gaskets (10 and 7) from the body of the trap. Ensure that no damage is caused to the trap body.
- Ensure that the gasket contact surface in the body is clean and fit new seat gaskets (10 and 7).
- Fit the new seat (6) ensuring that the location ferrule (12) is firmly located in the body.
- Fit the new seat gasket (7) making sure that the gasket faces are perfectly clean and fit a new disc (2). Ensure that the disc is fitted with the grooves facing the seat.
- Reassemble the top cover (3).
- Ensure that the name-plate is placed over the studs prior to reassembling the four nuts (9).
- Retighten the cover nuts (9) to the recommended tightening torques (see Table 1).
- After 24 hours in service, and when reassembling, the nuts should be tightened in a diagonally opposite sequence.
- Open the isolation valves slowly until normal operating conditions are achieved.
- Check for leaks.

Table 1 Recommended tightening torques

Item	Part	 or mm 	N m	(lbf ft)
4	Stud	22 A/F	25 - 35	(18 - 26)
8	Nut	M16	85 - 90	(62.5 - 66)
9		23 A/F M16	160 - 180	(118 - 132)

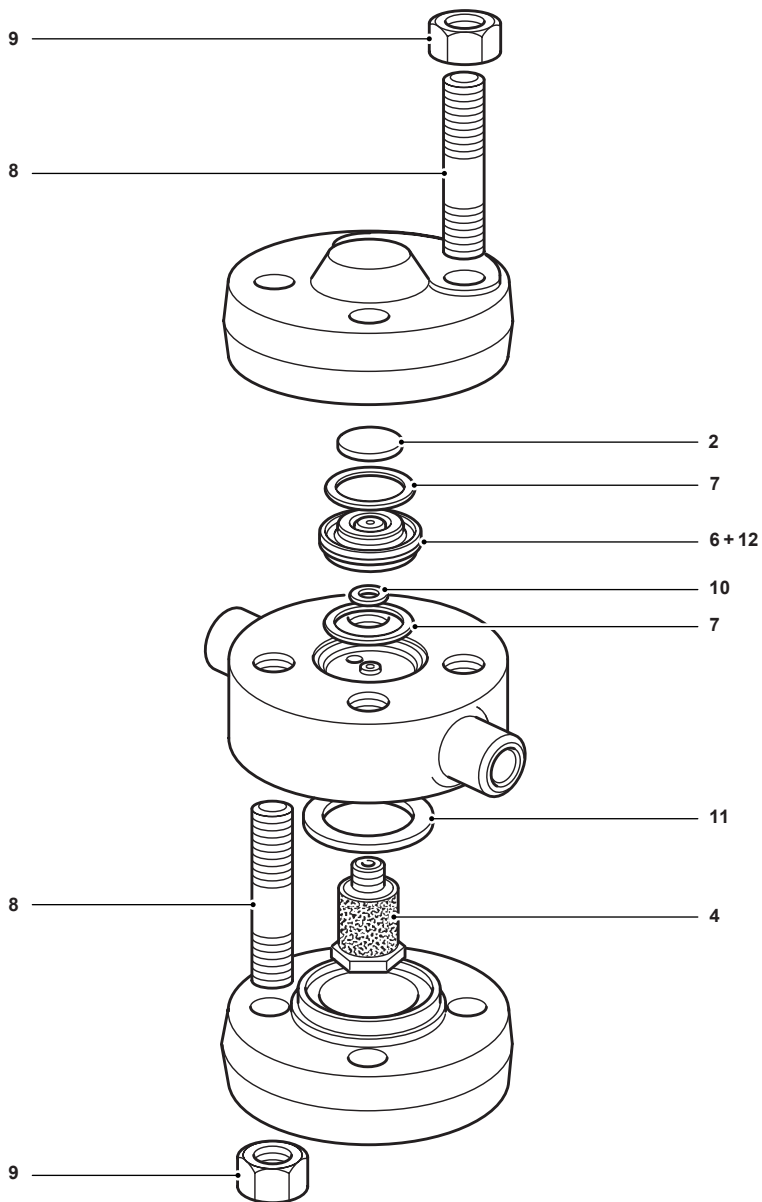

Fig. 3a TD120M with butt weld connections



6.2 How to clean or replace the strainer:

- Access to the strainer screen can be obtained by removing the bottom cover (5) by unscrewing the four nuts (9) that are securing it in place.
- Remove the strainer screen (4).
- Fit the new or cleaned strainer screen into the recess on the underside of the cover.
- A new gasket (11) should be fitted and the cover refitted.
- Retighten the cover nuts (9) to the recommended tightening torques (see Table 1).
- After 24 hours in service, and when reassembling, the nuts should be tightened in a diagonally opposite sequence.
- Open the isolation valves slowly until normal operating conditions are achieved.
- Check for leaks.
- It is recommended that the strainer screen be inspected as part of a scheduled maintenance programme.

6.3 To replace the cover studs:

- After removing the old cover studs, fit new cover studs until the studs bottom out. The use of a thread lubricant is recommended.

Table 1 Recommended tightening torques

Item	Part	 or mm		N m	(lbf ft)
4	Stud	22 A/F		25 - 35	(18 - 26)
8	Nut		M16	85 - 90	(62.5 - 66)
9		23 A/F	M16	160 - 180	(118 - 132)

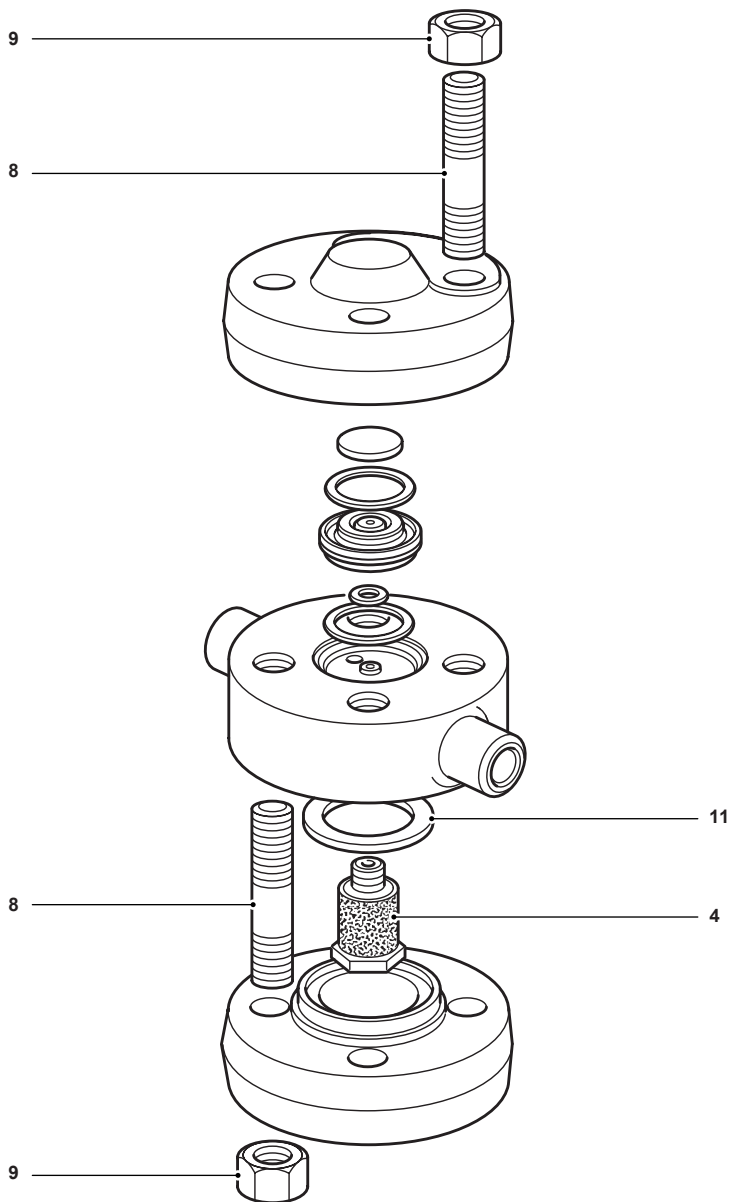

Fig. 3b TD120M with butt weld connections

TD120M Thermodynamic Steam Trap with Replaceable Seat

7. Spare parts

The spare parts available are shown in solid outline. Parts drawn in broken line are not supplied as spares.

Available spares

Set of cover studs and nuts	8 (8 off), 9 (8 off)
Strainer screen and gasket	4, 11
Set of gaskets	7 (2 off), 10, 11
Maintenance kit	2, 4, 7 (2 off), 10, 11, 6+12

How to order spares

Always order spares by using the description given in the column headed 'Available spares' and state the size and type of trap.

Example: 1 - Seat and disc assembly for a Spirax Sarco DN15 TD120M high pressure thermodynamic steam trap.

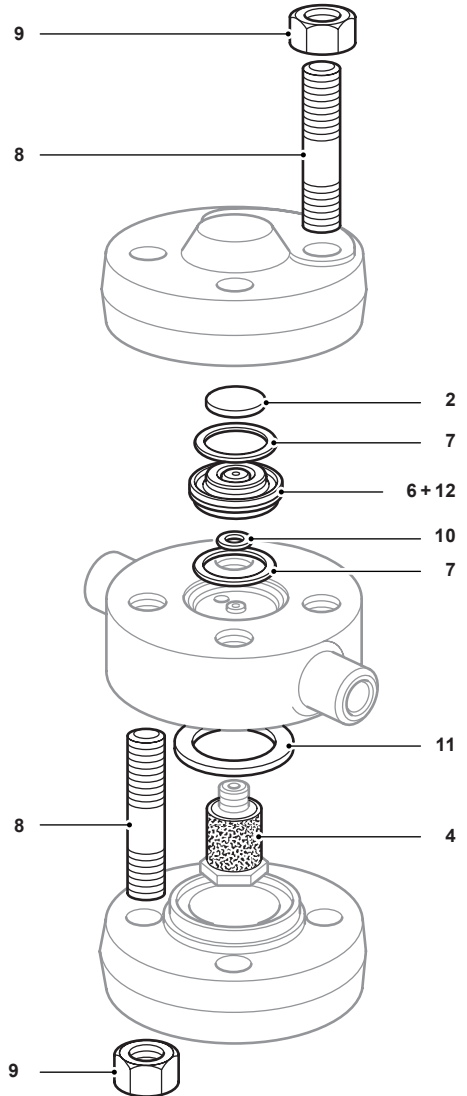

Fig. 4

